



PicoBlaze for Spartan-6, Virtex-6 and 7-Series (KCPSM6)

Including Ultra-Compact UART Macros and Reference Designs

Ken Chapman

30th September 2013

Release: 7

Disclaimer

Notice of Disclaimer

Xilinx is disclosing this Application Note to you “**AS-IS**” with no warranty of any kind. This Application Note is one possible implementation of this feature, application, or standard, and is subject to change without further notice from Xilinx. You are responsible for obtaining any rights you may require in connection with your use or implementation of this Application Note. XILINX MAKES NO REPRESENTATIONS OR WARRANTIES, WHETHER EXPRESS OR IMPLIED, STATUTORY OR OTHERWISE, INCLUDING, WITHOUT LIMITATION, IMPLIED WARRANTIES OF MERCHANTABILITY, NONINFRINGEMENT, OR FITNESS FOR A PARTICULAR PURPOSE. IN NO EVENT WILL XILINX BE LIABLE FOR ANY LOSS OF DATA, LOST PROFITS, OR FOR ANY SPECIAL, INCIDENTAL, CONSEQUENTIAL, OR INDIRECT DAMAGES ARISING FROM YOUR USE OF THIS APPLICATION NOTE.

Copyright © 2010-2013, Xilinx, Inc.

This file contains proprietary information of Xilinx, Inc. and is protected under U.S. and international copyright and other intellectual property laws.

Contents

- 4 – Acknowledgements
- 5 – Welcome!
- 6 – **KCPSM6 Architecture and Features**

The KCPSM6 Design Flow

- 8 – Components and Connections
- 9 – Inserting KCPSM6 into HDL
- 11 – Program Memory
- 12 – Inserting Program Memory into HDL
- 13 – PSM files and Assembler
- 15 – Adding Files to ISE Project
- 16 – I/O Ports
- 17 – Defining Output Ports
- 18 – CONSTANT Directives
- 19 – Defining Input Ports
- 21 – Your first Program
- 23 – Formatted PSM file (.fmt)
- 24 – Configuration
- 25 – JTAG Loader
- 30 – That's It!

Hardware Reference

- 32 – Pin Descriptions
- 34 – KCPSM6 Generics
- 35 – Reset operation and waveforms
- 37 – Sleep control and waveforms
- 40 – Interrupts
- 42 – Interrupt vector and ADDRESS directive
- 43 – Interrupt circuits
- 44 – Interrupt waveforms
- 45 – HDL Simulation Features
- 47 – Production Program Memory (ROM_form)

Software Reference

- 49 – Assembler
- 51 – Log File (.log)
- 52 – PSM Syntax
- 53 – Registers and NAMEREG

- 54 – **KCPSM6 Instruction Set**
- 55 – LOAD
- 56 – AND
- 57 – OR
- 58 – XOR
- 59 – ADD
- 60 – ADDCY
- 61 – SUB
- 62 – SUBCY
- 63 – TEST
- 64 – TESTCY
- 65 – COMPARE
- 66 – COMPARECY
- 67 – SL0 / SL1 / SLX / SLA
- 68 – SR0 / SR1 / SRX / SRA
- 69 – RL / RR
- 70 – REGBANK
- 71 – STAR
- 72 – General Purpose I/O Ports
(plus performance figures)
- 73 – INPUT
- 74 – OUTPUT
- 75 – Constant-Optimised Ports
- 78 – OUTPUTK
- 79 – Hybrid Output Ports
- 80 – Hybrid Ports and STRING Directive

- 81 – STORE
- 82 – FETCH
- 83 – ENABLE / DISABLE INTERRUPT
- 84 – RETURNI ENABLE /DISABLE
- 86 – Interrupts and Register Banks
- 87 – JUMP
- 88 – JUMP cc
- 89 – JUMP@
- 90 – Subroutines
- 92 – CALL
- 93 – CALL cc
- 94 – CALL@
- 96 – RETURN
- 97 – RETURN cc
- 98 – LOAD&RETURN
- 99 – LOAD&RETURN and STRING Directive
- 100 – TABLE Directive for Data and Sequences
- 101 – HWBUILD

Notes for KCPSM3 Users

- 102 – Hardware differences
- 103 – Assembler and software considerations
- 104 – ADDCY / SUBCY and the Z flag.

Reliability

- 106 – KCPSM6 Reliability
- 114 – Error Detection for Very High Reliability Designs.

Acknowledgments

Thank you to everyone that has used PicoBlaze over the years and for all the feedback you have provided. It is clear that having a processor that is very small and simple to use is important and valuable and hopefully you will agree that KCPSM6 continues the tradition. Your feedback has influenced the expansions and inclusion of new features but even the most commonly requested features are secondary to being small and easy to use so please don't be too disappointed if your ideal feature didn't make it this time. We are really looking forward to hearing your feedback on KCPSM6.

Thank you to Nick Sawyer for all the design reviews, ideas and discussions over the past 18 years of PicoBlaze.

Thank you to Kris Chaplin for JTAG Loader; you have saved every user days of our lives and truly made PicoBlaze easy to use and now you have made it even easier. Thank you to Srinivasa Attili and Ahsan Raza for adding the Digilent capability to this invaluable tool.

Finally, a special thank you to all of those PicoBlaze users that share their experiences and knowledge with others. The professors that teach so many students, the course instructors, those that provide helpful answers on the PicoBlaze forum, the amazing people that develop additional development tools for PicoBlaze, those that inspire others by showing what they did with PicoBlaze in a technical paper (or even on YouTube). To all of you, a huge thank you.

Welcome to KCPSM6

Welcome to the KCPSM6; the PicoBlaze optimised for use in Spartan-6, Virtex-6 and 7-Series devices. PicoBlaze has been very popular for more than 10 years and it continues to be used and adopted by thousands of engineers around the world. So either you are new to PicoBlaze or one of its existing users....

I'm new to PicoBlaze....

Why use KCPSM6?

KCPSM6 is a soft macro which defines an 8-bit micro controller which can be included one or more times in any Spartan-6, Virtex-6 or 7-Series design. Probably its greatest strengths are that it is 100% embedded and requires only 26 logic Slices and a Block Memory which equates to 4.3% of the smallest XC6SLX4 and just 0.11% of the XC6SLX150T. This combination means that you can decide when and where to insert KCPSM6 in your design as it develops rather than requiring any pre-planning. Insertion only requires the most fundamental HDL coding and design techniques making it a simple task for any competent hardware engineer and nothing too challenging for a novice. PicoBlaze has been used in many student projects so just follow the steps and examples and you will have it working before lunch time.

But why embed a small processor in an FPGA design?

In simple terms, hardware is parallel and processors are sequential. So converting a small amount of hardware into a processor is often a more efficient way to implement sequential functions such as state machines (especially complex ones) or to time-share hardware resources when there are several slower tasks to be performed. It is also more natural to describe sequential tasks in software whereas HDL is best at describing parallel hardware. Don't worry about this theory; it will just make sense when you start using KCPSM6 and see for yourself what it can do well (and can't do).

Please carefully follow pages 6 to 30. It sounds a lot but it is a step by step guide and it shouldn't take long to get your first KCPSM6 running. The rest of this document is for reference including examples, suggestions and more advanced techniques which you can look at more later. Most of all, have fun!

I've used PicoBlaze before....

What is KCPSM6?

The most important thing is that KCPSM6 will look very familiar to you. There are some minor changes to the hardware ports associated with enhancements but it is a drop in replacement for KCPSM3 in most respects. Likewise, the instruction set has expanded but you should be able to assemble KCPSM3 code to begin with and have it running in your first KCPSM6 design before looking at what you can now do better.

KCPSM6 is ~~bigger~~ smaller and better!

The architectural differences between Generation-3 and Generation-6 and later devices does not make comparison of size obvious, but at only 26 Slices, KCPSM6 really is 25% smaller in real terms. This equates to 4.3% of the smallest XC6SLX4 and just 0.11% of the XC6SLX150T so how many will you be putting in your next design? By the way, the current record stands at 3,602 in an XC7V2000T and it wasn't full ☺.

KCPSM6 has quite a few additional features for you to discover but the principle enhancements are support for programs up to 4K instructions, an additional bank of 16 registers, dynamic JUMP and CALL, user defined interrupt vector and constant-optimised output ports.

A special section called 'Notes for KCPSM3 Users' is provided starting on page 102 and you are advised to start with pages 102 and 103 which will refer you to the relevant sections in the main document. Alternatively, have a quick look through the following pages (6 to 29) where you should quickly notice the differences amongst all that seems to be familiar! Of course you could just dive in and start playing ☺

KCPSM6 Architecture and Features

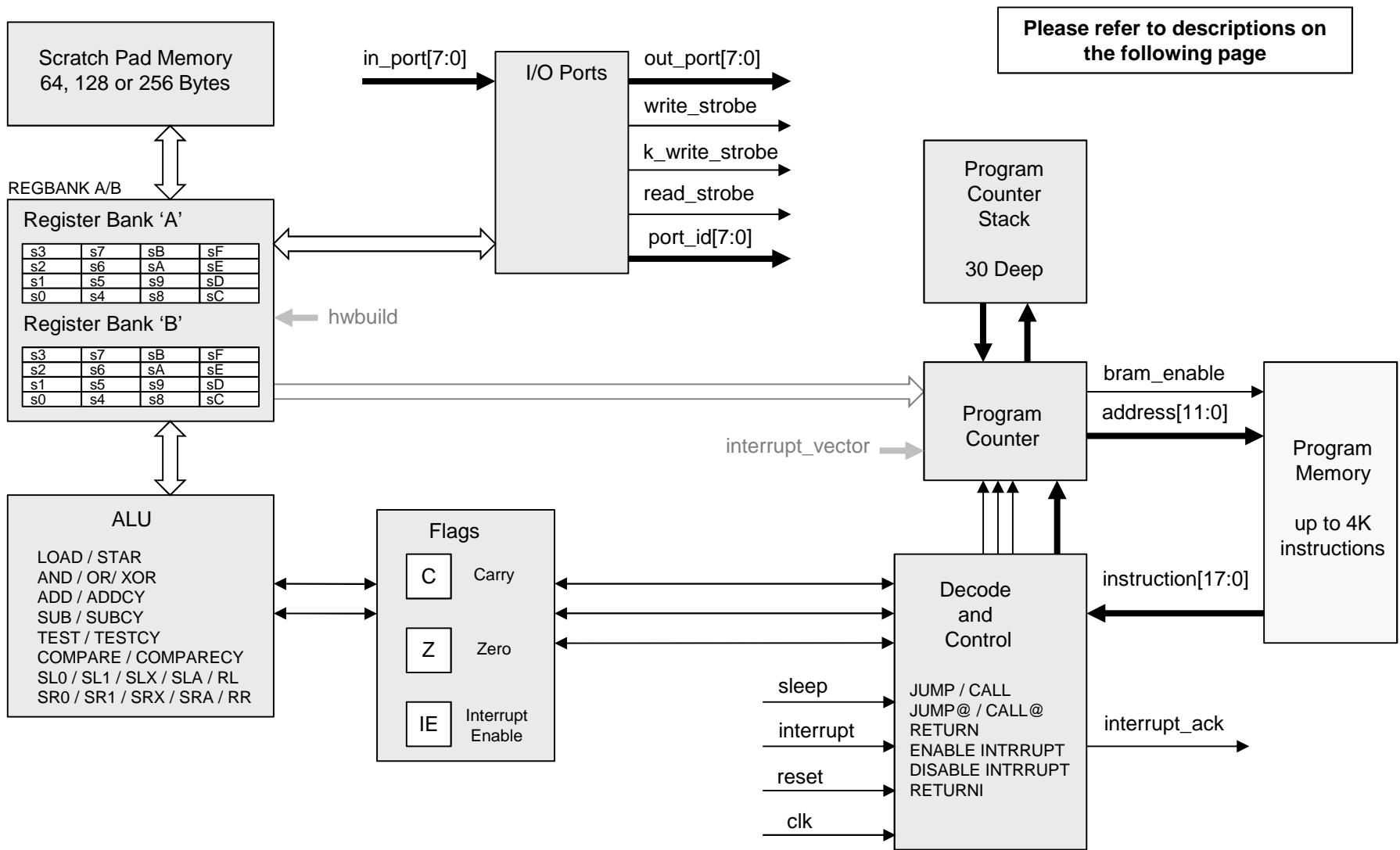

KCPSM6 Architecture and Features

KCPSM6 is an 8-bit data processor that can execute a program of up to 4K instructions. All instructions are defined by a single 18-bit instruction and all instructions execute in 2 clock cycles. The maximum clock frequency is device and design dependant but up to 105MHz can be achieved in a Spartan-6 (-2 speed grade) and up to 238MHz can be achieved in a Kintex-7 (-3 speed grade) device. This means that the execution performance of KCPSM6 can be in the range 52 to 119 million instructions per second (52 to 119 MIPS) which is many times faster than achieved by small commercial 8-bit processors. Page 72 shows the circuit that was used to evaluate performance and provides figures for more devices and speed grades. Whilst performance is not the most important reason for using KCPSM6 in a design, it is the ability to operate at the same clock frequency as the hardware it interacts which makes it so straightforward to embed in your design. The combination of total predictability and relatively high performance also makes KCPSM6 capable of implementing many functions traditionally considered to be the domain of pure hardware.

KCPSM6 provides 2 banks of 16 general purpose registers which are central to the flow and manipulation of all 8-bit data. In a typical application information is read from input ports into registers, the contents of the registers are manipulated and interrogated using the Arithmetic Logical Unit (ALU), and the resulting values contained in the registers are written to the output ports. All operations can be performed using any register (i.e. there are no special purpose registers) so you have complete freedom to allocate and use registers when writing your programs.

The 16 registers provided in bank 'A' (the default bank) are adequate to implement most individual tasks. However, when moving from one task to another (e.g. when calling a subroutine) or handling larger data sets the scratch pad memory provides 64-bytes (default), 128-byte or 256-bytes of random access storage. Once again there is complete freedom to transfer information between any register in the active bank and any location of scratch pad memory. A second completely independent set of 16 registers are provided in bank 'B' and are of most value when it is desirable to switch rapidly between tasks that are generally unrelated. The most compelling example is when servicing an interrupt which is a rather more advanced technique to be covered later!

The ALU implements a comprehensive set of instructions including bitwise logical AND, OR and XOR, arithmetic ADD and SUBtract, a set of shift and rotate left/right, TEST including parity calculation and COMPARE. All operations are performed using contents of registers and/or constant values contained in the instruction word. As well as results being returned to registers there are two flags; zero (Z) and carry (C) whose states reflect the outcome of the operation. These flags can be used to influence the flow of the program execution or to cascade 8-bit operations to implement operations on data of 16, 24, 32-bits or more.

The program counter is used to fetch each instruction from the program memory. A program always starts at address zero and under normal conditions executes sequentially with the program counter incrementing every 2 clock cycles. 'JUMP' instructions can be used to deviate from this natural flow to implement loops and branches within the program. These jumps can also be made conditionally based on the states of the flags (e.g. jump if the result was zero 'JUMP Z, aaa') allowing different program execution depending on the circumstances. A fully automatic program counter stack enables the nesting of up to 30 subroutines (including an interrupt service routine) to be performed in response to conditional and unconditional CALL and RETURN instructions.

KCPSM6 can be reset, supports one mask-able interrupt with acknowledge, and a 'sleep' control can be used to suspend program execution for any period of time to save power, wait under hardware control (e.g. Handshaking) or to enforce slower execution rate relative to the clock frequency.

KCPSM6 Components and Connections

To insert KCPSM6 into a design there are only two files defining two components. Not surprisingly 'kcpsm6' defines the actual processor and its ports. It also has three generic values but they have been assigned default values which can be used until you have any reason to change them. The second component defines the memory that will contain your program once it has been written and assembled. It also has three generic values which do need to be set appropriately. Please take a moment to familiarise yourself with the components and the general arrangement for the connection of the program memory to the processor. The following pages will show you the details of how to insert this in your HDL design.

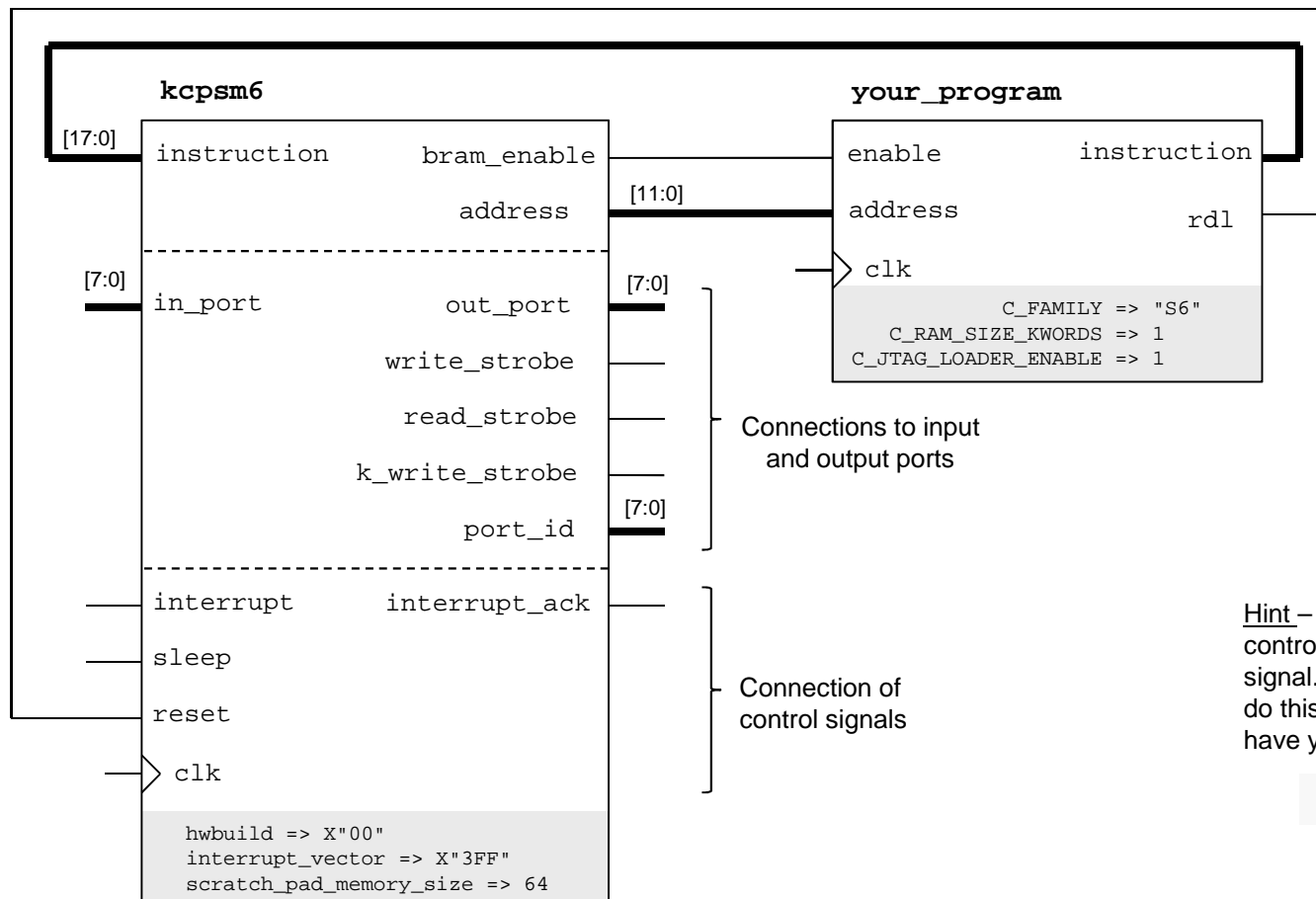

KCPSM6 supports programs up to 4K instructions the address is 12-bits. To keep your design as simple as possible and to maintain flexibility the full 12-bit address is always connected even when the program size is smaller.

The 'bram_enable' signal is used to achieve the lowest power consumption.

The program memory has the option to include the JTAG Loader utility which facilitates rapid development of your KCPSM6 program. 'rdl' is a 'reset during load' signal associated with the loader and needs to be connected to the reset on the processor.

Hint – If you want to include your own reset control in your design then OR it with the 'rdl' signal. However it is recommended that you only do this once you are familiar with KCPSM6 and have your first design working.

```
kcpsm6_reset <= cpu_rst or rdl;
```

Inserting KCPSM6 into Your Design

Please note that the Verilog equivalent of each file is also provided.

KCPSM6 is included in your design in exactly the same way as any hardware component. This document is not intended to teach you HDL coding or how to use the Xilinx ISE tools to implement a complete Spartan-6, Virtex-6 or 7-Series design but it will remind you of the steps that need to be taken and provide you with everything you need that is specific to KCPSM6.

Inserting the actual KCPSM6 component into your design is easy especially if you adopt the recommended signal names as shown below.

Hint – This is not supposed to be an exercise in typing so the file called 'kcpsm6_design_template.vhd' is provided and contains all these pieces of code for you to simply copy and paste into the appropriate places in your own design.

```
component kcpsm6
  generic(
    hwbuild : std_logic_vector(7 downto 0) := X"00";
    interrupt_vector : std_logic_vector(11 downto 0) := X"3FF";
    scratch_pad_memory_size : integer := 64);
  port (
    address : out std_logic_vector(11 downto 0);
    instruction : in std_logic_vector(17 downto 0);
    bram_enable : out std_logic;
    in_port : in std_logic_vector(7 downto 0);
    out_port : out std_logic_vector(7 downto 0);
    port_id : out std_logic_vector(7 downto 0);
    write_strobe : out std_logic;
    k_write_strobe : out std_logic;
    read_strobe : out std_logic;
    interrupt : in std_logic;
    interrupt_ack : out std_logic;
    sleep : in std_logic;
    reset : in std_logic;
    clk : in std_logic);
end component;
```

In order that you can instantiate KCPSM6 in the design section of your design file (shown on the next page) it is necessary to define the signals to connect to each of the ports. The recommended signal names are shown here and can also be pasted into your design file (after 'architecture' and before 'begin' in VHDL). Of course you can modify the signal names if you wish and you would need to if you had more than one KCPSM6 instance in the same design file but neither is recommended until you have more experience.

Paste the KCPSM6 component declaration into the appropriate section of your design file (i.e. after 'architecture' and before 'begin' in VHDL).

The generics can be left with the default values as shown as it is the component instantiation that will actually define them.

```
signal address : std_logic_vector(11 downto 0);
signal instruction : std_logic_vector(17 downto 0);
signal bram_enable : std_logic;
signal in_port : std_logic_vector(7 downto 0);
signal out_port : std_logic_vector(7 downto 0);
Signal port_id : std_logic_vector(7 downto 0);
Signal write_strobe : std_logic;
Signal k_write_strobe : std_logic;
Signal read_strobe : std_logic;
Signal interrupt : std_logic;
Signal interrupt_ack : std_logic;
Signal kcpsm6_sleep : std_logic;
Signal kcpsm6_reset : std_logic;
```

Inserting KCPSM6 into Your Design

Please note that the Verilog equivalent of each file is also provided.

Paste the instantiation of KCPSM6 into your design. If this is your first design then there is very little to do except copy and paste from the reference file and specify your clock. Even advanced users will only have minor adjustments to make but they are covered later in this document (page 101).

```
processor: kcpsm6
  generic map (
    hwbuild => X"00",
    interrupt_vector => X"3FF",
    scratch_pad_memory_size => 64)
  port map(
    address => address,
    instruction => instruction,
    bram_enable => bram_enable,
    port_id => port_id,
    write_strobe => write_strobe,
    k_write_strobe => k_write_strobe,
    out_port => out_port,
    read_strobe => read_strobe,
    in_port => in_port,
    interrupt => interrupt,
    interrupt_ack => interrupt_ack,
    sleep => kcpsm6_sleep,
    reset => kcpsm6_reset,
    clk => clk );
```

The values assigned to the three generics can remain set to the default values as shown. Their purpose is described in detail later in this document and they only need to be changed if and when you want to use the features they are associated with.

If you used the default signal names then nothing needs to be modified. Otherwise connect the signals you have defined to these ports.

You will need to specify the clock signal that is available in your design. As a guide anything up to 105MHz in a Spartan-6 (-2) and up to 240MHz in Virtex-6 or 7-Series (-3) is suitable and as with all general clocks it should be distributed via a clock buffer (typically inserted automatically by the synthesis tools).

```
kcpsm6_sleep <= '0';
interrupt <= '0';
```

If this is your first KCPSM6 design or you have no intention of using interrupts or the sleep function then these signals should be tied to '0'.

```
sleep => '0',
```

```
interrupt => '0',
```

Alternatively these KCPSM6 inputs can be tied directly to '0' in the port map. This avoids the requirement for these signals to be defined but if you decide to make use of either of these features as your design develops it will just result in more modifications so it is not the recommended technique.

Program Memory

KCPSM6 Programs are stored in Block Memory (BRAM). The number of BRAMs required depends on the target device as well as the size of the program. Due to the flexibility of BRAM and FPGA devices it would be possible to implement a memory of any size up to the maximum of 4K instructions supported by KCPSM6. However the most natural and commonly used program sizes are shown in the table below showing how many BRAMs are required.

Programs Size (instructions)	Spartan-6	Vitex-6, Artix-7, Kintex-7, Virtex-7
0.125K / 0.25K	○ 9 / 18 Slices	○ 9 / 18 Slices
1K	● 1 BRAM	○ ½ BRAM
2K	○ 2 BRAMs	● 1 BRAM
4K	○ 4 BRAMs	○ 2 BRAM

● The most natural program size implemented by the 18k-bit BRAMs in Spartan-6 is 1K instructions and the 36k-bit BRAM of Virtex-6 is ideally suited to programs of up to 2K instructions.

These are the recommended sizes when setting up KCPSM6 initially.

○ These sizes are also supported by the files provided and fit well in the devices when required.

Hint – A program of up to 128 or 256 instructions can be implemented in just 9 or 18 Slices and this can be a useful technique when there is a high demand for block memory within a design (see page 47 for details). Even with such small programs, KCPSM6 can implement a complex state machine in ~40 Slices. However, it is strongly recommended that a program is always developed using block memory first as JTAG Loader can then be used.

○ Whilst a 4K memory is supported in a Spartan-6 is not such a natural fit and will result in a lower maximum clock frequency (i.e. Be aware of this when operating closer to device limits).

Due to the errata described in EN148 there are no plans to support a 0.5K memory using a 9K BRAM in Spartan-6.

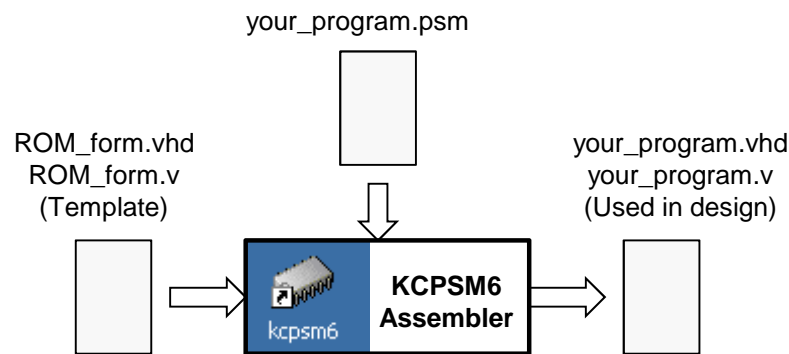

Program Memory Definition

To be completely compatible with the normal hardware design flow the program memory is defined by a standard HDL file which you include in your design in the same way as any other component (see next page). This file is generated by the KCPSM6 assembler and you will see how to do that later but the basic principle is as follows....

The KCPSM6 assembler reads and assembles your program (PSM file) into the instruction codes. It then reads an HDL template file called 'ROM_form.vhd' (or ROM_form.v) into which it inserts your assembled program and writes out the HDL file defining the program memory containing your program for use in your design.

Inserting a Program Memory into Your Design

Please note that the Verilog equivalent of each file is also provided.

During the development phase of your hardware design and KCPSM6 program it is highly recommended that you use the default 'ROM_form' template with the assembler such that the KCPSM6 assembler will generate a program definition file exactly as shown below. In this way you don't need to worry that you haven't written a program or run the assembler yet because we know the format of the program definition file that will be generated in advance and we can control everything by setting the generic values as shown below.

Hint – This is not supposed to be an exercise in typing so the file called 'kcpsm6_design_template.vhd' is provided and contains all these pieces of code for you to simply copy and paste into the appropriate places in your own design.

```
component your_program
  generic(
    C_FAMILY : string := "S6";
    C_RAM_SIZE_KEYWORDS : integer := 1;
    C_JTAG_LOADER_ENABLE : integer := 0);
  Port (
    address : in std_logic_vector(11 downto 0);
    instruction : out std_logic_vector(17 downto 0);
    enable : in std_logic;
    rdl : out std_logic;
    clk : in std_logic);
end component;
```

Paste the program memory component declaration into the appropriate section of your design file (i.e. after 'architecture' and before 'begin' in VHDL).

You **must** modify the name of the component so that you assign a unique name that will correspond with your KCPSM6 program.

The generics can be left with the default values as shown but you could modify them if you would prefer (e.g. if you are using a Virtex-6 it probably makes sense and looks better in your design if you change the default 'C_FAMILY' value to "V6").

Paste the instantiation of the program memory into your design. It normally makes sense to instantiate the program memory immediately after the instantiation of the KCPSM6 processor that it is attached to. Once again you **must** modify the name of the instantiated component to correspond with the name of your KCPSM6 program. Unless you wish to change the instance name ('program_rom' is used below) it can remain the same unless you are instantiating another program memory in the same design file.

```
program_rom: your_program
  generic map(
    C_FAMILY => "S6",
    C_RAM_SIZE_KEYWORDS => 1,
    C_JTAG_LOADER_ENABLE => 1)
  port map(
    address => address,
    instruction => instruction,
    enable => bram_enable,
    rdl => kcpsm6_reset,
    clk => clk);
```

Connect the appropriate signals to the ports. If you used the default signal names then nothing needs to be modified.

At this point the appropriate values must be assigned to each of the three generics. For a Spartan-6 design set 'C_FAMILY' to "S6" and it is recommended that you start with a program size of 1K by setting 'C_RAM_SIZE_KEYWORDS' to '1' as shown in this example.

For a Virtex-6 or 7-Series designs set "V6" or "7S" and it is recommended that you start with a program size of 2K.

```
generic map(
  C_FAMILY => "7S",
  C_RAM_SIZE_KEYWORDS => 2,
  C_JTAG_LOADER_ENABLE => 1)
```

Start by setting the 'C_JTAG_LOADER_ENABLE' generic to '1' as this will automatically include the JTAG Loader circuitry that will help you to rapidly develop your program. Note that if you do have multiple KCPSM6 program memories in your design only one should have this generic set at a time.

Starting 'your_program.psm'

Any KCPSM6 based design faces a 'chicken and egg' situation because you are defining both the hardware in your HDL design and writing a the software program for the processor to execute. Once you are familiar with using KCPSM6 you will resolve this naturally but if this is your first time using any PicoBlaze then please just follow the flow being described in these pages and it will all fit together.

So far you have inserted the program memory and connected it in your HDL design. You have assigned that component a name to correspond with your program (this document has shown that name to be 'your_program') but as yet you do not have a program. More significantly you do not have the corresponding HDL file that the assembler generates. To resolve this situation the next step is to start your KCPSM6 program and run the assembler for the first time. At this stage the program only needs to act as a place keeper so you don't need to actually write a real program yet ; it only has to be a file to present to the KCPSM6 assembler.

Making a PSM file

A program for KCPSM6 is written as a standard text file and then saved with the '.psm' file extension. As such you are free to use whatever text editor you prefer and WordPad supplied as an Accessory in Windows is more that adequate as shown in this example.

If this is your first experience of using PicoBlaze then start your first program by copying this example (that does nothing!) as it will be adequate at this stage.

Then save your program in your working directory as plain text with the '.psm' extension. Check that it really is in your working directory with the correct name (e.g. 'your_program.psm' and not something like 'your_program.psm.txt') and to be sure reopen the file in your text editor and check that it still looks Ok.

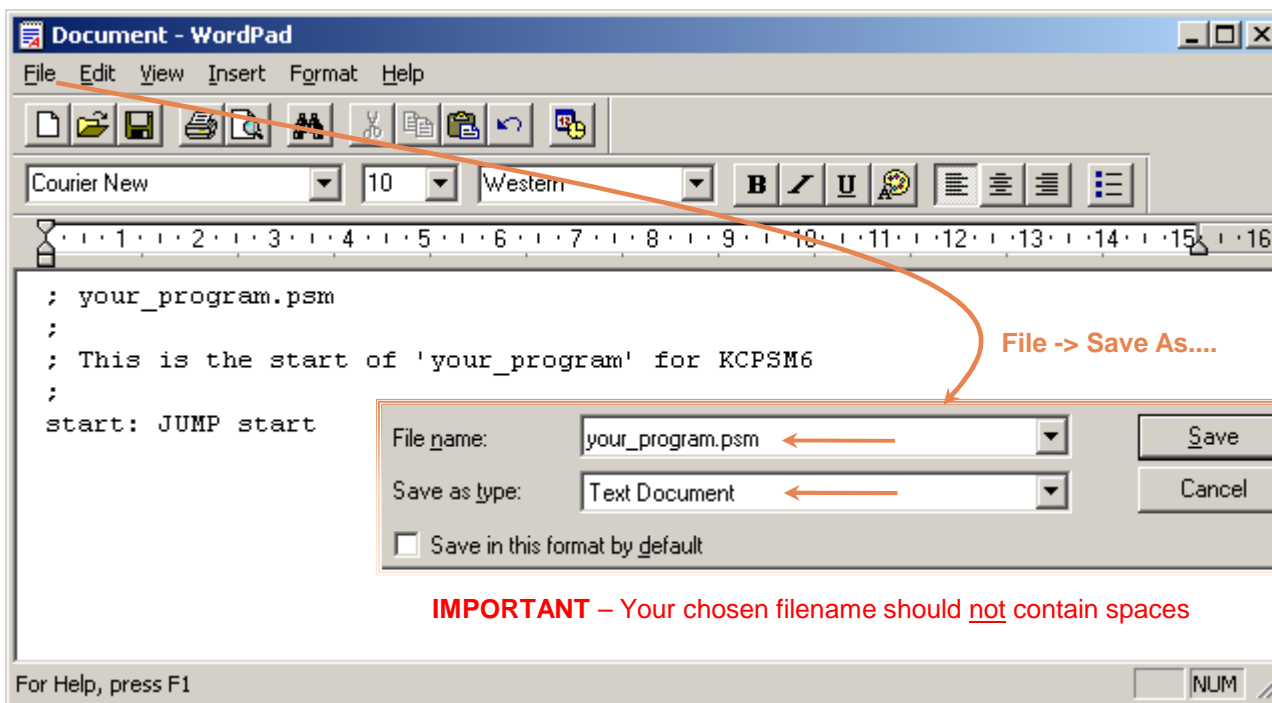

Hint – A semicolon (;) is used to start a comment so feel free to write whatever you like in your PSM program.

Running the Assembler for the First Time

If using ISE v13.x or later then continue reading and having fun but if you are still using ISEv12.x please check READ_ME_FIRST.txt to prepare.

The easiest way to use the KCPSM6 assembler is in interactive mode within your working directory. In order to be able to do this, copy 'kcpsm6.exe' and the default 'ROM_form.vhd' (or .v) file from the ZIP file into the working directory containing 'your_program.psm'.

Name	Size	Type	Date Modified
your_program.psm	1 KB	PSM File	23/09/2010 12:24
kcpsm6.exe	138 KB	Application	17/09/2010 13:41
ROM_form.vhd	95 KB	VHD File	17/09/2010 11:51

Hint – Copy 'kcpsm6.vhd' into your working directory at the same time.

```
kcpsm6.exe
KCPSM6 Assembler v2.46
Ken Chapman - Xilinx Ltd - 18th February 2013

Enter name of PSM file: your_program.psm

Reading top level PSM file...
C:\Data\chapman\PicoBlaze_Designs\your_program.psm

A total of 28 lines of PSM code have been read

Checking line labels
Checking CONSTANT directives
Checking STRING directives
Checking TABLE directives
Checking instructions

Writing formatted PSM file...
C:\Data\chapman\PicoBlaze_Designs\your_program.fmt

Expanding text strings
Expanding tables
Resolving addresses and Assembling Instructions
Last occupied address: 004 hex
Nominal program memory size: 1K (1024) address(9:0)
Occupied memory locations: 5
Assembly completed successfully

Writing LOG file...
C:\Data\chapman\PicoBlaze_Designs\your_program.log
Writing HEX file...
C:\Data\chapman\PicoBlaze_Designs\your_program.hex
Writing VHDL file...
C:\Data\chapman\PicoBlaze_Designs\your_program.vhd

KCPSM6 Options.....
R - Repeat assembly with 'your_program.psm'
N - Assemble new file.
Q - Quit
```

Double click on 'kcpsm6.exe' to launch the assembler which will open the KCPSM6 window.

You will be prompted to 'Enter name of PSM file:' so type in the name you have given for your program. You can include the '.psm' file extension if you like typing!

The assembly of any simple program is very fast and unless you made a mistake (which it would tell you about) the assembly will be successful.

Name	Size	Type	Date Modified
your_program.psm	1 KB	PSM File	23/09/2010 12:24
kcpsm6.exe	138 KB	Application	17/09/2010 13:41
ROM_form.vhd	95 KB	VHD File	17/09/2010 11:51
your_program.fmt	1 KB	FMT File	23/09/2010 13:34
your_program.hex	28 KB	HEX File	23/09/2010 13:34
your_program.log	1 KB	Text Document	23/09/2010 13:34
your_program.vhd	127 KB	VHD File	23/09/2010 13:34

Then most important of all, the assembler generates the 'your_program.vhd' (or .v) definition of the program memory ready for you to include in your ISE project. The assembler has also generated '.fmt', '.hex' and '.log' files which we can look at more later.

You are presented with some simple options but in a while you will modify 'your_program.psm' and it will be easier to leave the assembler window open and then choose 'R'...

Adding the Source Files to Your ISE Project

KCPSM6 can also be used in a Vivado project but the images below are for ISE Project Navigator.

As previously stated this document is not intended to teach you how to use ISE but simply to remind you of the steps required. At this point you can add the 'kcp6.vhd' and 'your_program.vhd' files (or their verilog equivalents) to your ISE project.

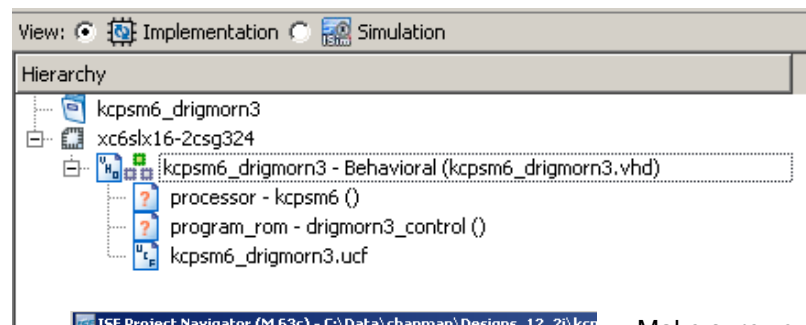

Assuming your design file is already in your ISE project and you have saved that files since including the KCPSM6 and program memory components then the 'Hierarchy' view should show the processor and program ROM but with '?' indicating that no files are associated with them.

Hint – In these screen shots of ISE the KCPSM6 program was called 'drigmorn3_control'

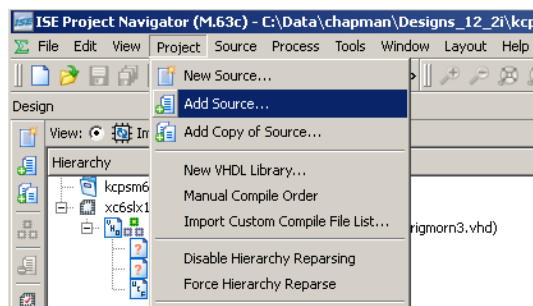

Make sure you have the 'kcp6.vhd' and 'your_program.vhd' files to your working directory, then use the 'Project -> Add Source...' option to locate and add them to your project.

This should complete the hierarchy (no '?' symbols) of your ISE project. The program memory includes the definition of the JTAG Loader utility (even if it is not actually enabled the definition will be present) .

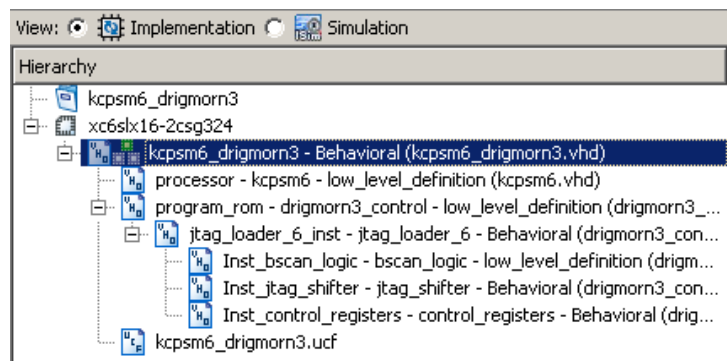
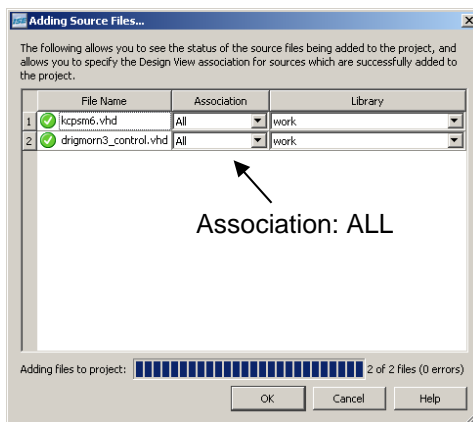
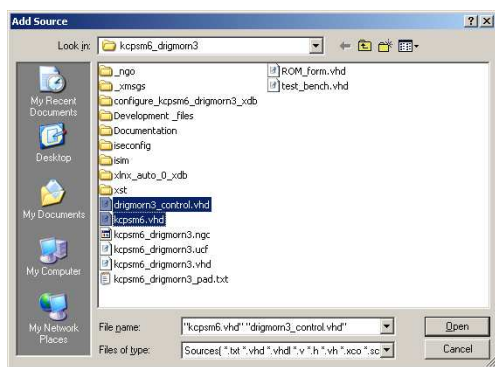

Programmable² Design – Adding I/O Ports

Your design now includes KCPSM6 and its associated program memory but as yet it is not connected to anything else. This is the point at which every design is going to be different depending on the application. However, in all cases the primary interface between KCPSM6 and the rest of your design is made using input and output ports. Whether you need a few or many, the method is the same.

Programmable² Design

The key advantage of a Field Programmable Gate Array (FPGA) is that you can define, program, modify and re-program your hardware. As such it makes a lot of sense to develop a design in stages. Start with something simple, perform experiments and tests to get it working and then expanding the design as you gain confidence. This is of particular value when bringing unproven hardware to life for the first time where simple designs whose only purpose is to prove that the board and pin connections are correct often prove to be invaluable. In contrast, the person or team that develop their entire complex design using simulation tools then often spend months trying to debug simple hardware issues.

Including KCPSM6 in your design means that you now have the benefit of software programmability embedded within your hardware. However, that degree of flexibility is only truly beneficial if the interface between software in the KCPSM6 processor and the hardware is correct to begin with. So once again the key to success is to start simple and build up. As you will see, it takes less than 10 seconds to modify a KCPSM program and have it executing within your design so simple experiments to prove functionality become so natural that you soon forget that you are exploiting programmable² every day.

Whatever Your Design – Start Simple!

Unless you are an experienced PicoBlaze designer or starting with a known good platform and reference it is always best to start with something simple and then to expand. The following pages will take you through one simple case study that connects KCPSM6 to the switches, press buttons and LEDs on the Virtex-6 FPGA Evaluation Kit. Whatever the hardware you have access to, try to start with something at least as simple as this.

The ML605 board has a row of 8 DIP switches and a row of 8 general purpose LEDs. Although adjacent on the board there is no direct connection between them but they all connect to pins on the Virtex-6 device.

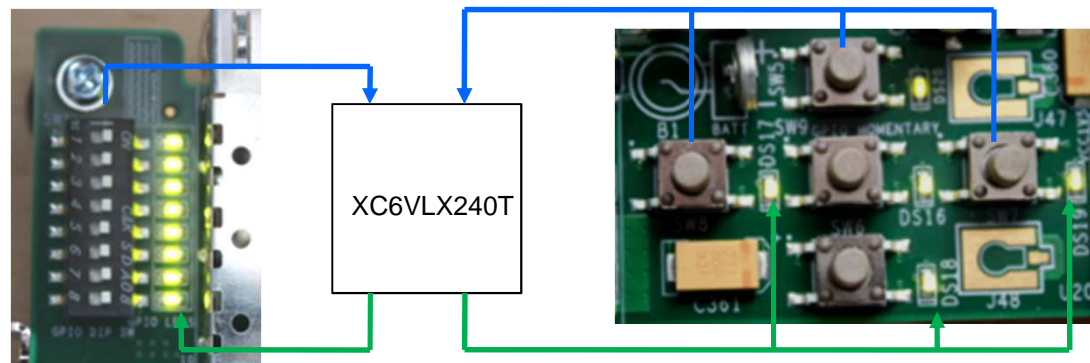

In a similar way there are 5 'direction' push buttons with adjacent LEDs.

Output Ports

KCPSM6 can output 8-bit values to up to 256 general purpose output ports using its 'OUTPUT sX, pp' and 'OUTPUT sX, (sY)' instructions. A complete description is provided in the reference section later in this document but here we can see this put into practice so that KCPSM6 can control the 8 general purpose LEDs and 5 'direction' LEDs on the ML605 board.

Please see next page for the corresponding VHDL and PSM

When KCPSM6 executes an 'OUTPUT' instruction it sets 'port_id' to specify which of 256 ports it wants to write the 8-bit data value present on 'out_port'. A single clock cycle enable pulse is generated on 'write_strobe' and **your hardware must use 'write_strobe' to qualify the decodes of 'port_id'** to ensure that only the correct register (or peripheral) captures the 'out_port' value.

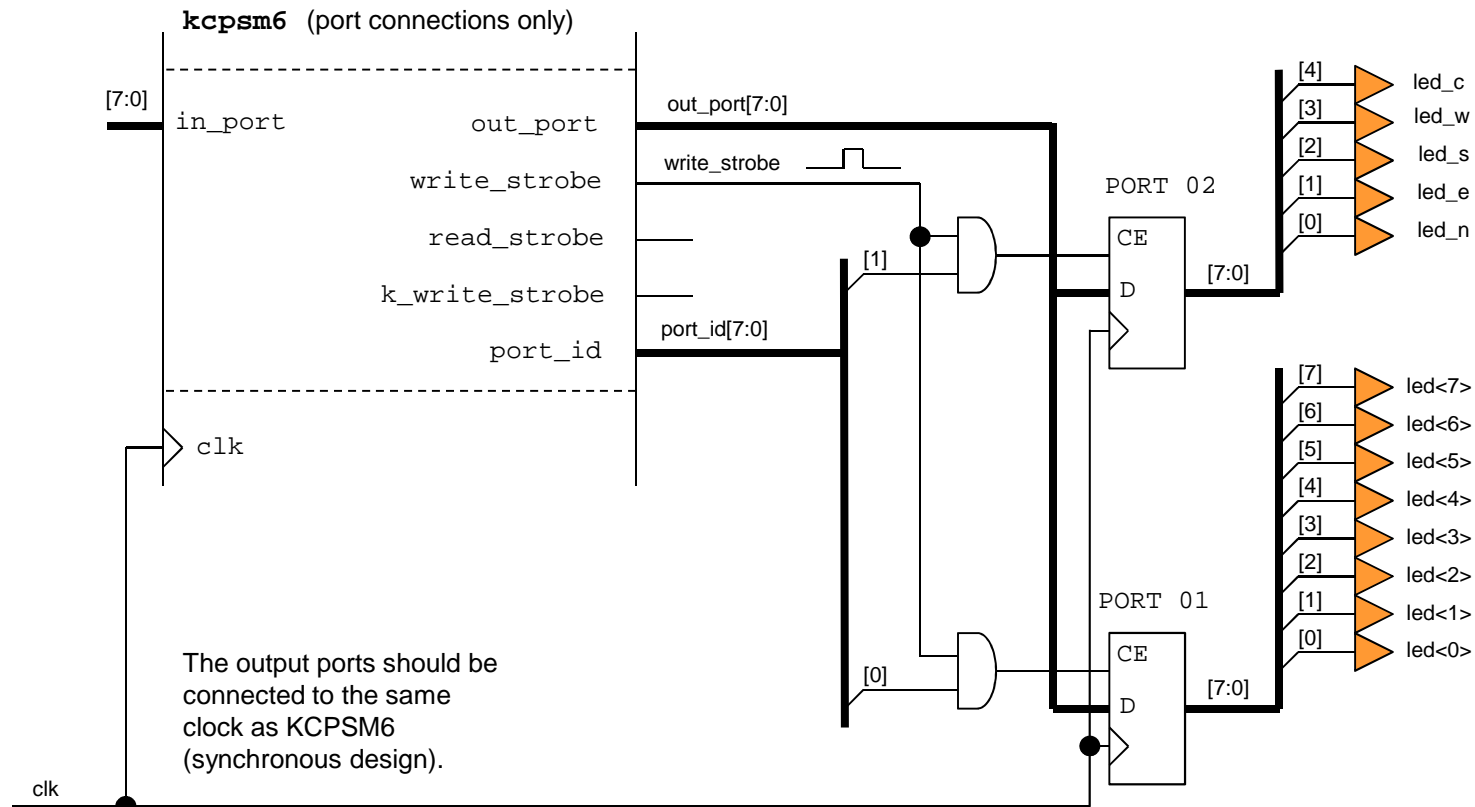

Output Ports.... VHDL and PSM

VHDL corresponding with circuit diagram of output ports shown on the previous page.

```
output_ports: process(clk)
begin
  if clk'event and clk = '1' then
    if write_strobe = '1' then

      -- 8 General purpose LEDs at port address 01 hex
      if port_id(0) = '1' then
        led <= out_port;
      end if;

      -- Direction LEDs at port address 02 hex
      if port_id(1) = '1' then
        led_n <= out_port(0);
        led_e <= out_port(1);
        led_s <= out_port(2);
        led_w <= out_port(3);
        led_c <= out_port(4);
      end if;

    end if;
  end if;
end process output_ports;
```

Output ports should be synchronous with the same clock used by KCPSM6. Writes to general purpose output ports must be qualified with 'write_strobe'.

Decode the 'port_id' to enable only the appropriate port to be written.

The majority of PicoBlaze designs use far less than the 256 output ports available so it is best practice to allocate ports such that the decoding logic can be minimised (smaller and faster) as shown here. For full -8-bit decoding the equivalent code would be....

```
if port_id = X"01" then
```

KCPSM6 always presents an 8-bit value on 'out_port' but you can assign individual bits as required and use only the number of bits you need.

As you assign your output ports in your hardware design take the opportunity to define constants in 'your_program.psm'. The assembler has a CONSTANT directive which enables you to define a unique name (case sensitive no spaces) and assign it a value. You can study more details about assembler syntax later but hopefully just seeing this example makes it fairly obvious.

Hint – Although CONSTANT directives are optional they make programs much easier to write, modify, understand, maintain and re-use in comparison to always specifying absolute port addresses in 'OUTPUT' instructions.

PSM corresponding with circuit diagram and VHDL

```
; 8 General Purpose LEDs
CONSTANT LED_port, 01
;
; 5 Direction LEDs
CONSTANT Direction_LED_port, 02
; Bit assignments for each LED/button
CONSTANT North, 00000001'b ; North - bit0
CONSTANT East, 00000010'b ; East - bit1
CONSTANT South, 00000100'b ; South - bit2
CONSTANT West, 00001000'b ; West - bit3
CONSTANT Centre, 00010000'b ; Centre - bit4
```

Input Ports

KCPSM6 can read 8-bit values from up to 256 general purpose input ports using its 'INPUT sX, pp' and 'INPUT sX, (sY)' instructions. A complete description is provided in the reference section later in this document but here we can see this put into practice so that KCPSM6 can read the 8 DIP switches and 5 'direction' push buttons on the ML605 board.

Please see next page for the corresponding VHDL and PSM

When KCPSM6 executes an 'INPUT' instruction it sets 'port_id' to specify which of 256 ports it wants to read from and it is the task of the hardware circuit to present that 8-bit data to the 'in_port'. A simple multiplexer can be used to achieve this. It is best practice to pipeline the output of the multiplexer and to only use the appropriate number of bits of 'port_id' to facilitate the number of input ports actually required.

Hint – Failure to pipeline the input multiplexer and fully decoding 'port_id' when only a few input ports are actually used are the most common reasons for a PicoBlaze design not meeting performance.

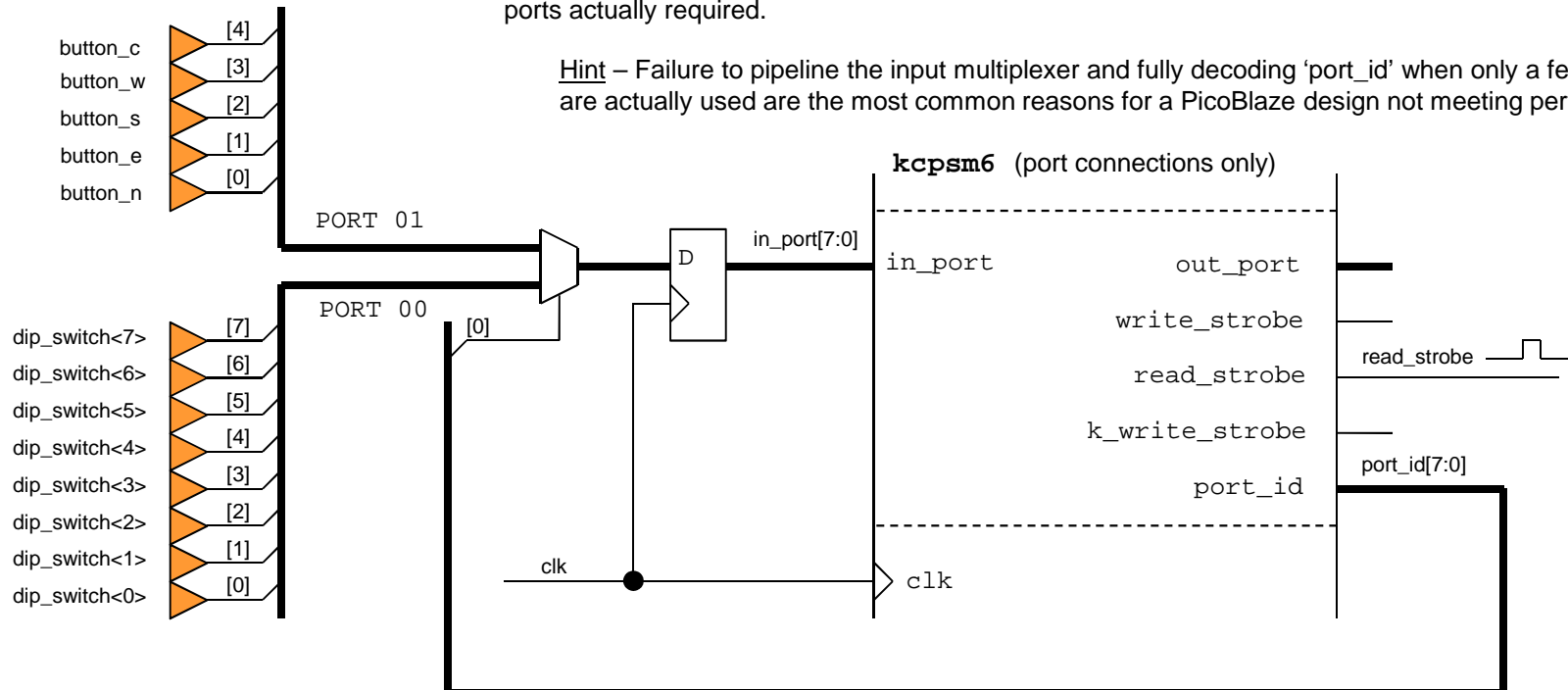

Hint - The 'read_strobe' is also pulsed High when KCPSM6 executes an 'INPUT' instruction but this does not need to be used to qualify the multiplexer selection. This strobe would be used in situations where the circuit being read needs to know when data has been captured. The most obvious example is reading data from a FIFO so that it can discard the oldest information and present the information to be read on its output.

Input Ports.... VHDL and PSM

VHDL corresponding with circuit diagram of input ports shown on the previous page.

```
input_ports: process(clk)
begin
  if clk'event and clk = '1' then
    case port_id(0) is
      -- Read 8 DIP switches at port address 00 hex
      when '0' => in_port <= dip_switch;

      -- Read 5 Push Buttons at port address 01 hex
      when '1' => in_port(0) <= push_n;
                  in_port(1) <= push_e;
                  in_port(2) <= push_s;
                  in_port(3) <= push_w;
                  in_port(4) <= push_c;

      when others => in_port <= "XXXXXXXX";

    end case;
  end if;
end process input_ports;
```

The input port selection multiplexer should be pipelined and synchronous with KCPSM6 (i.e. use the same clock as connected to KCPSM6).

Limit the number of bits of 'port_id' used to those necessary to select the number of inputs that you have. For example if you had 5 to 8 input ports then your code would take the general form shown below....

```
case port_id(2 downto 0) is
  when "000" => in_port <= dip_switch;
  when "001" => in_port <=
```

Assign the 8-bit data to 'in_port' as required.

For smallest and fastest hardware always use 'don't care' to cover the unused cases and bit assignments. Your KCPSM6 program should not read unused ports and can mask/ignore bits that have no meaning.

As with the output ports, take the opportunity to define constants in 'your_program.psm' corresponding to your allocations of input ports in your hardware design. Hopefully this is all beginning to make sense and already beginning to look familiar!

Hint – The previously defined constants North, South, East, West and Centre can apply to both the direction LEDs and direction buttons because of the consistent allocation of the bits within those ports.

PSM corresponding with circuit diagram and VHDL

```
; 8 DIP Switches
CONSTANT Switch_port, 00
;
; 5 Direction Push Buttons
CONSTANT Direction_Button_port, 01
```

Some First Instructions for 'your_program.psm'

```
your_program.psm - WordPad
File Edit View Insert Format Help
[Icons]
; your_program.psm
;
; This is the start of 'your_program' for KCPSM6
;
; 8 General Purpose LEDs
CONSTANT LED_port, 02
;
; 5 Direction LEDs
CONSTANT Direction_LED_port, 04
CONSTANT North, 00000001'b ; North - bit0
CONSTANT East, 00000010'b ; East - bit1
CONSTANT South, 00000100'b ; South - bit2
CONSTANT West, 00001000'b ; West - bit3
CONSTANT Centre, 00010000'b ; Centre - bit4
;
; 8 DIP Switches
CONSTANT Switch_port, 00
;
; 5 Direction Push Buttons
CONSTANT Direction_Button_port, 01
;
start: INPUT s0, Switch_port
OUTPUT s0, LED_port
INPUT s1, Direction_Button_port
OUTPUT s1, Direction_LED_port
JUMP start
```

As you have been defining the hardware input and output ports connected to KCPSM6 you should have been adding the corresponding CONSTANT directives to your PSM file. So hopefully it looks something like the file shown here. However, the program still doesn't actually do anything until we include some somewhat meaningful instructions.

Hint – Anything written on a line following a semicolon (;) is a comment and so you can add any notes that you like.

CONSTANT directives to help identify port assignments and also the allocation of bits within a port.

A Simple Test Program

The key is to start with something simple that will help you to verify your hardware, your hardware design and the corresponding port assignments in the PSM file. In this case the program is just going to read the switches and output their values to the LEDs. Likewise it will read the direction press buttons and output their values to the corresponding direction LEDs.

Each INPUT instruction reads the value from a specified port into one of the general purpose registers (registers are named 's0', 's1, through to 'sF'). Likewise the OUTPUT instructions write the contents of registers to the specified ports.

So that the program continuously repeats a JUMP instruction is used to 'loop' back to the start of the program. 'start:' is a 'line label' and this lets the assembler work out the actual program address for you.

Hint – If something did not work properly in this example it would be good to try driving the LEDs with a known pattern (A5 = "10100101") to determine if it was the input or output path that was incorrect.

```
LOAD s0, A5
OUTPUT s0, LED_port
```

Assemble 'your_program.psm' (again)

```
kcpsm6.exe
KCPSM6 Assembler v2.46
Ken Chapman - Xilinx Ltd - 18th February 2013

Enter name of PSM file: your_program.psm

Reading top level PSM file...
C:\Data\chapman\PicoBlaze_Designs\your_program.psm

A total of 28 lines of PSM code have been read

Checking line labels
Checking CONSTANT directives
Checking STRING directives
Checking TABLE directives
Checking instructions

File: your_program.psm
Path: C:\Data\chapman\PicoBlaze_Designs
Line: 24

start: INPUT s0, switch_port

ERROR - Invalid second operand: switch_port
The second operand of INPUT should define the
target location with one of the following...
The contents of a register e.g. (s4)
Hexadecimal value in the range '00' to FF'
Decimal value in the range 0'd to 255'd
The (case sensitive) name defined in a CONSTANT directive

KCPSM6 Options.....
R - Repeat assembly with 'your_program.psm'
N - Assemble new file.
Q - Quit
```

Each time you modify your PSM file you need to run the assembler again so that the changes are also included in the HDL program memory definition file.

Hint – Even though the assembly process is fast it can become tiresome to keep entering the name of your program. There are several solutions to this including the use of batch files but probably the most elegant technique during code development is to keep the assembler open (i.e. Do not 'Q'uit or manually close the window) and then use the 'R' option each time you need to repeat the assembly process with the same file.

If you should make any mistakes in your PSM program then the assembler will identify the PSM file and the line in that file that it can not resolve and make suggestions for you to be able to rectify the issue.

In this example my mistake was using a lower case 's' in 'switch_port' when the constant directive had specified it to be 'Switch_port'.

Use 'R' once you have made any changes or corrections to your PSM file.

The Formatted PSM File (.fmt)

Use of the FMT file is completely optional but even this small example illustrates that the KCPSM6 assembler can help your code look tidy and professional. Over time you will discover that the assembler is very tolerant of the way that you space items on a line and the use of upper and lower case characters when entering instructions and directives. This enables you to write code quickly but this will also tend to make your code look untidy and difficult to maintain. So from time to time it is recommended that you discard your original PSM file and simply rename the '.fmt' file to make it your new tidy '.psm' file.

your_program.psm

```
; your_program.psm
;
; This is the start of 'your_program' for KCPSM6
;
; 8 General Purpose LEDs
CONSTANT LED_port, 01
;
; 5 Direction LEDs
CONSTANT Direction_LED_port, 02
CONSTANT North, 00000001'b; North - bit0
CONSTANT East, 00000010'b; East - bit1
CONSTANT South, 00000100'b; South - bit2
CONSTANT West, 00001000'b; West - bit3
CONSTANT Centre, 00010000'b; Centre - bit4
;
; 8 DIP Switches
CONSTANT Switch_port,00
;
; 5 Direction Push Buttons
CONSTANT Direction_Button_port, 01
;
start: INPUT s0, Switch_port
OUTPUT s0, LED_port
input s1,Direction_Button_port
OUTPUT s1, Direction_LED_port
Jump start
```

KCPSM6

your_program.fmt

```
; your_program.psm
;
; This is the start of 'your_program' for KCPSM6
;
; 8 General Purpose LEDs
CONSTANT LED_port, 01
;
; 5 Direction LEDs
CONSTANT Direction_LED_port, 02
CONSTANT North, 00000001'b      ; North - bit0
CONSTANT East, 00000010'b      ; East - bit1
CONSTANT South, 00000100'b     ; South - bit2
CONSTANT West, 00001000'b     ; West - bit3
CONSTANT Centre, 00010000'b    ; Centre - bit4
;
; 8 DIP Switches
CONSTANT Switch_port, 00
;
; 5 Direction Push Buttons
CONSTANT Direction_Button_port, 01
;
start: INPUT s0, Switch_port
OUTPUT s0, LED_port
INPUT s1, Direction_Button_port
OUTPUT s1, Direction_LED_port
JUMP start
```

Hint – A typical batch file that makes a back up of the PSM file before replacing it with the FMT file.

```
copy your_program.psm previous_your_program.psm
del your_program.psm
copy your_program.fmt your_program.psm
```

Ready to Download

You have done everything there is to do!...

You have put KCPSM6 into your HDL design and included the 'kcpsm6.vhd' file in your ISE project.

You have connected a program memory to KCPSM6 setting the generics to define the target device, memory size and enable JTAG Loader utility.

You have started a simple PSM program, assembled it and included the program memory definition file 'your_program.vhd' file in your ISE project.

You defined some output ports connected to the 'port_id', 'out_port' and 'write_strobe' signals.

You defined some input ports connected to the 'port_id' and 'in_port' signals.

You have added CONSTANT directives to your PSM to give the ports meaningful names and define their addresses.

You have written the most simple test program and run the assembler again to make sure that file 'your_program.vhd' contains that program.

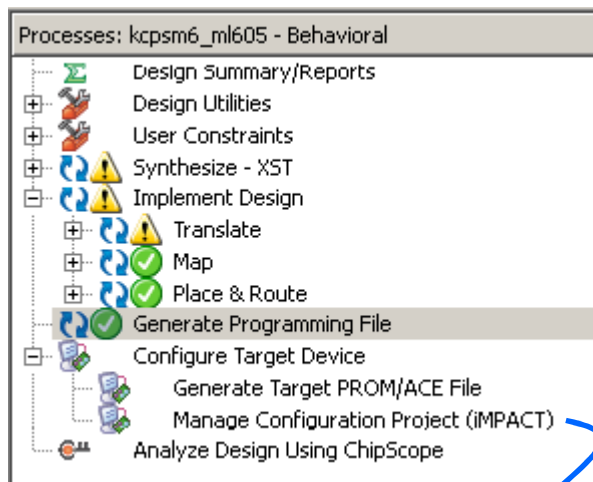

So as long as you have everything else ready in your design (e.g. UCF file defining pins and timing specifications etc) you should be able to synthesize, Map, Place & Route your design and generate the configuration programming file (.bit).

Note - When using XST in ISE v12.x or v13.x the warning shown below will be generated associated with 'kcpsm6.vhd'. Unfortunately this is an erroneous message and should not occur when using v14.x or later. This warning can be safely ignored but any others associated with KCPSM6 in your design should be given further consideration.

WARNING:Xst:647 - Input <instruction<0:11>> is never used. This port will be preserved and left unconnected if it belongs to a top-level block or it belongs to a sub-block and the hierarchy of this sub-block is preserved.

Hint – The warning message shown below is quite common especially in simple KCPSM6 designs. It is a genuine warning message but can be safely ignored because it relates to the fact that 'read_strobe' does not need to be used when implementing INPUT ports (see 'INPUT ports' in this example).

WARNING:NgdBuild:443 - SFF primitive 'processor/read_strobe_flop' has unconnected output pin

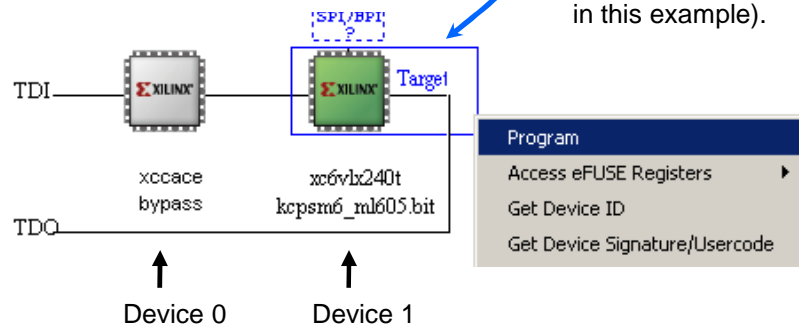

Then connect your download cable, open iMPACT and program the device. Does your simple test design work? My switches and LEDs do ☺

Note – Next we are going to exploit the JTAG chain in order to modify the KCPSM6 program so make a quick note of which devices are in your chain and which device 'your_program' is located in. In this example it is device '1'.

Hint – The first device in any chain is device '0' (not '1').

JTAG Loader

Requires ISE v12.x or later

Running your design through the ISE tools and configuring the device didn't take long compared with procuring an ASIC (and it certainly didn't cost as much), but even so, it would become a huge waste of time if you had to do that every time you modified your KCPSM6 program and wanted to try it out. For this reason the JTAG Loader utility exists to enable you to download a new program directly into the program memory inside the Spartan-6, Virtex-6 or 7-Series device whilst it remains configured and active with your design.

You will see that with JTAG Loader it is possible to modify your program and then have it running in KCPSM6 in under 10 seconds. With this rapid facility it is possible to develop your programs iteratively taking many small steps and trying out each as you go. Including temporary code to perform and experiment or help debug your program or test something else in your system becomes quick and easy.

Preparing to use JTAG Loader

If you are following this worked example then you have already done the main things but if you are only looking at this section for the first time then you do need to prepare the program memory in your design as shown here.

```
1 program_rom: your_program
  generic map(
    C_FAMILY => "S6",
    C_RAM_SIZE_KEYWORDS => 1,
    C_JTAG_LOADER_ENABLE => 1) ←
  port map(
    address => address,
    instruction => instruction,
    enable => bram_enable,
    rd1 => kcpsm6_reset,
    clk => clk);
```

The program memory should be generated by the assembler using the default 'ROM_form' template (also supplied as 'ROM_form_JTAGLoader_14March13.vhd') and the 'C_JTAG_LOADER_ENABLE' generic value must be set to '1'. If you have multiple KCPSM6 in your design then make sure that you only enable JTAG Loader on one program memory at a time.

- 2 Generate the configuration BIT file for your design and configure the target device using iMPACT and JTAG.

Hint – Boards like the SP605 and ML605 have the circuits of the 'Platform Cable USB' built on to them and boards like ATLYS, KC705 and VC707 have the equivalent Digilent circuit on them. It is best if you only have the equivalent of one download cable connected to your PC at a time.

- 3 Copy the 'JTAG Loader' executable *corresponding with your operating system* from the ZIP file into your working directory.

- 4 Open a 'Command Prompt' (i.e. DOS Window) and navigate to your working directory.

IMPORTANT -The Command Prompt must know the location of your Xilinx ISE installation so both 'Path' and 'XILINX' environment variable must be defined. There are three ways in which you can achieve this:-

- Permanently define 'Path' and 'XILINX' in your your system environment; please see the 'Requirements' section of 'READ_ME_FIRST.txt' for details.
- Use the ISE Design Suite Command Prompt (see right).
- Run the 'settings32.bat' or 'settings64.bat' provided in C:\Xilinx\14.3\ISE_DS (or equivalent for your version of ISE and its location on your PC).



JTAG Loader

Requires ISE v12.x or later

```

c:\VID
C:\Data\chapman\PicoBlaze_Designs>jtagloader

          JTAG Loader
-----
JTAG Loader by Kris Chaplin, Xilinx UK
Build : Date: Apr 24 2012. Time: 14:31:08
Target: Microsoft Windows XP Service Pack 3, 32-bit.
Use the -h option if you need help

Info:=====
Info:CABLE name used in scanChain: auto, cableArgCount=0
Info:=====
Info:Digilent Plugin: no JTAG device was found.
Info:AutoDetecting cable. Please wait.
Info:Connecting to cable (Usb Port - USB21).
Info:Checking cable driver.
Info: Driver file xusbdfwu.sys found.
Info: Driver version: src=1027, dest=1027.
Info: Driver windrvr6.sys version = 10.2.1.0. Info: WinDriver v10.21 Jungo (c) 19
97 - 2010 Build Date: Aug 31 2010 X86 32bit SYS 14:35:41, version = 1021.
Info: Cable PID = 0008.
Info: Max current requested during enumeration is 74 mA.
Info:Type = 0x0004.
Info: Cable Type = 3, Revision = 0.
Info: Setting cable speed to 6 MHz.
Info:Cable connection established.
Info:Firmware version = 1303.
Info:File version of C:/Xilinx/13.4/ISE_DS/ISE/data/xusb_xlp.hex = 1303.
Info:Firmware hex file version = 1303.
Info:PLD file version = 0012h.
Info: PLD version = 0012h.
Info:Type = 0x0004.
Info:ESN option: 000013C2006801.
Info:Open cable successfully
Info:Obtained cable lock
Info:Found 2 devices
Device 0: System_ACE_CF          [Bypass]
Device 1: XC6VLX240T            [FPGA with user registers]
Scan completed
AutoDetected FPGA target as Device 1
Detected that target device 1 is configured
=====
Number of PicoBlazes in system : 1
Maximum BlockRAM Data Width   : 18
PicoBlaze : 0 Reset : 0 Address Width : 11
=====
JTAG Loader has completed successfully
C:\Data\chapman\PicoBlaze_Designs>

```

For simplicity, this documentation assumes that the executable required for your operating system has been renamed 'jtagloader'.

Confirming Setup - Assuming you have performed the simple preparatory steps described on the previous page then enter 'jtagloader' to run the JTAG Loader utility (please see the note about name in the yellow box). The result should be similar to the screen shown here.

If for any reason the utility fails then read any messages displayed as they should indicate the reason. Check again the preparatory steps shown on the previous page and also look in the 'READ_ME_FIRST.txt' file for further guidance.

Given that you have previously configured the target FPGA using iMPACT there is normally no difficulty for JTAG Loader to automatically detect your download cable and the PicoBlaze memory in your design.

Hint - 'jtagloader -h' will provide a brief description of all the options including '-u' and '-p' which can be used to force the selection of the Platform Cable USB or Digilent equivalent respectively.

JTAG Loader determines which devices are in the JTAG chain and this should match with what you saw in iMPACT (see 2 pages previous).

JTAG Loader tries to make an intelligent choice for the target FPGA and will report the size of the program memory that it finds in that device.

Hint - To override the automatic device selection use 'jtagloader -t#' and set # to the chain position of the FPGA you do want to target (e.g. -t3). Note that first device in the chain is '-t0'.



JTAG Loader With 3rd Party JTAG Devices

```
ISE Design Suite Command Prompt

JTAG Loader
JTAG Loader by Kris Chaplin, Xilinx UK
Use the -h option if you need help

Info:Connecting to cable (Usb Port - USB21).
Info:Checking cable driver.
Info: Driver file xusbdfwu.sys found.
Info: Driver version: src=1027, dest=1027.
Info: Driver windrvr6.sys version = 10.1.1.0. Info: WinDriver v10.11 Jungo (c) 19
97 - 2010 Build Date: Jan 17 2010 X86 32bit SYS 18:30:22, version = 1011.
Info: Cable PID = 0008.
Info: Max current requested during enumeration is 74 mA.
Info:Type = 0x0004.
Info: Cable Type = 3, Revision = 0.
Info: Setting cable speed to 3 MHz.
Info:Cable connection established.
Info:Firmware version = 1303.
Info:File version of C:\Xilinx\12.2\ISE_DS\ISE\data\xusb_xlp.hex = 1303.
Info:Firmware hex file version = 1303.
Info:PLD file version = 0012h.
Info: PLD version = 0012h.
Info:Type = 0x0004.
Info:ESM option: 000013C2146E01.
Info:Open cable successfully
Info:Obtained cable lock
Info:Found 3 devices
Unknown device in chain IDcode 4f1f0f0f
Checking idcodes.lst in the working directory for an entry for device 4f1f0f0f

** ERROR: An unknown JTAG device ID 4f1f0f0f was found in the jtag chain
** At JTAG position 0. Please read the vendor documentation for this
** JTAG device, and populate the IDCODE (4f1f0f0f) and IRLength
** fields into a new file "idcodes.lst" in this working directory.
** Please see the KCPSM6 documentation for more information

Device 1: System_ACE_CF [Bypass]
Device 2: XC6SLX45T [FPGA with user registers]
Scan completed
AutoDetected FPGA target as Device 2
Detected that target device 2 is configured
Error in shiftDeviceIR routine
*** A Failure was detected - Exiting ***
```

Failures due to "Unknown JTAG device(s)" in the chain

JTAG Loader will automatically detect if there are JTAG devices in the chain that are not known to the Xilinx tools. This is most likely to occur on custom hardware that has third-party hardware in the chain.

If this event occurs, JTAG Loader will look for a "idcodes.lst" file in the directory from which it was called. The purpose of this file is simply to be a lookup table defining the Instruction Register (IR) length of any unknown devices. This is the only extra information that is needed.

Your third party device vendor should be able to provide you with a "BSDL" file describing the device; it is a text file describing the JTAG abilities and registers that it has. Open this file, and look for the line specifying "INSTRUCTION_LENGTH". In this example the device the length is "4".

```
TextPad - C:\Program Files\Texas Instruments Fusion Digital Power Designer\misc\ucd30xx.bsdl

ucd30xx.bsdl

-- Specifies the number of bits in the instruction register.
attribute INSTRUCTION_LENGTH of top_9240: entity is 4;
```

Modify, or create the file "idcodes.lst" to include the device ID (reported by JTAG loader) and the IR Register Length (from the BSDL file).

```
idcodes.lst - Notepad

fafecafe 12
4f1f0f0f 4
deadc0de 8
```

The next (hopefully successful!) run of JTAG loader will report that this information has been used.

```
Unknown device in chain IDcode 4f1f0f0f
Checking idcodes.lst in the working directory for an entry for device 4f1f0f0f
Match found, setting IR Length to 4
```

JTAG Loader

Requires ISE v12.x or later

Modifying 'your_program.psm'

The whole point of JTAG Loader is to enable you to download a new program into KCPSM6's program memory so really you need to modify your program in a way that you will be able to notice the difference. Obviously you will soon be working on a real application but initially look to make a simple change to your first test program.

```
start: LOAD s4, 00
flash: XOR s4, FF
      OUTPUT s4, LED_port
      OUTPUT s4, Direction_LED_port
      CALL delay_1s
      JUMP flash
      ;
      ; Software delay of 1 second
      ;
      ; ML605 is fitted with a 66MHz clock.
      ; 1 second is 66,000,000 clock cycles.
      ; KCPSM6 will execute 33,000,000 instructions.
      ;
      ; The delay loop below decrements the 24-bit value held
      ; in registers [s2,s1,s0] until it reaches zero and this
      ; loop consists of 4 instructions.
      ;
      ; Therefore the loop needs to count 8,250,000 times so
      ; the start value is 7DE290 hex.
      ;
delay_1s: LOAD s2, 7D
         LOAD s1, E2
         LOAD s0, 90
delay_loop: SUB s0, 1'd
          SUBCY s1, 0'd
          SUBCY s2, 0'd
          JUMP NZ, delay_loop
         RETURN
```

Continuing with the same example on the ML605 evaluation board this simple program has ignored the input ports and simply turns all the LEDs on both output ports on and off at 1 second intervals.

The program illustrates the use of a few more KCPSM6 instructions including a subroutine. All instructions are described in detail later in this guide but at this point it just describes something else that should be an obvious difference when executing on the ML605 board used in this case.

Generating the HEX file

Simply assemble the modified program and, as we have seen before, it will generate a '.hex' file which contains your modified program ready for JTAG Loader. There will also be a new '.vhd' file but that will only be used next time you invoke the ISE.

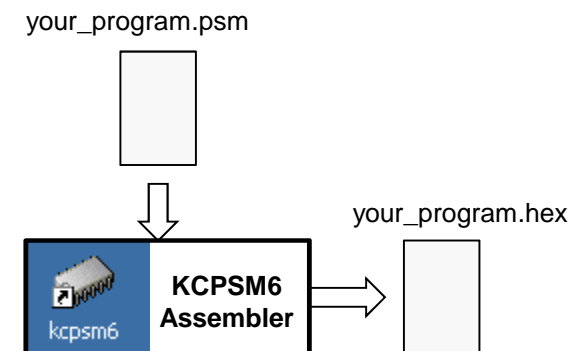

JTAG Loader

Requires ISE v12.x or later

```
C:\Data\chapman\PicoBlaze_Designs>jtagloader -l uart_control.hex

JTAG Loader
=====
JTAG Loader by Kris Chaplin, Xilinx UK
Build : Date: Apr 24 2012, Time: 14:31:08
Target: Microsoft Windows XP Service Pack 3, 32-bit.
Use the -h option if you need help

Load filename: uart_control.hex
Info:=====
Info:CABLE name used in scanChain: auto, cableArgCount=0
Info:=====
Info:Digilent Plugin: no JTAG device was found.
Info:AutoDetecting cable. Please wait.
Info:Connecting to cable (Usb Port - USB21).
Info:Checking cable driver.
Info: Driver file xusbdfwu.sys found.
Info: Driver version: src=1027, dest=1027.
Info: Driver windrvr6.sys version = 10.2.1.0. Info: WinDriver v10.21 Jungo (c) 19
97 - 2010 Build Date: Aug 31 2010 #86 32bit SYS 14:35:41, version = 1021.
Info: Cable PID = 0008.
Info: Max current requested during enumeration is 74 mA.
Info:Type = 0x0004.
Info: Cable Type = 3, Revision = 0.
Info: Setting cable speed to 6 MHz.
Info:Cable connection established.
Info:Firmware version = 1303.
Info:File version of C:\Xilinx\13.4\ISE_DS\ISE\data\xusb_xlp.hex = 1303.
Info:Firmware hex file version = 1303.
Info:PLD file version = 0012h.
Info: PLD version = 0012h.
Info:Type = 0x0004.
Info:ESN option: 000013C2006801.
Info:Open cable successfully
Info:Obtained cable lock
Info:Found 2 devices
Device 0: System ACE_CF [Bypass]
Device 1: XC6ULX240T [FPGA with user registers]
Scan completed
AutoDetected FPGA target as Device 1
Detected that target device 1 is configured
=====
Number of Picoblazes in system : 1
Maximum BlockRAM Data Width : 18

Picoblaze : 0 Reset : 0 Address Width : 11
=====
Initiating load of BlockRAM
Resetting PicoBlaze 0
Programming Bram
Releasing reset on PicoBlaze 0
Hex file appears to be in range for targeted BlockRAM
Counted 4096 lines in hex file, wrote 2048 (others if applicable were 0x0000)
JTAG Loader has completed successfully

C:\Data\chapman\PicoBlaze_Designs>
```

Downloading Your New Program

Simply run JTAG Loader again but this time specifying the name of the HEX file to be loaded into the KCPSM6 program memory.

```
jtagloader -l your_program.hex
```

That's a lower case 'L' ☺

Hint – If you needed to use an option to direct the loader to use a particular type of cable or to specify the target device in the chain then include those options again when loading.

E.g. `jtagloader -t1 -d -l your_program.hex`

Hint – The HEX file specification may include a PATH. If the path contains spaces then enclose within quotation marks.

E.g. `jtagloader -l "learning picoblaze\your_program.hex"`

Unless you have changed something then JTAG Loader should detect the cable, target device and program memory as before.

The loader will then force KCPSM6 into reset (using the 'rdl' signal you connected in your design) whilst the new program is written into the program memory. Finally, it releases the reset and KCPSM6 starts executing your new program from address zero. All in under 10 seconds.

A program can be up to 4K instructions but your physical program memory will often be only 1K or 2K. JTAG Loader checks that all the locations described in the HEX file that are beyond the end of the physical memory are unused (zero) or warns you if they are not (i.e. your program has become too big).

```
*** Error!! HEX file detected to be bigger than the blockram connected ***
```



That's It!

You really have seen how to include KCPSM6 in a design, write and assemble programs and rapidly make changes to your code. What applications you go on to implement using KCPSM6 is really down to you.

Of course there is more to learn about the instruction set but you can grow your understanding by reading the descriptions that follow and actually trying them. Some instructions are more advanced than others but try to build on success rather than struggle with a concept that you find difficult to begin with. In most cases it is possible to produce a solution in multiple ways so just do what you find most natural. As you gain experience you will probably recognise why certain other instructions and features are included and start to incorporate them in your programs and designs. Remember that with Programmabe² (programmable hardware a very rapid loading of KCPSM6 programs) you can experiment and try different techniques as much as you like.

Recommended for New PicoBlaze Users

So if KCPSM6 is your first experience of PicoBlaze design then hopefully you have already worked through all the pages of this guide prior to this one. If not, then please do! Having mastered the fundamentals, and ideally you will now have a working hardware platform containing a working KCPSM6 in front of you, it would be best if you focus on the following instructions as you write your first programs.

```
INPUT sX, pp
OUTPUT sX, pp
JUMP
LOAD
ADD / SUB
AND / OR / XOR
CALL / RETURN
JUMP Z / JUMP NZ / JUMP C / JUMP NC
COMPARE / TEST
STORE sX, ss
FETCH sX, ss
SL0 / SR0 / RL / RR
```

This may seem like quite a list to begin with. However, you have seen some of these used already and it really will not take long to understand what each of them does if you try them one out in your program. The description of each instruction contained later in this document includes example code. It may also feel a little daunting when you see that KCPSM6 has more instructions but do not feel under pressure to learn them all as you can achieve most things with this subset and they will help prepare you for the others.

Although you will learn most about the assembler language syntax from the examples given, it would be good to look at the more formal descriptions to understand the rules for line labels, register and constant names and the multiple ways in which you can specify constants. Take look at page 52 and in the file called 'all_kcpsm6_syntax.psm'.

Hint – The assembler is very tolerant about format and will advise you what to rectify so just try!

Hint – The ZIP file contains several simple but complete reference designs using the UART macros which are also provided with PicoBlaze (see UART directory for code and documents).

From a hardware perspective you have seen that KCPSM6 is small and connecting input and output ports is a straightforward piece of design. For completeness you should look at the fundamental waveforms associated with INPUT and OUTPUT operations (included in the description of those instructions) and also the waveforms and actions that occur at power up and during a RESET.

Hardware Reference

The following information provides more detailed descriptions of the hardware aspects of KCPSM6 and the associated program memory. All information is in addition to that contained in pages 6 to 29.

Please note that the waveforms and circuits associated with I/O ports are located with the descriptions of the 'INPUT', 'OUTPUT' and 'OUTPUTK' instructions.

Pin Descriptions

clk	Input	All operations are synchronous to this clock input. The clock should be provided using a clock buffer typically inserted automatically by the ISE tools. In the majority of applications the same clock will be used as the circuits KCPSM6 is expected to interact with as this ensures that all data transfers are synchronous and reliable. All timing internal to KCPSM6 would be covered by the time specification associated with the clock frequency or period. The maximum clock frequency will depend on the device type and speed grade as well as your design as a whole. However, it would be rare for KCPSM6 to be the single reason for a design failing to meet timing specifications as it is typically of higher performance than the peripheral logic you connect to it. All instructions execute in two clock cycles so KCPSM6 executes $\text{clk}/2$ instructions per second.
reset	Input	Active High reset control. When driven High for at least one rising edge of 'clk' KCPSM6 enters a reset state in which all activity ceases with the 'address' forced to zero, all strobes inactive and the 'bram_enable' Low to disable the program ROM. On release of reset ('0'), KCPSM6 starts up in a predictable sequence executing program code from address zero using register bank 'A' with interrupts disabled. Note that 'reset' should be connected to 'rdl' associated with the JTAG Loader utility during the development phase. If reset is not required during operation then tie the reset input permanently Low and the reset sequence will still be performed automatically following device configuration.
address[11:0]	Output	12-bit program address to access programs up to 4K instructions. This should be connected to the address inputs of the program ROM which is typically implemented using one or more BRAMs. The majority of programs are of 1K or 2K instructions and in these cases only the lower 10 or 11 bits of the address are actually used. Note that the memory templates provided always expect all 12-bits to be connected.
instruction[17:0]	Input	18-bit instructions. This port should be connected to the instruction (data) output of the program memory which is typically implemented using one or more BRAMs. Since BRAM are synchronous there is a one clock cycle latency from the address changing and the instruction being presented to KCPSM6.
bram_enable	Output	Read enable for the program memory. This signal should be connected to the enable input of the program memory and is used to reduce the power consumption associated with the BRAM(s) during normal operation as well as in sleep mode. This connection can be left open if program memory is permanently enabled (e.g. Distributed ROM).
sleep	Input	Active High sleep control. When driven High KCPSM6 will complete the current instruction and then enter a sleep mode in which all activity stops. Whilst in the sleep mode all strobes are inactive and the 'bram_enable' is Low to disable the program memory resulting in minimum power consumption. All inputs except 'reset' are ignored. When 'sleep' is returned Low, KCPSM6 resumes execution from the point that it stopped.

Pin Descriptions

interrupt	Input	Active High interrupt control. Providing interrupts have been enabled within the program then when this input is driven High KCPSM6 will perform an interrupt in which the address is forced to an interrupt vector (default 3FF but can be defined by the user) and the current states of the flags and register bank selection are preserved. Please see section on interrupts for more details.
interrupt_ack	Output	This output will pulse High for one clock cycle as KCPSM6 starts to service an interrupt by calling the interrupt vector. 'interrupt_ack' is generally used by the peripheral logic to cancel the interrupt signal to guarantee that no interrupts are missed and to ensure that each interrupt is only serviced once.
out_port[7:0]	Output	The port through which KCPSM6 presents 8-bit data to peripheral logic during 'OUTPUT' and 'OUTPUTK' instructions. This data is valid when 'write_strobe' or 'k_write_strobe' are active and 'port_id' will define the intended destination.
in_port[7:0]	Input	The port to which the peripheral logic must present 8-bit data for KCPSM6 to read during an 'INPUT' instruction. The peripheral logic should select and present the information based on the value of 'port_id'. When performing an INPUT operation the 'port_id' is valid for 2 clock cycles so it is highly recommended that the input data multiplexer be pipelined. Note that 'read_strobe' is not required to qualify the read process but may be required by the peripheral(s).
write_strobe	Output	This output will pulse High for one clock cycle when KCPSM6 executes an 'OUTPUT' instruction and the peripheral logic should capture the data provided on 'out_port' (on the next rising edge of the clock) into the intended destination defined by the value of 'port_id'.
k_write_strobe	Output	This output will pulse High for one clock cycle when KCPSM6 executes an 'OUTPUTK' instruction and the peripheral logic should capture the data provided on 'out_port' (on the next rising edge of the clock) into the intended destination defined by the value of 'port_id[3:0]'. Note that only the lower 4-bits of 'port_id' are used during 'OUTPUTK'.
read_strobe	Output	This output will pulse High for one clock cycle when KCPSM6 executes an 'INPUT' instruction and indicates that KCPSM6 will capture the data being presented on the 'in_port' on the next rising edge of the clock. 'read_strobe' is only used by peripheral logic when it needs to know that data has been read e.g. when reading a FIFO.
port_id[7:0]	Output	This value defines which output port KCPSM6 intends to write data to during 'OUTPUT' and 'OUTPUTK' instructions or which input port in wants to read from during an 'INPUT' instruction. During an 'OUTPUTK' instruction only the lower 4-bits (port_id[3:0]) are valid and allow the definition of 16 constant-optimised ports qualified by 'k_write_strobe'. During 'INPUT' and 'OUTPUT' instructions all 8-bits are valid supporting up to 256 output ports qualified by 'write_strobe' and up to 256 input ports with 'read_strobe' available when required.

KCPSM6 Generics

Please note that the Verilog equivalent of each file is also provided.

KCPSM6 has three generics that can be adjusted if required.

```
processor: kcpsm6
  generic map (
    hwbuild => X"41",
    interrupt_vector => X"F80",
    scratch_pad_memory_size => 256)
  port map(
    address => address,
    instruction => instruction,
    bram_enable => bram_enable,
    port_id => port_id,
    write_strobe => write_strobe,
    k_write_strobe => k_write_strobe,
    out_port => out_port,
    read_strobe => read_strobe,
    in_port => in_port,
    interrupt => interrupt,
    interrupt_ack => interrupt_ack,
    sleep => kcpsm6_sleep,
    reset => kcpsm6_reset,
    clk => clk );
```

Component Instantiation showing changes to the default settings

```
hwbuild => X"41",
```

'hwbuild' can be used to define any 8-bit value in the range '00' to 'FF'. It is then possible to load any KCPSM6 register with this value using the 'HWBUILD sX' instruction (see page 101 for more details).

```
interrupt_vector => X"F80",
```

When an interrupt occurs (and interrupts are enabled) then KCPSM6 inserts and executes a special form of CALL instruction to a fixed address known as the interrupt vector (see page 42 for more details). The default this is address for the interrupt vector is '3FF' (the last location of a 1K program memory). Use this generic to adjust the address of the interrupt vector when larger program memories are used as well as to arrange that the vector correspond with the start of the actual interrupt service routine (ISR) eliminating a JUMP instruction.

```
scratch_pad_memory_size => 256)
```

The default size of the scratch pad memory is 64 bytes ('00' to '3F') but this generic can be used to increase it to 128 bytes ('00' to '7F') or 256 bytes ('00' to 'FF'). These will also increase the size of the KCPSM6 macro by 2 and 6 slices respectively (i.e. Maximum size of KCPSM6 will be 32 Slices). See pages 81 and 82 for more details about the STORE and FETCH instructions.

RESET

Following device configuration KCPSM6 generates an internal reset to ensure predictable a reliable operation. The 'reset' input can then be driven High at any time during operation to force a restart (e.g. When the 'rdl' signal from JTAG Loader is asserted).

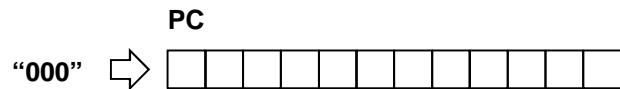

Program counter (PC) is forced to address '000' ready to fetch and execute the instruction located in the first location of the program memory.

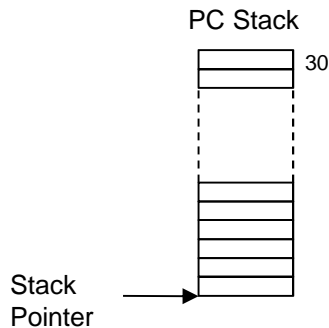
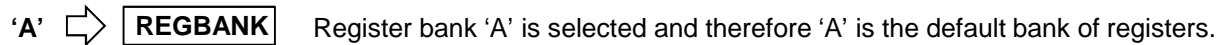
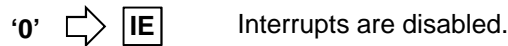
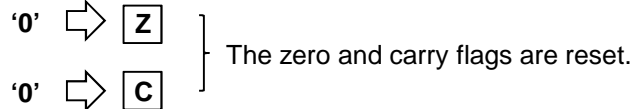

The pointer in the program counter stack is reset to ensure that the program is able to execute programs in which up to 30 nested subroutine calls can be made.

Note – If you should inadvertently write a program whose execution results in stack overflow or stack underflow then KCPSM6 will automatically generate an internal reset.

Hint– Following device power up and configuration the contents of all registers and scratch pad memory locations will be zero. Any subsequent reset will perform all the items shown above but registers and scratch pad memory will retain the values. This can be useful in certain application but your code should not rely of values being zero if manual reset is to be used during operation.

RESET

Power up reset and fundamental operation

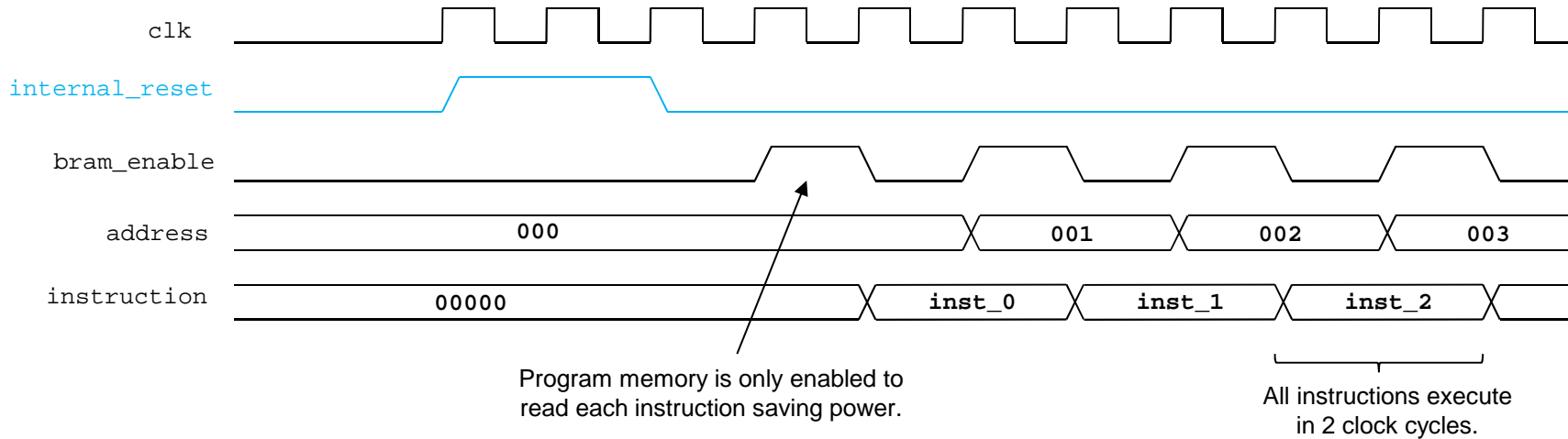

Operational Reset

Your reset pulse must be observed by at least one rising edge of the clock.

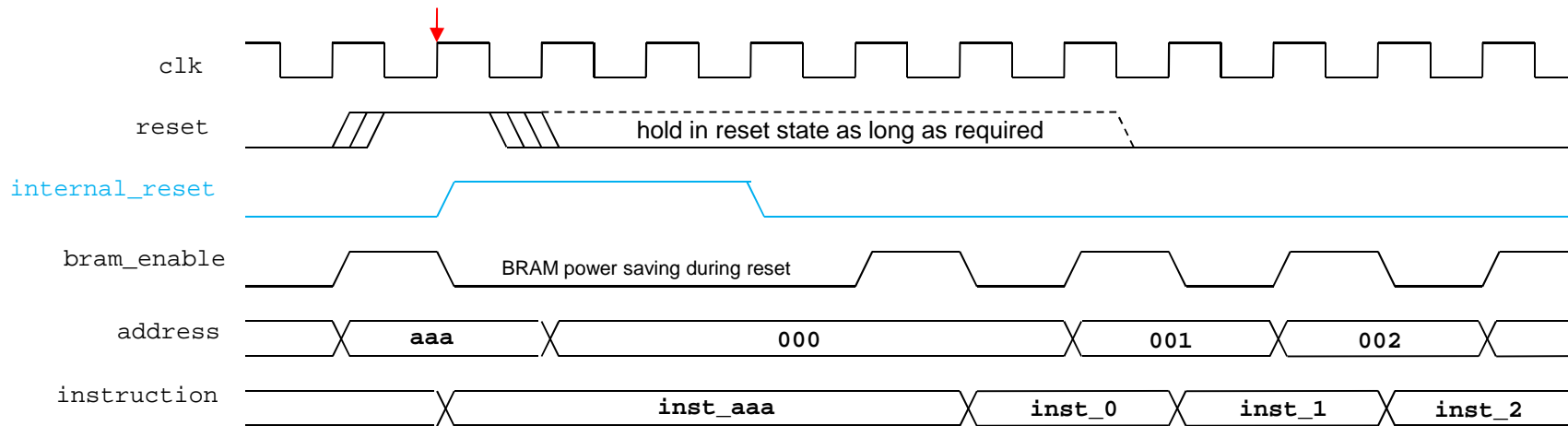

SLEEP

When the 'sleep' input is driven High, KCPSM6 will complete execution of the last instruction that has been read from the program memory and then freeze all operations. This ensures that the outputs from KCPSM6 are static with all the strobe signals inactive (Low). When the 'sleep' input is returned Low, KCPSM6 will wake up and resume from the point at which it stopped.

There are three fundamental use models for the 'sleep' control and your own circuit will control the 'sleep' input accordingly. Of course there is nothing to prevent combinations of these through appropriate control.

Maximum Power Reduction - Total power consumption is a combination of static power and dynamic power. When the 'sleep' control is active there is no dynamic switching occurring within KCPSM6 and hence the dynamic power consumption of KCPSM6 becomes zero. In addition, the 'bram_enable' is permanently driven Low by KCPSM6 whilst in the sleep state. This reduces the static power consumption of the BRAM(s) used to implement the program ROM virtually to zero.

It should be noted that although KCPSM6 will respond to a reset when in the sleep mode it will not react to an interrupt. If you would like KCPSM6 to wake up when an interrupt occurs then your control circuit should drive 'sleep' Low when it drives 'interrupt' High. In this situation KCPSM6 will wake up and immediately respond to the interrupt (assuming interrupts have been enabled by the previously executed PSM code) .

Performance Matching - KCPSM6 is typically supplied with a 'system clock' which leads to simple and reliable synchronous interfacing of the input and output ports to the other circuits being monitored and controlled within the system. However, it is also typical for KCPSM6 to be used to implement relatively slow functions for which the MIPS associated with the system clock frequency divided by 2 are excessive. Driving the 'sleep' input with a simple repeating waveform can force KCPSM6 to continuously alternate between sleep and awake modes. The duty factor of the waveform defining the relative reduction in the MIPS available with a corresponding reduction in average power consumption. In some applications it may be suitable to 'single step' the program execution whilst in others it may be more appropriate to wake KCPSM6 up occasionally for bursts of intense activity.

System Handshake - In this case 'sleep' can be considered to be a special case of a very simple non-maskable interrupt. It may also have the potential to reduce power consumption but this would not be the primary motivation. It provides the system with a way to make KCPSM6 wait for some reason. One example would be where KCPSM6 is writing information to a FIFO. Whenever the FIFO is at risk of overflowing the 'sleep' control could then be asserted to allow the FIFO some time to empty. In another example KCPSM6 may read and process information contained in a memory and the system could make KCPSM6 wait whilst that information was in the process of being changed.

System Debugging - By generally holding the 'sleep' input High it can then be pulsed Low for one clock cycle at a time to force KCPSM6 to single step through the program one instruction at a time. This can be a useful mechanism for system debugging. Note that one instruction 'step' will always be over a period of 2 clock cycles and this ensures that strobes will always be single clock cycle pulses.

SLEEP

When the 'sleep' input is driven High, KCPSM6 executes the instruction that has just been fetched from the program ROM and then enters sleep mode. Everything stops with all strobes Low and BRAM disabled for minimum power consumption. All inputs except for 'reset' are ignored whilst in sleep mode. When 'sleep' is returned Low there is a 2 clock cycle latency whilst KCPSM6 wakes up and reads the next instruction to resume execution from the point that it stopped.

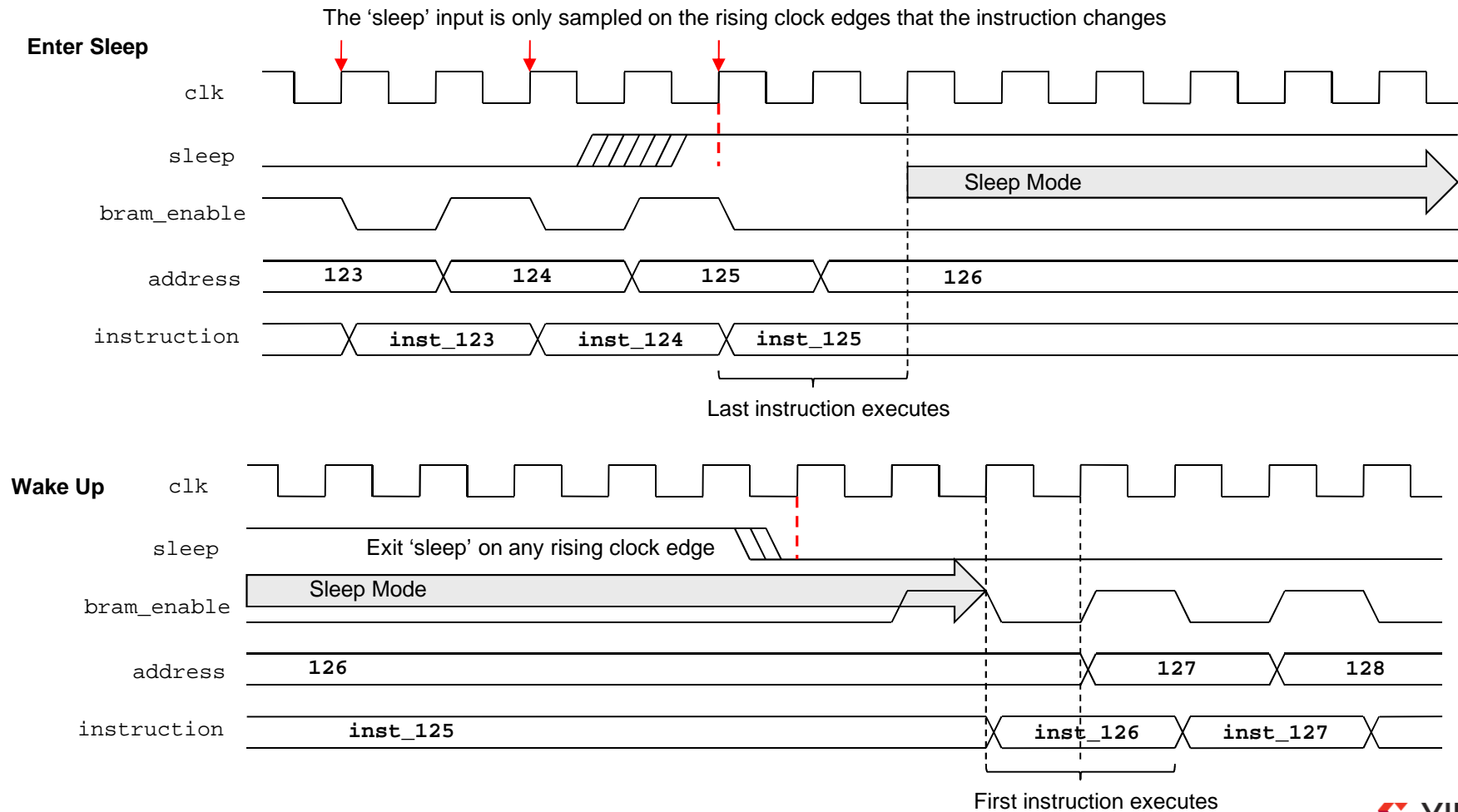

SLEEP

Once in sleep mode it is possible to execute the program one instruction at a time simply by pulsing the 'sleep' input Low for one clock cycle. This could be used as a system debugging mechanism or just as a way of slowing KCPSM6 down to better match the required performance of an application and save power.

Single Stepping

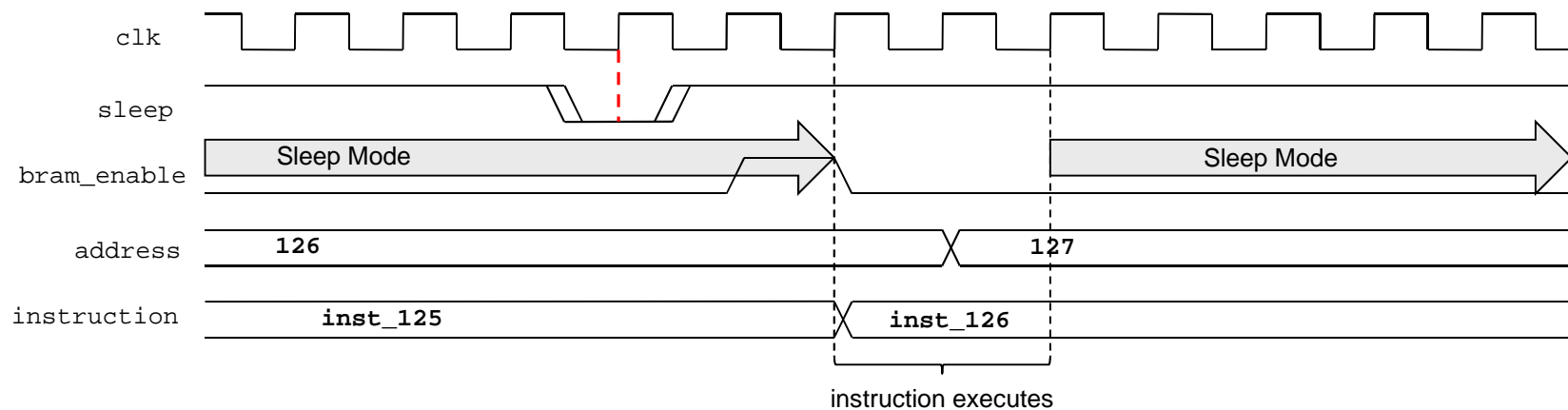

Slow Down Waveforms

Driving 'sleep' with a '110' waveform (shown below) will make KCPSM6 sleep for one clock cycle after the execution of each instruction that takes 2 clock cycles. Obviously this is the smallest amount KCPSM6 can be slowed down. The important observation is that all KCPSM6 operations remain fully synchronous with the clock, e.g. a 'write_strobe' will still only be a single cycle pulse ensuring that an OUTPUT instruction only writes once to logic.

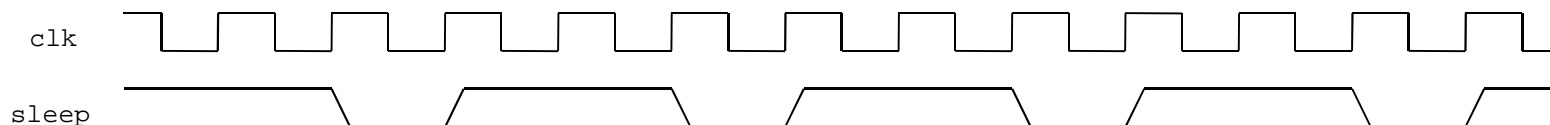

Likewise, driving 'sleep' with a '1110' waveform will make KCPSM6 sleep for two clock cycles after executing each instruction resulting in KCPSM6 running at half its normal speed. Hence KCPSM6 can be slowed down to any speed required using the appropriate 'sleep' waveform.

Interrupts

Interrupts can be extremely useful so KCPSM6 provides an 'interrupt' input pin, an 'interrupt_ack' output pin, an optional 'interrupt_vector' generic and three interrupt related instructions. However, it would be fair to say that interrupts are quite an advanced technique and require understanding, thought and preparation to be used wisely and successfully. This subject is made more interesting because each KCPSM6 is fully embedded into your FPGA design meaning that you have the option to define hardware dedicated to servicing tasks in a way that simply isn't available when using a standard microcontroller device. In fact, many PicoBlaze users have discovered that because each PicoBlaze is so small and efficient, it is often beneficial to use multiple instances within the same design in order that each is dedicated to a particular task and therefore avoiding the requirements for interrupts altogether. So it is well worth considering what an interrupt actually does and when it provides greatest benefit in a KCPSM6 design.

What does an interrupt do?

To state the obvious, an interrupt is used to interrupt the normal program execution sequence of KCPSM6. This means that when the 'interrupt' input is driven High ('1'), it will force KCPSM6 to abandon the code that it is executing, save its current operational state and divert its attention to executing a special section of program code known as an Interrupt Service Routine (ISR). Once the interrupt has been serviced, KCPSM6 returns to the program at the point from which it was interrupted and restores the operational states so that it can resume execution of the program as if nothing had happened.

Hence the interrupt mechanism provides a way for KCPSM6 to react to an event at any time and quite independently to the main tasks being performed. In other words an interrupt is given the highest priority which can be very useful particularly when reacting to a critical situation. However, it must also be recognised that in giving priority to one task all other tasks can be interrupted and hence their execution rates can be erratic or delayed.

When do interrupts make sense?

The key observation is that an interrupt has the highest priority. So clearly the most obvious application for an interrupt is to react quickly to system critical or emergency situations. These may be such rare events that they may never happen in normal operation such as the detection of a fire and the need to activate the water sprinklers. More common situations are less of an emergency but important to system integrity with a good example being the requirement to react to a FIFO buffer becoming full so that data is read from it before it actually overflows and data is lost.

Another application involves a regular or semi-regular stream of interrupts to KCPSM6 which become a fundamental part of the way in which the program normally operates. For example a hardware counter could easily generate an interrupt every milli-second which KCPSM6 uses as the reference for an accurate real time clock. The main program possibly enabling that clock to be set, displayed and for controlling the times at which appliances must be turned on and off. Alternatively KCPSM6 may use each interrupt as the trigger to perform a sequence of tasks but do virtually nothing else whilst waiting.

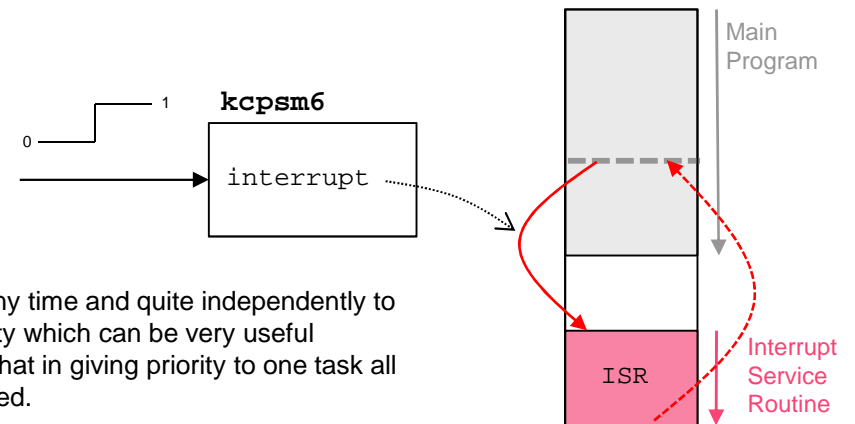

Interrupts

When are interrupts NOT suitable?

To answer this question there are two important observations. First is that whilst KCPSM6 is servicing an interrupt, it is not making any progress executing the main program (i.e. the main program has been interrupted!). Secondly, KCPSM6 can only service one interrupt at a time which means that if another interrupt occurs whilst KCPSM6 is busy executing the ISR then that new interrupt will either be missed or will have to wait neither of which is ideal. In general terms, an interrupt scheme is not suitable if the rate at which interrupts occur is too fast for them to be serviced and for the main program to make adequate progress. Clearly the definition of 'too fast' depends on how demanding both the main program and the ISR are but the one absolute constant is that every KCPSM6 instruction always takes 2 clock cycles to execute. So at least you can easily determine the code execution rate for a given clock frequency and compare that with the demands of your program and your expected interrupt rate.

For example, consider the use of interrupts generated at 1ms intervals for use as a time reference for a real time clock. With a KCPSM6 operating at a clock frequency of 66MHz it will execute 33,000,000 instructions per second and therefore it will be able to execute 33,000 instructions between each interrupt. This is clearly a large number and most unlikely to impede the ability to make good progress through any program whilst always being ready to service the next interrupt. But suppose the interrupts are generated at 1 μ s intervals with the aim of achieving finer timing resolution. Now KCPSM6 would only be able to execute 33 instructions between each interrupt (i.e. Less instructions that you can print out on one side of a piece of paper!). Unless the ISR is very brief it will not complete in time. Even if the ISR was only 12 instructions it would mean that over a third of the computing power was consumed servicing the simple ISR and that means that the main program would execute proportionally slower with an associated 'hesitancy' caused by the continuous interruptions. This may still be acceptable for the application but it is certainly on the verge of being unsuitable and will make it very difficult to expand the features implemented by the program code.

What are the alternatives?

When interrupts make sense then it is a very useful feature of KCPSM6 to exploit. However, when they are not suitable the benefit of using a Xilinx FPGA is that there are very good alternatives. The biggest mistake people often make is to battle with interrupt based solutions when they are not suitable. It is much better to exploit alternative solutions to make the overall design much easier to implement.

Increased use of hardware – Quite simply circuits are implemented which perform what would have been achieved by the software based ISR such that interrupts are avoided or their rate greatly reduced. For example a hardware based counter/timer block can be very simple to implement in hardware and then KCPSM6 can read time values from it when it needs to. The complexity of a real time clock could still be implemented in software but the timing resolution is best handled by the naturally fast hardware. Interrupts could then be used occasionally when a hardware comparator matches a time value set by KCPSM6.

Divide and conquer! – If a KCPSM6 processor is 100% dedicated to a task then really it is always performing an ISR. This makes sense if the ISR is relatively complex to consider implementing in hardware. With KCPSM6 being so small (26 Slices) dedicating a different processor to each demanding task can often be the easiest and best solution. Indeed, PicoBlaze is often used to service interrupts for a larger processor such as MicroBlaze.

'interrupt_vector' and 'ADDRESS' Directive

See pages 83-85 for interrupt related instructions

When KCPSM6 responds to an interrupt it executes the equivalent of a CALL instruction as well as the interrupt specific tasks such as preserving the states of the flags. The interrupt vector is the address that KCPSM6 effectively calls and it has the default value of 3FF hex. However, this can be set to any value within the range of the program memory available in your design using the 'interrupt_vector' generic in your HDL design description.

```
processor: kcpsm6
  generic map (
    hwbuid => X"00",
    interrupt_vector => X"3FF",
    scratch_pad_memory_size => 64)
  port map(
    address => address,
    instruction => instruction,
  Etc...
```

Component declaration (part of) showing the default values of the three generics.

Component Instantiation (part of) showing that the interrupt vector has been set to 'F80' hex.

```
processor: kcpsm6
  generic map (
    hwbuid => X"41",
    interrupt_vector => X"F80",
    scratch_pad_memory_size => 256)
  port map(
    address => address,
    instruction => instruction,
  Etc...
```

ADDRESS Directive

Use the ADDRESS directive in your PSM code to force the ISR to be assembled starting at the same address as the interrupt vector.

PSM file...

```
ADDRESS F80
;
ISR : ADD sF, 1'd
RETURNI ENABLE
```

What is a good address for 'interrupt_vector'?

3FF is the last location in a 1K program memory and is consistent with KCPSM, KCPSM-II and KCPSM3. So for direct compatibility with legacy PicoBlaze programs this is the best address to start with and hence the reason why it is the default. Of course you could modify the program and vector.

Generally the most convenient address is somewhere *close to the end* of the program memory available but leaving enough space for the ISR. This means that the ISR can begin servicing the interrupt immediately. It is also convenient from a programming perspective because the ADDRESS directive must be used to align the start of the ISR code with interrupt vector and having this as the last section of your PSM program allows your main program the flexibility to expand up to it. As your code becomes stable you can always fine tune your matching 'interrupt_vector' and ADDRESS directive for best memory fit.

What are bad values? If you try to put your ISR somewhere in the middle of your program then you will probably find that you are always having to adjust the ADDRESS directive and 'interrupt_vector' which is just an inconvenient waste of time as well as error prone. The absolute worst address would be zero! Under no circumstances would you want your ISR to execute on power up or following a reset (RETURNI should only be used following an interrupt).

Hardware arrangements for KCPSM6 Interrupt

See pages 83-85 for interrupt related instructions

The KCPSM6 processor has two pins dedicated to interrupts; an 'interrupt' input and an 'interrupt_ack' output. To initiate an interrupt the 'interrupt' input must be driven High and the fundamental interrupt response time is just 3 or 4 clock cycles. As shown on the next page (Interrupt Waveforms) the interrupt input is sampled once every two clock cycles consistent with the instruction execution rate. For this reason it is vital that the interrupt input is High at the right time to be observed by KCPSM6 and the easiest way to achieve that is to drive the interrupt input High for longer than one clock cycle. There are two fundamental schemes that can be used which can really be described as being 'open-loop' and 'closed loop'.

'Open-Loop' interrupt pulse

The simplest way of initiating an interrupt is to generate an active High pulse that has a duration of 2 clock cycles. The pulse can be longer but should have returned Low before the ISR completes otherwise KCPSM6 will immediately think there is another interrupt to service (remember that each instruction executes in 2 clock cycles so some ISR's may not take very many clock cycles). Once KCPSM6 observes the High level on its interrupt input it will abandon the next instruction and immediately move to the ISR.

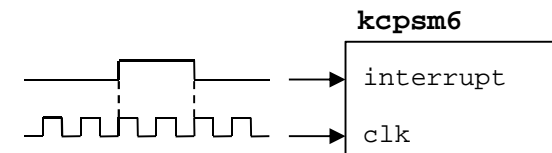

The simplicity of the 'open-loop' method is obvious but it must also be recognised that any open loop system has its limitations. In this case there is the potential for KCPSM6 to miss an interrupt request and therefore fail to service it. This could happen if the KCPSM6 program has deliberately disabled interrupts or is already servicing a previous ISR. KCPSM6 will also ignore the interrupt input whilst held in sleep mode. Therefore this technique should only be used if you can predict that KCPSM6 will always be ready to respond to an interrupt request or if it is acceptable for interrupts to be missed.

'Closed-Loop' interrupt (recommended)

In this scheme your design drives the interrupt signal High to request an interrupt and then keeps driving it High until KCPSM6 generates an 'interrupt_ack' pulse confirming that it has seen it. This ensures that the interrupt will always be observed by KCPSM6 when it is able to. If interrupts have been temporarily disabled deliberately, or whilst servicing a previous interrupt, then the response will be delayed but the event can not be missed. Likewise, if KCPSM6 is held in sleep mode when the interrupt is requested it will remain active until KCPSM6 is allowed to wake up and observe it.

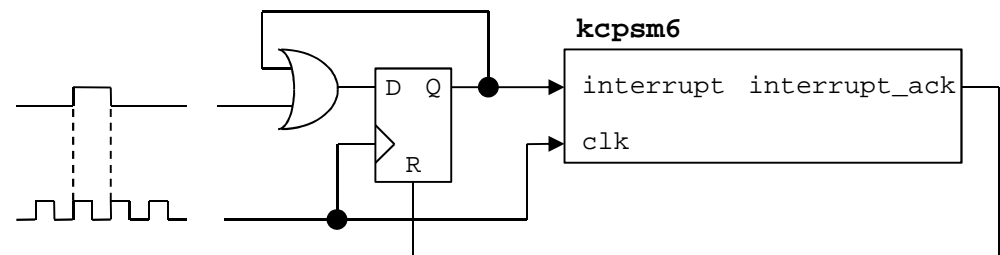

Hint – Some systems can require a more comprehensive closed-loop arrangement in which KCPSM6 would be expected to indicate when the ISR has completed rather than just started (which is what 'interrupt_ack' signifies). This can be achieved using an output port with associated 'OUTPUT' or 'OUTPUTK' instructions at the end of your ISR. Alternatively you could detect when instruction[17:12] = "101001" corresponding with the 'RETURN!' instruction being fetched from the program memory.

Interrupt Waveforms

See pages 83-85 for interrupt related instructions

An interrupt is performed when the 'interrupt' input is driven High, interrupts have been enabled by the program and KCPSM6 is not in sleep mode or otherwise busy servicing a previous interrupt. When KCPSM6 detects an interrupt it forces the next instruction to be abandoned, preserves the current states of the 'Z' and 'C' flags, notes the current bank selection ('A' or 'B') and then forces the program counter to the interrupt vector (default value is 3FF hex which is the last location of a 1K program memory but can be set to any value using the 'interrupt_vector' generic).

The waveforms shown below illustrate a normal response to an interrupt when interrupts have been enabled within the program and KCPSM6 is ready to respond. In the hardware design the interrupt vector was set to FF0 hex and a 'closed-loop' interrupt scheme used (implemented by the VHDL shown on the right) to ensure that the interrupt pulse can not be missed.

```

interrupt_control: process(clk)
begin
  if clk'event and clk = '1' then
    if interrupt_ack = '1' then
      interrupt <= '0';
    else
      if kcpsm6_interrupt = '1' then
        interrupt <= '1';
      else
        interrupt <= interrupt;
      end if;
    end if;
  end if;
end process interrupt_control;

```

```

interrupt_vector => X"FF0",

```

The 'interrupt' input is sampled on the rising clock edges that the address

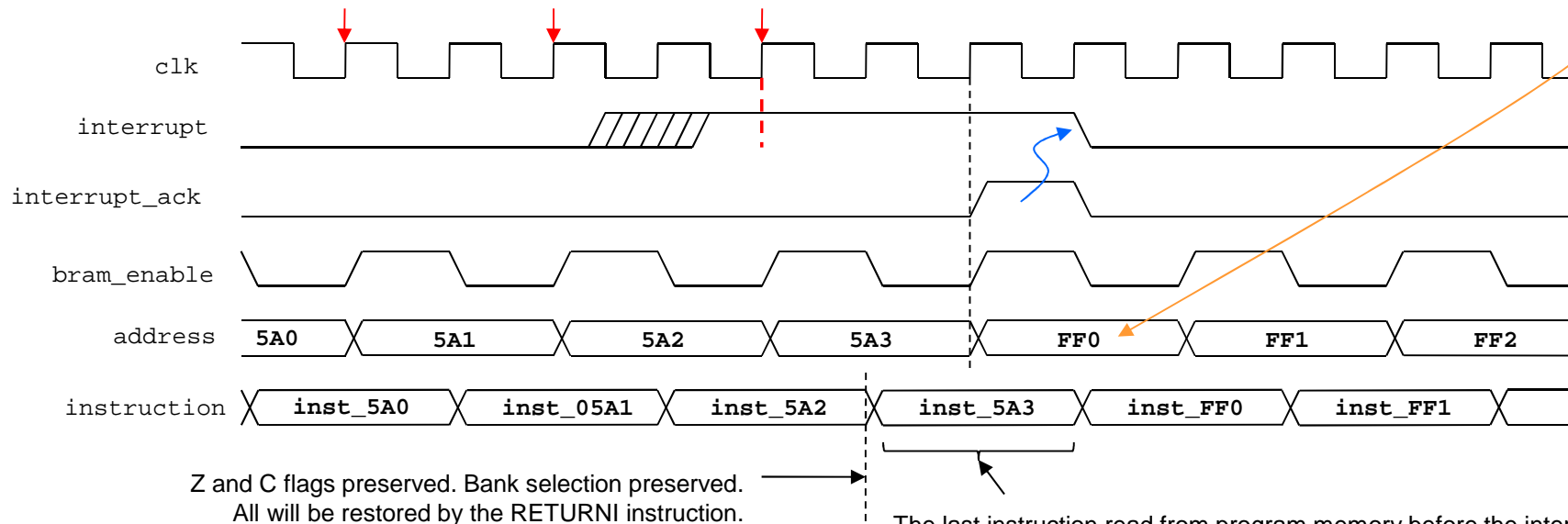

Z and C flags preserved. Bank selection preserved.
All will be restored by the RETURNI instruction.

The last instruction read from program memory before the interrupt takes place is abandoned. This will be the first instruction executed following a RETURNI after the interrupt has been serviced.

HDL Simulation Features

Hint – In most of the cases in which a user reports that KCPSM6 does not simulate at all (e.g. the 'address' does not advance as expected), the cause has been the failure on the part of the user to define valid logic levels for the 'interrupt', 'sleep' and 'reset' controls. So please make sure that all signals are defined at the start of your simulation either in your design or in your simulation test bench.

Since KCPSM6 is a fully embedded part of your hardware design it will simulate along with the rest of your design in an HDL simulator such as iSim or XSim. This means that you can see how KCPSM6 interacts with your design in the same fundamental way in which you might check the operation of a dedicated state machine.

As well as being able to observe any of the input and output signals connecting KCPSM6 to the rest of your design KCPSM6 contains some additional signals specifically for simulation purposes only.

Within the simulator locate the instance of KCPSM6 to be observed. In this case the instance name is 'processor' and the simulator is iSIM (part of ISE).

Then all the internal signals of KCPSM6 can be seen and selected for waveform display as desired. Look down the list and the simulation specific signals can be found.

kcpsm6_opcode – This is a text string displaying the instruction being executed. As well as being easier to understand than the raw codes being read from the program memory they can also be compared with the LOG file from the assembler to directly trace code execution

kcpsm6_status – This is a text string displaying the status...
 Active register bank 'A' or 'B'
 Zero flag Z or NZ
 Carry flag C or NC
 Interrupts enabled (IE) or disabled (ID)
 Reset or Sleep modes.

e.g. A, Z, NC, IE, Sleep
 Bank A, Z=1, C=0, interrupts enabled, in sleep mode

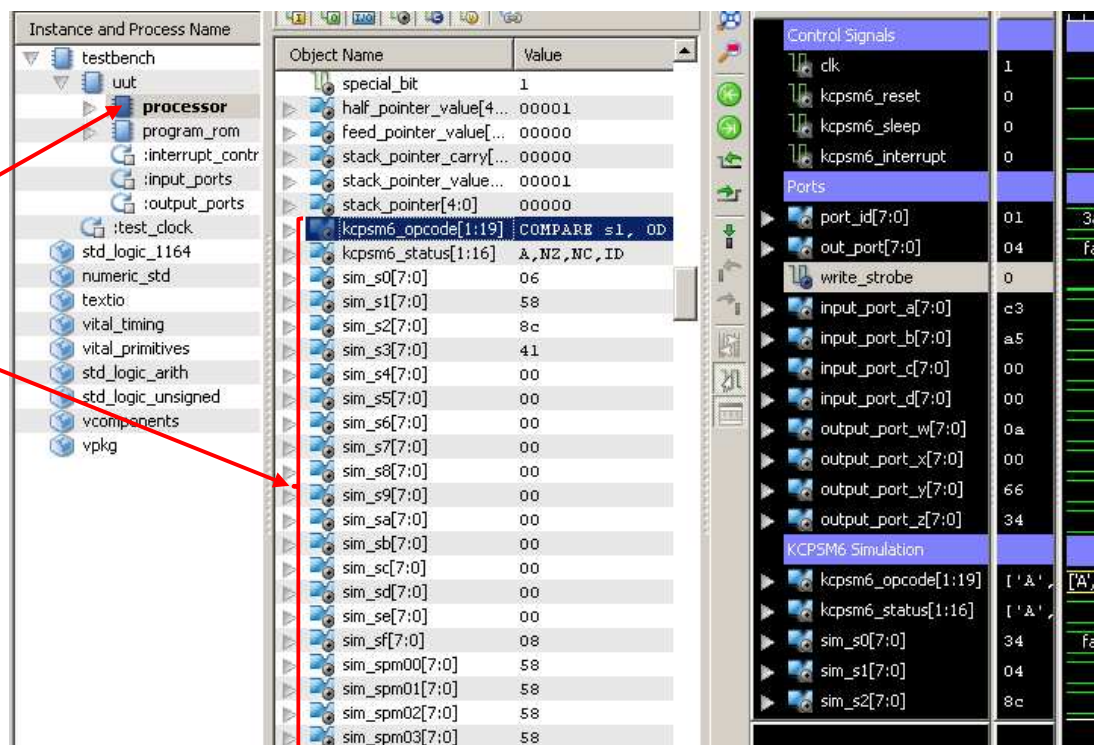

'sim_s0' to 'sim_sf' – The contents of each of the 16 registers in the active register bank (i.e. Contents will reflect bank selection).

'sim_spm00' to 'sim_spmff' – The contents of each of the 256 scratch pad memory locations. Remember that default memory size is 64 bytes (only up to sim_spm3f).

Hint – Adjust the radix of the values displayed.

HDL Simulation Features

In this iSim or Xsim waveform view the following can be seen...

Each instruction taking 2 clock cycles to execute

Instruction op-codes decoded and displayed as text strings.

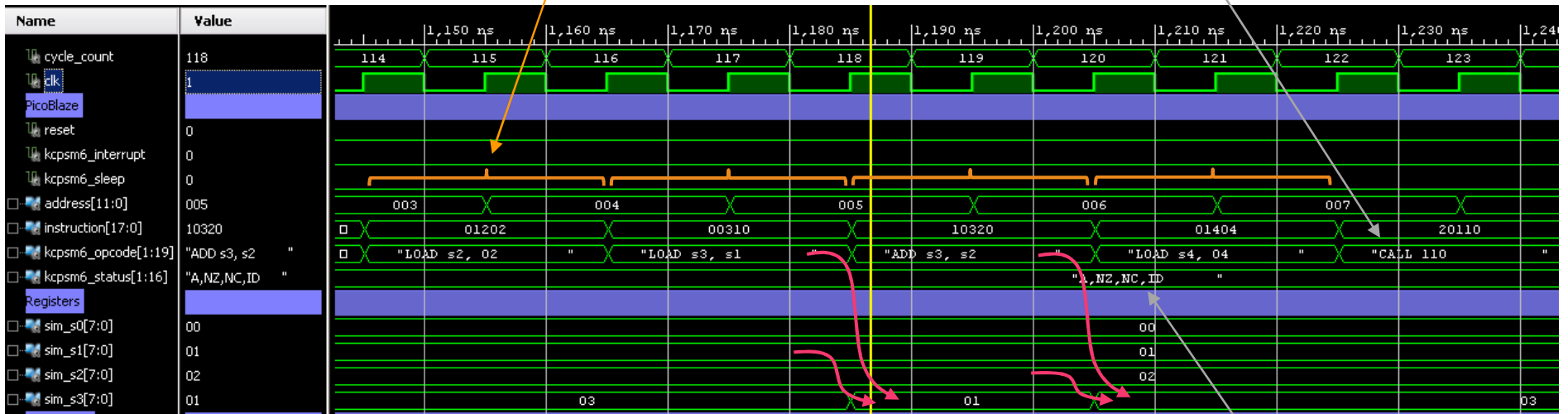

The contents of registers. In this example we can see 's3' being loaded with the contents of 's1' followed by the addition of the contents of 's2'.

Register bank 'A', States of flags and interrupt.

Hint – KCPMS6 programs often contain code that is used to deliberately slow down the progress through the program to service the application correctly either using software delay loops or polling of status signals. For example, when communicating with a UART that has a BAUD rate of 115200 then each character will take 86.8µms to be received and that would equate to 8,680 clock cycles of a 100MHz system clock. Due to this, it is not uncommon for users to become confused by what they perceive as a “lack of activity” in their simulated design simply because KCPMS6 is taking so many clock cycles. So if this is the situation, it may be necessary to alter the PSM code to make the HDL simulation practical but obviously you will need to remember to restore the correct code for the real application. In practice, most PSM code is developed interactively in real-time on the target hardware using JTAG_Loader to facilitate rapid iterations. As such, HDL simulation is best used to confirm your port interfacing logic and generation of particular strobes and waveforms etc.

Production Program Memory (ROM_form)

Please note that the Verilog equivalent of each file is also provided.

During the design and code development phase the default 'ROM_form' template is used with the assembler. This generates the hardware definition of the program memory and the three generics make it easy to specify the target family (Spartan-6, Virtex-6 or 7-Series), adjust the size of the memory and include the JTAG Loader which you almost certainly found to be an invaluable tool. Whilst such flexibility and the JTAG Loader are extremely useful tools during development it does mean that the program memory definition file generated by the assembler is somewhat large and over complicated for a production release. The JTAG Loader may well have been an invaluable tool during development but leaving your KCPSM6 program open to adjustment in a production product could present a threat to design security. Of course you may decide to exploit the JTAG Loader utility as part of your production product too in which case just leave everything as it is!

In order that you can go into production with the most simplified hardware definition of your program memory and ensure that JTAG Loader is not accidentally enabled a set of 'production' templates are provided. The name of each production template describes the target family ('S6' for Spartan-6, 'V6' for Virtex-6 and '7S' for 7-Series) and the size of the program memory implemented (1K, 2K or 4K instructions). There is also one special case that replaces the BRAM completely with 18-Slices of distributed ROM and provides a very efficient implementation for programs up to 256 instructions. Make a copy the appropriate file and rename it 'ROM_form.vhd'. Then use this file with the assembler and your PSM file to generate the simplified memory definition.

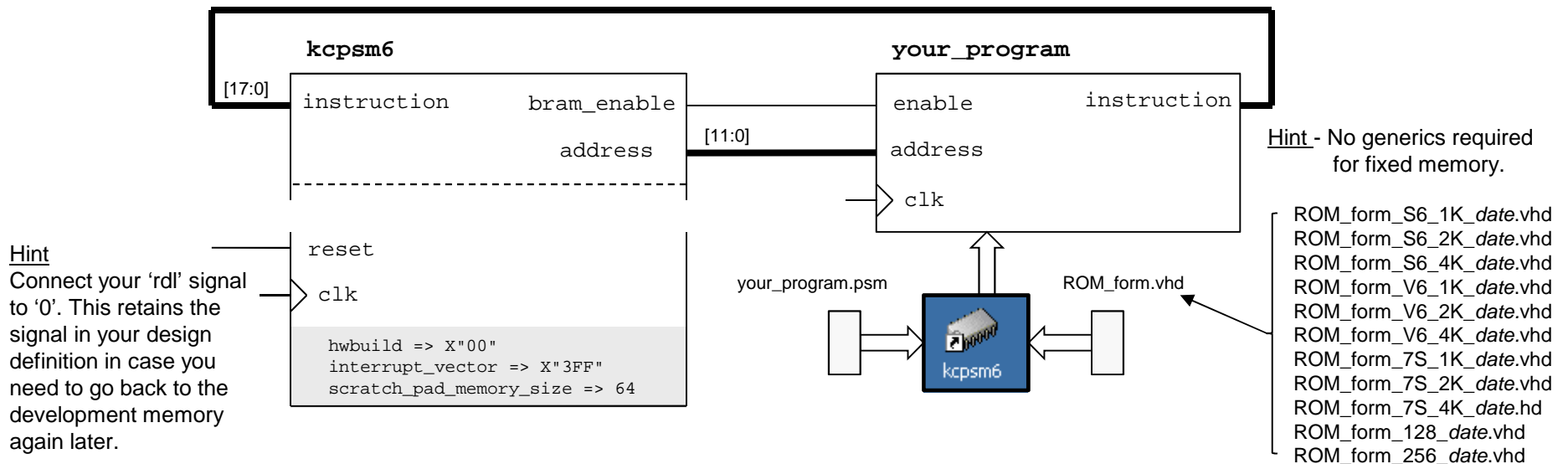

Hint - The default 'ROM_form.vhd' is a renamed copy of the file called 'ROM_form_JTAGLoader_14March13.vhd' which is also provided in the KCPSM6 package.

Hint - A 'ROM_form' template is a standard HDL file except that it contains special {tags} that the assembler intercepts. You can modify any of the templates provided to define your own special format of program memory (e.g. a dual port memory in which the program can be changed by a different mechanism to JTAG Loader).

PSM Software Reference

The following information provides more detailed descriptions of the KCPSM6 assembler and PSM syntax. Where necessary additional descriptions are provided to give the context in which groups of instructions are used.

Hint - The descriptions for each of the instructions contain examples of PSM code. So please do not dwell too long on the formal but brief descriptions of assembler syntax because most of this should become clear through the examples and become natural to you once you start writing your own code and the assembler starts providing you with feedback.

To complement this documentation the following additional reference material is provided in the KCPSM6 package (ZIP file)...

`all_kcpsm6_syntax.psm` – This Provides a PSM file (albeit not a real program) in which there are examples of all the PSM syntax supported by the KCPSM6 assembler.

Hint – As well as the examples, ‘`all_kcpsm6_syntax.psm`’ contains more comprehensive descriptions of the assembler syntax than contained in this document. In contrast, this document is more focused on describing the actual KCPSM6 instruction set.

`kcpsm6_assembler_readme.txt` – This document will have more appeal to the advanced user, particularly those that would prefer to invoke the assembler as part of a batch flow. As such, this document is rather clinical and factual!

Hint – This file does document any known issues and limitations but hopefully you won’t encounter them.

UART sub-directory – This directory includes a simple but fully documented design in which KCPSM6 is connected to UART macros. As well as the hardware design the PSM program (‘`uart_control.psm`’) provides multiple examples including ASCII hexadecimal to decimal conversion routines with numerous comments.

The KCPSM6 Assembler

The KCPSM6 Assembler is provided as a single executable file 'kcpsm6.exe'. This can be placed anywhere in your system but in most cases it is just easier and more convenient if you place a copy in the working directory of your ISE project (it is only 109k-bytes) .

```
kcpsm6.exe
KCPSM6 Assembler v2.46
Ken Chapman - Xilinx Ltd - 18th February 2013

Enter name of PSM file: uart_control.psm

Reading top level PSM file...
C:\Data\chapman\PicoBlaze_Designs\uart_control.psm

Including PSM files...
C:\Data\chapman\PicoBlaze_Designs\uart_interface_routines.psm

A total of 776 lines of PSM code have been read

Checking line labels
Checking CONSTANT directives
Checking STRING directives
Checking TABLE directives
Checking instructions

File: uart_control.psm
Path: C:\Data\chapman\PicoBlaze_Designs
Line: 338

JUMP send_mesage

ERROR - Invalid address: send_mesage
The target address should be specified by one of the following....
A hexadecimal address in the range '000' to 'FFF'
A decimal address in the range 0'd to 4095'd
A binary address in the range 000000000000'b to 111111111111'b
A (case sensitive) line label

KCPSM6 Options.....
R - Repeat assembly with 'uart_control.psm'
N - Assemble new file.
Q - Quit
```

In most cases, or at least to begin with, the interactive method is adequate. Simply double click on the executable and a window like this will open.

Type in the name of your top level PSM file (you don't have to put '.psm' on the end of the name but the file must have the '.psm' extension).

Hint – A text file called 'kcpsm6_assembler_readme.txt' contains additional information for those interested in invoking the assembler from batch files or using a 'drag and drop' method.

Hint – Should you encounter any unexpected issues using the assembler then please check the "Known Issues and Workarounds" section contained in the file called 'kcpsm6_assembler_readme.txt'.

The assembler will read your top level PSM file and include any PSM defined by INCLUDE directives. It will then check all your definitions and code for correct syntax.

If the assembler detects an error in your PSM code then the assembler it will identify the PSM file and the line in that file that it can not resolve and make suggestions for you to be able to rectify the issue.

You are then presented with 3 simple options. The 'R' option means that can quickly re-run the assembler as soon as you have used your chosen text editor to make appropriate modifications to your in your PSM file (and saved it). This makes very rapid iterations very easy.

The KCPSM6 Assembler

```
kcpsm6.exe
KCPSM6 Assembler v2.46
Ken Chapman - Xilinx Ltd - 18th February 2013

Enter name of PSM file: uart_control.psm

Reading top level PSM file...
  C:\Data\chapman\PicoBlaze_Designs\uart_control.psm

Including PSM files...
  C:\Data\chapman\PicoBlaze_Designs\uart_interface_routines.psm

A total of 776 lines of PSM code have been read

Checking line labels
Checking CONSTANT directives
Checking STRING directives
Checking TABLE directives
Checking instructions

Writing formatted PSM files...
  C:\Data\chapman\PicoBlaze_Designs\uart_control.fmt
  C:\Data\chapman\PicoBlaze_Designs\uart_interface_routines.fmt

Expanding text strings
Expanding tables
Resolving addresses and Assembling Instructions
  Last occupied address: 294 hex
  Nominal program memory size: 1K (1024)   address(9:0)
  Occupied memory locations: 661
  Assembly completed successfully

Writing LOG file...
  C:\Data\chapman\PicoBlaze_Designs\uart_control.log
Writing HEX file...
  C:\Data\chapman\PicoBlaze_Designs\uart_control.hex
Writing VHDL file...
  C:\Data\chapman\PicoBlaze_Designs\uart_control.vhd

KCPSM6 Options.....
  R - Repeat assembly with 'uart_control.psm'
  N - Assemble new file.
  Q - Quit
```

Providing your PSM file contains valid syntax then the assembler will generate a perfectly formatted version of your original program that you can adopt to make it look like you have been working hard all day making something look that nice ☺. See example on page 23. As shown in this example, when INCLUDE directives are used then a formatted file will be generated corresponding with each source PSM file.

Then as long as your program can fit into the available address range (default is 4K but you may like to use the '-c' option when invoking the assembler to specify a smaller memory), the assembler will tell you the last occupied address and indicate the nominal size of program memory required. This is where you may need to review your code and adjust any ADDRESS directives so that your program will fit within a smaller program memory.

Following a successful assembly, a LOG file and a HEX file will always be generated. The log file provides you with a detailed report showing how your PSM file has been interpreted and the addresses and op-codes assigned to each instruction (see next page). The HEX file is a simple hexadecimal list of the 4096 op-codes defined by your program (all undefined locations are zero) and this is primarily for use with the JTAG Loader utility during development.

Finally the assembler has the ability to generate a VHDL or Verilog file that defines the program memory you need to synthesise your hardware design. The VHDL or Verilog file describes the BRAMs pre-initialised with your program.

IMPORTANT – The assembler will only generate a VHDL or Verilog file when there is a corresponding 'ROM_form.vhd' or 'ROM_form.v' template provided in the same directory as your top level PSM file. If both templates are provided then both VHDL and Verilog files will be generated.

Hint – The default 'ROM_form.vhd' is a renamed copy of the file called 'ROM_form_JTAGLoader_14March13.vhd' also provided in ZIP file.

The Assembler Log File (‘.log’)

This ‘LOG’ file should not be something you need to look at very often but it can be useful reference when you are debugging a system or your code especially when you are analyzing the interaction with the hardware design in an HDL simulator or in real hardware with ChipScope etc.

```
Assembly datestamp: 19 Apr 2012
Assembly timestamp: 16:02:20
```

This file begins with a header includes a time and date stamp to help you keep track of your code iterations and know what program you are using

The main part of the log file shows your program and the addresses and op-codes for each instruction.

```
Addr Code      Instruction
000           ;
000           ; Simple example
000           ;
000           CONSTANT A_port, 00           ;Input ports
000           CONSTANT B_port, 01
000           CONSTANT C_port, 02
000           CONSTANT D_port, 03
000           CONSTANT W_port, 01           ;Output ports
000           CONSTANT X_port, 02
000           CONSTANT Y_port, 04
000           CONSTANT Z_port, 08
000           ;
000           NAMEREG sF, counter
000 09000      start: INPUT s0, 00[A_port]      ; read port A
001 0D001      TEST s0, 01                    ;test value of LSB
002 32005      JUMP Z, 005[count_up]
003 19F01      SUB sF[counter], 01[1'd]      ;count down
004 22006      JUMP 006[update_X]
005 11F01      count_up: ADD sF[counter], 01[1'd] ;count up
006 2DF02      update_X: OUTPUT sF[counter], 02[X_port]
007 09201      INPUT s2, 01[B_port]          ; Z = B AND C
008 09302      INPUT s3, 02[C_port]
009 02230      AND s2, s3
00A 2D208      OUTPUT s2, 08[Z_port]
00B 22000      JUMP 000[start]
```

This PSM code is suitable for the hardware shown on page 72.

Each time the assembler has resolved the value of an operand the way in which you originally defined that operand is displayed in square brackets for reference. For example...

```
OUTPUT sF[counter], 02[X_port]
```

The register ‘sF’ was defined by the name ‘counter’ and the port_id address ‘02’ was defined by the CONSTANT directive ‘X_port’.

After the program assembly listing is followed by lists of all the constants, tables, strings and line labels defined in your program or by the assembler.

These lists can be particularly useful when confirming your allocation of ports with your hardware design.

Although not shown in this example, the lists also identify the PSM file in which item was defined. This helps when INCLUDE directives are used.

CONSTANT name	Value
timestamp_hours	16'd
timestamp_minutes	16'd
timestamp_seconds	54'd
datestamp_year	12'd
datestamp_month	4'd
datestamp_day	19'd
A_port	00
B_port	01
C_port	02
D_port	03
W_port	01
X_port	02
Y_port	04
Z_port	08

No TABLEs defined

List of text strings

STRING name	String
KCPSM6_version\$	"v2.00"
datestamp\$	"19 Apr 2012"
timestamp\$	"16:16:54"

Hint – The ‘datestamp’ and ‘timestamp’ constants and strings, along with HWBUILD, provide everything you need to implement a version reporting scheme for production units as well as keeping track throughout development.

PSM Syntax

Each line of your PSM file should adhere to the following basic syntax. Don't worry too much about getting everything perfect or tidy because the assembler will look after things like additional spaces and is very tolerant of upper or lower case characters except where it really matters. If you get something wrong the assembler will show you what it doesn't like and provide advice to help you correct it. KCPSM6 writes out a nicely formatted FMT file for you to adopt.

label: instruction operand1, operand2 ; comment

Any line can be given a label that will eventually be associated with an address. When a label is defined it must be followed by a colon ':'. A label is case sensitive and can be any number of the standard characters 'a' to 'z', 'A' to 'Z', '0' to '9' and '_' (underscore) but it should not be a name that could be confused with a hex value.

A label can then be used anywhere in the program to define the target address for a JUMP or CALL instruction as well as with the 'lower' and 'upper' attributes to define constants for use in other instructions.

Any of the KCPSM6 instructions or an assembler directive. Upper or lower case accepted.

All instructions and directives except RETURN have at least one operand and this should be separated from the instruction by at least one space.

Instructions and directives that require a second operand should be separated from the first operand by a comma ',' (any spaces are formatting).

Anything following a semicolon ';' will be treated as a comment and otherwise ignored by the assembler.

Default register names are represented by 'sX' or 'sY' and can be any of the following... 's0', 's1', 's2', 's3', 's4', 's5', 's6', 's7', 's8', 's9', 'sA', 'sB', 'sC', 'sD', 'sE', 'sF'.
The assembler will accept upper and lower case, e.g. 'sb', 'SB' and 'Sb' are also 'sB'.

Constant values are represented by 'aaa', 'kk', 'ss', 'p' and 'pp'.
Each character represents the requirement for a hexadecimal digit to define an address, constant or port. So for example 'kk' is any value in the range '00' to 'FF' hex.
Hex values are the default and can be specified in upper or lower case, e.g. '6d' or '6D'.
Decimal and binary values can be defined using 'd' and 'b' attributes
e.g. 109'd and 01101101'b are both equivalent to '6D' hex.

Also for 'kk' constants only...

The ASCII equivalent of a character can be assigned, e.g. "n" is the same as '6D'

The lower 8-bits of an address can be identified using label'lower.

The upper 4-bits of an address can be identified using label'upper (msb 4-bits will be zero).

Hint - The assembler ignores empty lines so use an empty comment (just a semicolon) to preserve a blank line in the FMT and LOG files.

Lines only containing comments will be formatted in-line with the instructions. Comments on lines containing an instruction will be formatted in a column to the right of the longest instruction. Looks nice ☺

Assembler directives follow the same basic syntax but are only used to direct the assembler and make code easier to write and understand.

```
INCLUDE "file.psm" / CONSTANT name, kk / ADDRESS aaa / NAMEREG oldname, newname / STRING name$, "text" / TABLE name#, [kk,kk,kk,..] / INST hhhh  
DEFAULT_JUMP aaa
```

NOTE – 'all_kcpsm6_syntax.psm' provides a PSM file (albeit not a real program) that further describes all directives and has examples of all the supported syntax. Since it is a valid PSM file you can assemble it and then look at the FMT and LOG files that KCPSM6 generates as well.

Registers and the NAMEREG Directive

KCPSM6 can generally access 16 general purpose registers assigned the default names 's0' through to 'sF'. There are absolutely no restrictions on which register or combination of registers can be specified as 'sX' or 'sY' operands in any of the instructions that work with registers. This provides you with complete freedom to allocate registers as you wish. If you are careful with your allocation of registers to different tasks it will often avoid the requirement to 'shuffle' data around too much which is often the case when a processor has an accumulator based processor architecture.

The KCPSM6 assembler is able to identify the default name of a register regardless of the mixture of upper and lower case characters that you use to describe it but it will always convert it to the lower case 's' followed by an upper case hexadecimal digit when writing the FMT and LOG files. For example 'S4' will be interpreted as the default register name 's4'. Likewise, 'sd', 'Sd' and 'SD' will all be interpreted as default register name 'sD'. In other words, the assembler allows you to concentrate on writing your code without having to be so precise about syntax and format.

NAMEREG Directive

The NAMEREG directive is an *optional* facility that can help you keep track of what data you expect a particular register to contain. Prior to the NAMEREG directive the register will have the default name such as 'sB'. Once renamed only the new name will identify the register and that name is case sensitive exactly as you defined it. Changing the name has no effect on the contents of the register or how it can be used.

```
ADD sB, 42
;
NAMEREG sB, Status
;
;
INPUT Status, flags_port
COMPARE Status, 12
;
NAMEREG Status, speed
;
SUB speed, 01
;
NAMEREG speed, sB
;
LOAD sB, 19
```

- } Default register name applies before the NAMEREG directive.
- } The new name can only contain 'a' to 'z', 'A' to 'Z' and '_' underscore (no spaces). It can be any length but must not be a name that could be confused for anything else like a line label of a hexadecimal value.
- } Following the NAMEREG directive only the new is valid and this name is case sensitive. In this case 'sB' will no longer be recognised.
- } The NAMEREG directive can be used to change the name again and then only the new name is valid in the following code. Depending on your way of thinking this is either useful or something to be avoided! ☺
- } The appropriate default register name can be restored and following this all the normal case insensitivity rules also apply.

16 Registers All general purpose All 8-bits

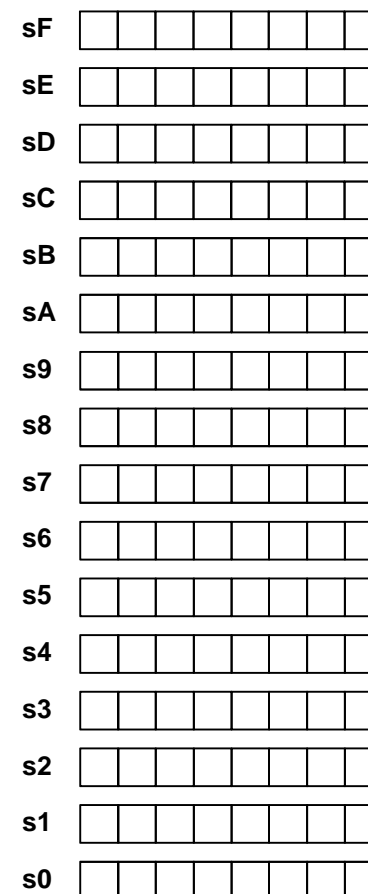

KCPSM6 Instruction Set

aaa : 12-bit address 000 to FFF
 kk : 8-bit constant 00 to FF
 pp : 8-bit port ID 00 to FF
 p : 4-bit port ID 0 to F
 ss : 8-bit scratch pad location 00 to FF
 x : Register within bank s0 to sF
 y : Register within bank s0 to sF

Page Opcode Instruction

Register loading

55 00xy0 LOAD sX, sY
 55 01xkk LOAD sX, kk
 71 16xy0 STAR sX, sY

Logical

56 02xy0 AND sX, sY
 56 03xkk AND sX, kk
 57 04xy0 OR sX, sY
 57 05xkk OR sX, kk
 58 06xy0 XOR sX, sY
 58 07xkk XOR sX, kk

Arithmetic

59 10xy0 ADD sX, sY
 59 11xkk ADD sX, kk
 60 12xy0 ADDCY sX, sY
 60 13xkk ADDCY sX, kk
 61 18xy0 SUB sX, sY
 61 19xkk SUB sX, kk
 62 1Axy0 SUBCY sX, sY
 62 1Bxkk SUBCY sX, kk

Test and Compare

63 0Cxy0 TEST sX, sY
 63 0Dxkk TEST sX, kk
 64 0Exy0 TESTCY sX, sY
 64 0Fykk TESTCY sX, kk
 65 1Cxy0 COMPARE sX, sY
 65 1Dxkk COMPARE sX, kk
 66 1Exy0 COMPARECY sX, sY
 66 1Fykk COMPARECY sX, kk

Page Opcode Instruction

Shift and Rotate

67 14x06 SL0 sX
 67 14x07 SL1 sX
 67 14x04 SLX sX
 67 14x00 SLA sX
 67 14x02 RL sX
 68 14x0E SR0 sX
 68 14x0F SR1 sX
 68 14x0A SRX sX
 68 14x08 SRA sX
 68 14x0C RR sX

Register Bank Selection

70 37000 REGBANK A
 70 37001 REGBANK B

Input and Output

73 08xy0 INPUT sX, (sY)
 73 09xpp INPUT sX, pp
 74 2Cxy0 OUTPUT sX, (sY)
 74 2Dxpp OUTPUT sX, pp
 78 2Bkpp OUTPUTK kk, p

Scratch Pad Memory

(64, 128 or 256 bytes)

81 2Exy0 STORE sX, (sY)
 81 2Fyss STORE sX, ss
 82 0Axy0 FETCH sX, (sY)
 82 0Bxss FETCH sX, ss

Page Opcode Instruction

Interrupt Handling

83 28000 DISABLE INTERRUPT
 83 28001 ENABLE INTERRUPT
 84 29000 RETURNI DISABLE
 84 29001 RETURNI ENABLE

Jump

87 22aaa JUMP aaa
 88 32aaa JUMP Z, aaa
 88 36aaa JUMP NZ, aaa
 88 3Aaaa JUMP C, aaa
 88 3Eaaa JUMP NC, aaa
 89 26xy0 JUMP@ (sX, sY)

Subroutines

92 20aaa CALL aaa
 93 30aaa CALL Z, aaa
 93 34aaa CALL NZ, aaa
 93 38aaa CALL C, aaa
 93 3Caaa CALL NC, aaa
 94 24xy0 CALL@ (sX, sY)
 96 25000 RETURN
 97 31000 RETURN Z
 97 35000 RETURN NZ
 97 39000 RETURN C
 97 3D000 RETURN NC
 98 21xkk LOAD&RETURN sX, kk

Version Control

101 14x80 HWBUILD sX

LOAD sX, kk

LOAD sX, sY

The 'LOAD' instructions provides a simple way to define the contents of any register (sX). The value loaded into a register can a fixed value (kk) or the value contained in any register (sY) can be copied. The states of the zero flag (Z) and the carry flag (C) will be unaffected.

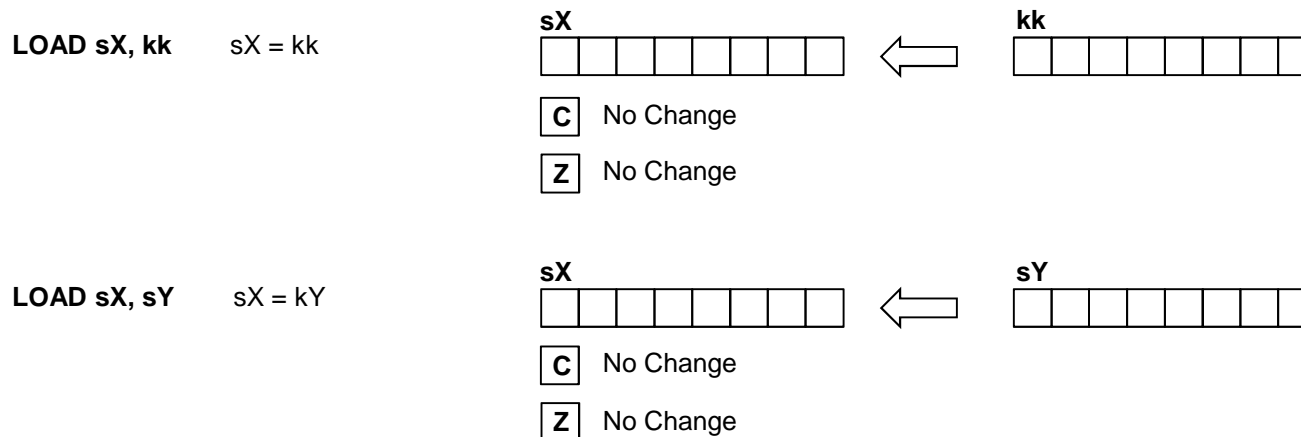

Examples

```
LOAD sA, 8E
LOAD s4, 42'd
LOAD s9, 10001110'b
LOAD s6, "k"
LOAD s7, sA
LOAD s5, CR
```

The KCPSM6 assembler enables constant values in all instructions that require them to be defined in hexadecimal (default), decimal, binary or using a single character which is converted to its ASCII equivalent value.

After this example has executed...

's7', 's9' and 'sA' will all contain 8E hex.

'sA' will contain 2A hex

's6' will contain 77 hex (the ASCII code for 'k') and 's5' will contain 0D hex (the ASCII code for Carriage Return) .

Hint - Loading a register with itself has no effect other than taking 2 clock cycles but this can be useful way to create a known delay.

Notes

'sX' and 'sY' define any of the 16 registers in the range 's0' through to 'sF' in the active register bank. Please see the 'Using Register Banks' section to see how to switch between the 'A' and 'B' register banks and techniques for copying values from registers in one bank to registers in the other.

The instruction op-code 00000 hex was specifically assigned to be the instruction 'LOAD s0, s0'. In this way the default value (zero) of any unused program memory contents will have the minimum effect should an improper program result in these undefined locations being executed.

AND sX, kk

AND sX, sY

The 'AND' instructions perform the bit-wise logical AND operation.

The first operand must specify a register 'sX' whose value provides one input to the AND operation and in to which the result is returned.
 The second operand defines the second input to the AND operation and can either be an 8-bit constant 'kk' or a register 'sY'.
 The zero flag (Z) will be set if all 8-bits of the result returned to 'sX' are zero.
 The carry flag (C) will be cleared (C=0) in all cases.

AND sX, kk $sX = sX \text{ AND } kk$
AND sX, sY $sX = sX \text{ AND } sY$

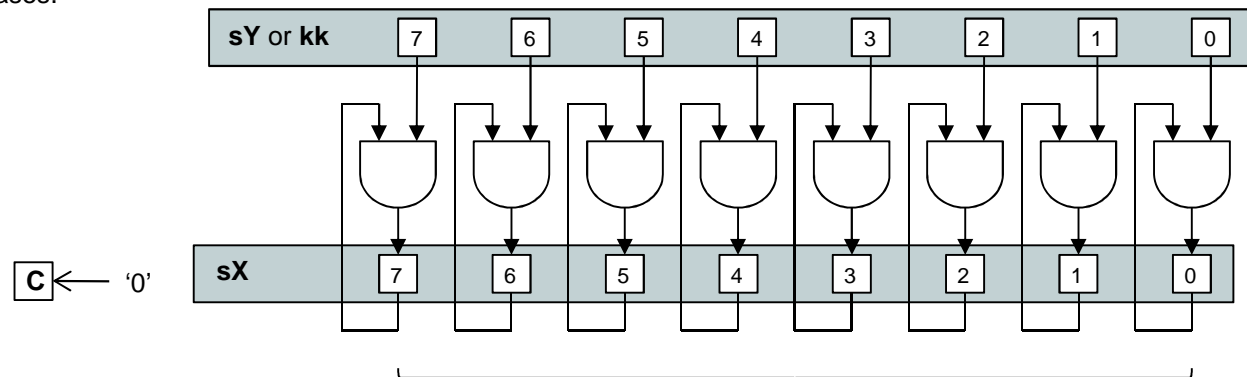

Examples

```
LOAD sA, CA
AND sA, 53
```

sA = 42, Z=0, C=0.

```
CA = 1 1 0 0 1 0 1 0
53 = 0 1 0 1 0 0 1 1
CA AND 53 = 0 1 0 0 0 0 1 0 = 42
```

Z ← = '00' ?

Reference

A	B	A AND B
0	0	0
0	1	0
1	0	0
1	1	1

```
LOAD sA, CA
LOAD sB, 14
AND sA, sB
```

sA = 00, Z=1, C=0.

```
CA = 1 1 0 0 1 0 1 0
14 = 0 0 0 1 0 1 0 0
CA AND 14 = 0 0 0 0 0 0 0 0 = 00
```

```
AND s5, 00001111'b
```

Hint – This will clear the upper nibble of 's5' and could be used to convert the ASCII characters '0' to '9' (30 to 39 hex) into their equivalent numerical values (00 to 09 hex).

```
CONSTANT bit2, 00000100'b
AND s0, ~bit2
```

Hint – 'AND' provides a way to clear bits to '0'. In this example bit2 of register s0 is cleared. Note how all bits of a CONSTANT can be locally inverted using ~ before the name. Hence the constant actually applied in this case is 11111011'b. (see 'OR' for setting bits).

```
AND s5, FF
```

Coding Tip – Clears the Carry Flag with no change to register contents (see also HWBUILD).

OR sX, kk

OR sX, sY

The 'OR' instructions perform the bit-wise logical OR operation.

The first operand must specify a register 'sX' whose value provides one input to the OR operation and in to which the result is returned. The second operand defines the second input to the OR operation and can either be an 8-bit constant 'kk' or a register 'sY'. The zero flag (Z) will be set if all 8-bits of the result returned to 'sX' are zero. The carry flag (C) will be cleared (C=0) in all cases.

OR sX, kk sX = sX OR kk

OR sX, sY sX = sX OR sY

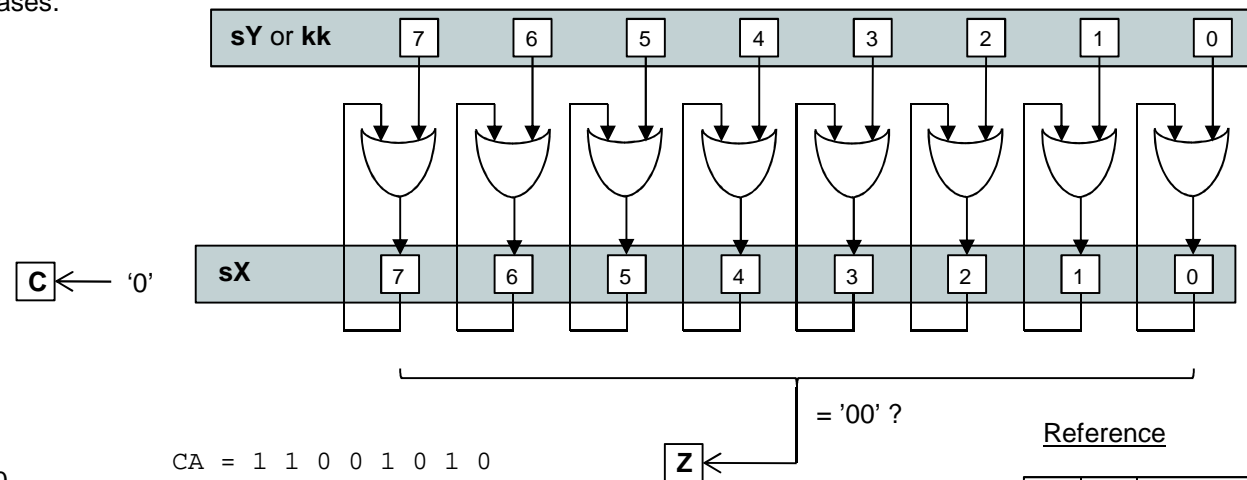

Examples

LOAD sA, CA
OR sA, 53

sA = DB, Z=0, C=0.

CA = 1 1 0 0 1 0 1 0
53 = 0 1 0 1 0 0 1 1
CA OR 53 = 1 1 0 1 1 0 1 1 = DB

LOAD sA, CA
LOAD sB, 14
OR sA, sB

sA = DE, Z=0, C=0.

CA = 1 1 0 0 1 0 1 0
14 = 0 0 0 1 0 1 0 0
CA OR 14 = 1 1 0 1 1 1 1 0 = DE

Reference

A	B	A OR B
0	0	0
0	1	1
1	0	1
1	1	1

OR s5, 00110000'b

Hint – This sets 2 bits in the upper nibble of 's5' and could be used to convert the numerical values 00 to 09 hex into their ASCII equivalent characters '0' to '9' (30 to 39 hex).

CONSTANT bit2, 00000100'b
OR s0, bit2

Hint – 'OR' provides a way to set bits to '1'. The CONSTANT directive provides a convenient way to name bits that you may wish to control in this way (see 'AND' for clearing bits).

XOR sX, kk

XOR sX, sY

The 'XOR' instructions perform the bit-wise logical exclusive-OR operation.

The first operand must specify a register 'sX' whose value provides one input to the XOR operation and in to which the result is returned.

The second operand defines the second input to the XOR operation and can either be an 8-bit constant 'kk' or a register 'sY'.

The zero flag (Z) will be set if all 8-bits of the result returned to 'sX' are zero.

The carry flag (C) will be cleared (C=0) in all cases.

XOR sX, kk $sX = sX \text{ XOR } kk$

XOR sX, sY $sX = sX \text{ XOR } sY$

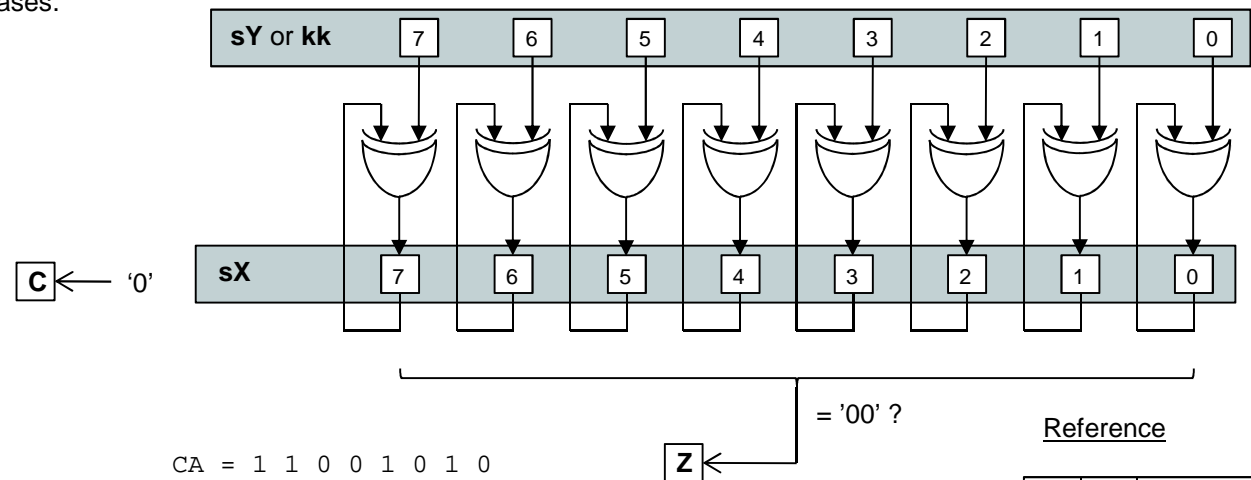

Examples

```
LOAD sA, CA
XOR sA, 53
```

sA = 99, Z=0, C=0.

```
CA = 1 1 0 0 1 0 1 0
53 = 0 1 0 1 0 0 1 1
CA XOR 53 = 1 0 0 1 1 0 0 1 = 99
```

```
LOAD sA, CA
LOAD sB, 14
XOR sA, sB
```

sA = DE, Z=0, C=0.

```
CA = 1 1 0 0 1 0 1 0
14 = 0 0 0 1 0 1 0 0
CA XOR 14 = 1 1 0 1 1 1 1 0 = DE
```

Reference

A	B	A XOR B
0	0	0
0	1	1
1	0	1
1	1	0

```
CONSTANT strobe, 00000001'b
XOR s0, strobe
OUTPUT s0, ctrl_port
XOR s0, strobe
OUTPUT s0, 0 ctrl_port
```

Hint – The XOR instruction can be used to toggle the state of bits within a register. In this example the least significant bit of 's0' is twice toggled and output to a port. Assuming the LSB was '0' to begin with then this will have generated a positive ('1') pulse on the LSB of the output port whilst all other bits remained unaffected. The CONSTANT directive provides a convenient way to name bits that you may wish to control in this way.

ADD sX, kk

ADD sX, sY

The 'ADD' instructions perform the arithmetic addition of two 8-bit values and set the carry and zero flags according to the result.

The first operand must specify a register 'sX' whose value provides one input to the addition function and in to which the result is returned.

The second operand defines the second input to the addition and can either be an 8-bit constant 'kk' or a register 'sY'.

The zero flag (Z) will be set if the 8-bit result returned to 'sX' is zero.

The carry flag (C) will be set if the addition results in an overflow.

ADD sX, kk $sX = sX + kk$

ADD sX, sY $sX = sX + sY$

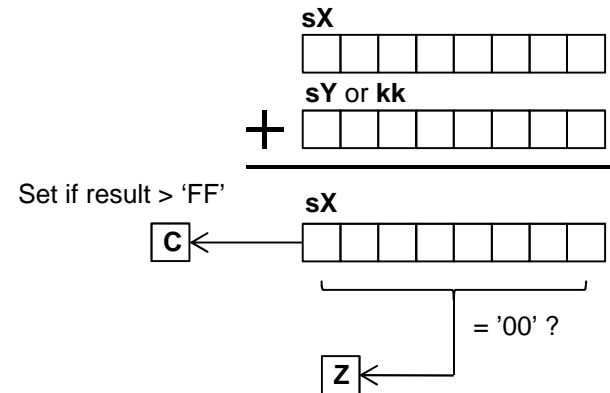

Examples

LOAD sA, 8E
ADD sA, 43 $8E + 43 = D1$ $sA = D1$ which is not zero ($Z=0$) and with no overflow ($C=0$).

LOAD sA, 142'd
ADD sA, sA $142 + 142 = 284$ $284 = 256 + 28$ hence $sA = 28$ (1C hex) which is not zero ($Z=0$) and there has been an overflow ($C=1$).

LOAD sA, 8E
ADD sA, 72 $8E + 72 = 100$ $sA = 00$ which is zero ($Z=1$) but there was also an overflow that made this happen ($C=1$).

ADDCY sX, kk

ADDCY sX, sY

The 'ADDCY' instructions are primarily intended as an extension to the basic 'ADD' instructions in order to support arithmetic addition of values more than 8-bits. The key difference from the ADD instructions is that the zero and carry flags are also used as inputs to the addition function and these can influence both the 8-bit result and the new states of the flags. Although each register only contains an 8-bit value, any combination of registers can be used to hold larger values segmented into bytes. For example a 32-bit value can be held in a 4 registers. Although there is no restriction on which registers, and no formal way of describing the assignment, it is common practice to assign adjacent registers and refer to them as a 'register set' such as [sD, sC, sB, sA].

The first operand must specify a register 'sX' whose value provides one input to the addition function and in to which the result is returned. The second operand defines the second input to the addition and can either be an 8-bit constant 'kk' or a register 'sY'. The zero flag (Z) will be set if the 8-bit result returned to 'sX' is zero and the zero flag was set prior to the ADDCY instruction. The carry flag (C) will be set if the addition results in an overflow.

ADDCY sX, kk $sX = sX + kk + C$

ADDCY sX, sY $sX = sX + sY + C$

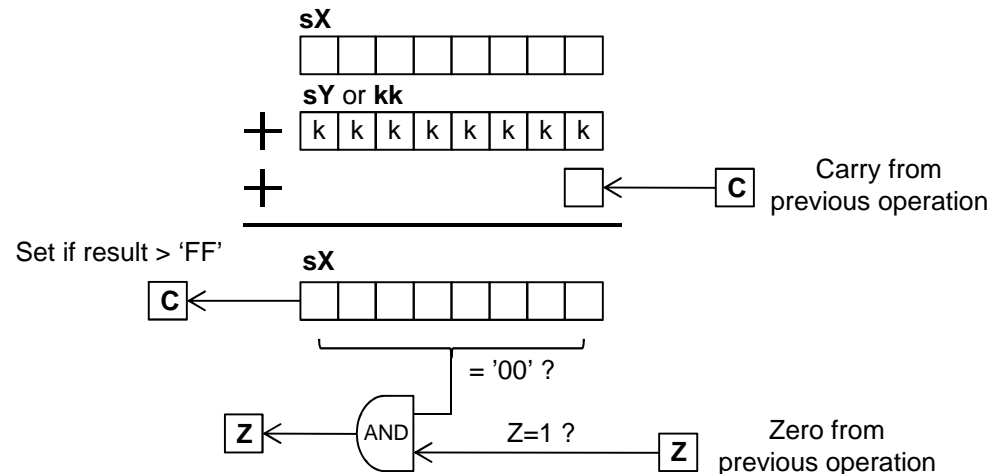

Examples

The key observation to make as illustrated by these examples is that carry and zero flags reflect the entire result of a multi-byte addition. In particular, the zero flag is only set if the complete multi-byte result is zero and is not just based on the 8-bit result of the final ADDCY operation.

<pre>LOAD sA, 7B LOAD sB, A2 ADD sA, 85 ADDCY sB, 5D</pre>	<p>[sB, sA] = A2 7B + 5E 1A = 10095</p> <p>7B + 1A = 95 sA = 95, Z=0, C=0. A2 + 5E + 0 = 100 sB = 00, Z=0, C=1.</p>
--	---

<pre>LOAD sA, 7B LOAD sB, A2 ADD sA, 85 ADDCY sB, 5D</pre>	<p>[sB, sA] = A2 7B + 5D 85 = 10000</p> <p>7B + 85 = 100 sA = 00, Z=1, C=1. A2 + 5D + 1 = 100 sB = 00, Z=1, C=1.</p>
--	--

SUB sX, kk

SUB sX, sY

The 'SUB' instructions perform the arithmetic subtraction of two 8-bit values and set the carry and zero flags according to the result.

The first operand must specify a register 'sX' from which the second operand will be subtracted and to which the result is returned.

The second operand defines the value to be subtracted from the first operand and can either be an 8-bit constant 'kk' or a register 'sY'.

The zero flag (Z) will be set if the 8-bit result returned to 'sX' is zero.

The carry flag (C) will be set if the result of the subtraction is negative. Hence the carry flag represents an underflow or a 'borrow' to complete the operation.

SUB sX, kk $sX = sX - kk$

SUB sX, sY $sX = sX - sY$

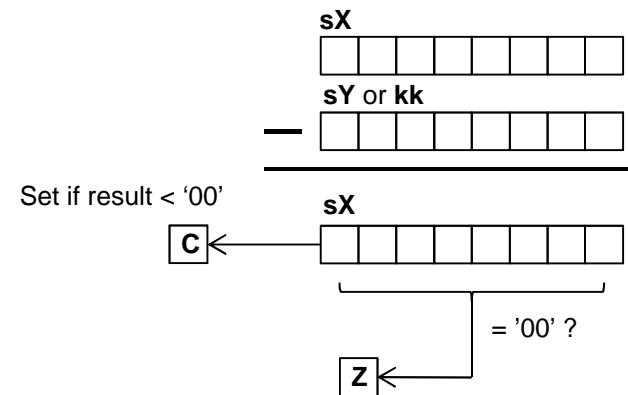

Examples

```
LOAD sA, 8E
SUB sA, 43
```

$8E - 43 = 4B$ $sA = 4B$ which is not zero ($Z=0$) and with no underflow ($C=0$).

```
LOAD sA, 8E
ADD sA, sA
```

$8E - 8E = 00$ $sA = 00$ which is zero ($Z=1$) but there was still no underflow ($C=0$).

```
LOAD sA, 8E
SUB sA, B5
```

$8E - B5 = 1D9$ $sA = D9$ which is not zero ($Z=0$) but there was an underflow ($C=1$).
This is equivalent to $142 - 181 = -39$ where $D9$ hex is the two's complement representation of -39 .
However, it is the user's responsibility to implement and interpret signed arithmetic values and operations.

SUBCY sX, kk

SUBCY sX, sY

The 'SUBCY' instructions are primarily intended as an extension to the basic 'SUB' instructions in order to support arithmetic subtraction of values more than 8-bits. The key difference from the SUB instructions is that the zero and carry flags are also used as inputs to the subtraction function and these can influence both the 8-bit result and the new states of the flags. Although each register only contains an 8-bit value, any combination of registers can be used to hold larger values segmented into bytes. For example a 32-bit value can be held in a 4 registers. Although there is no restriction on which registers, and no formal way of describing the assignment, it is common practice to assign adjacent registers and refer to them as a 'register set' such as [sD, sC, sB, sA].

The first operand must specify a register 'sX' from which the second operand and carry flag will be subtracted and to which the result is returned. The second operand defines the value to be subtracted from the first operand and can either be an 8-bit constant 'kk' or a register 'sY'. The zero flag (Z) will be set if the 8-bit result returned to 'sX' is zero and the zero flag was set prior to the SUBCY instruction. The carry flag (C) will be set if the result of the subtraction is negative. Hence the carry flag represents an underflow or a 'borrow' to complete the operation.

SUBCY sX, kk $sX = sX - kk - C$

SUBCY sX, sY $sX = sX - sY - C$

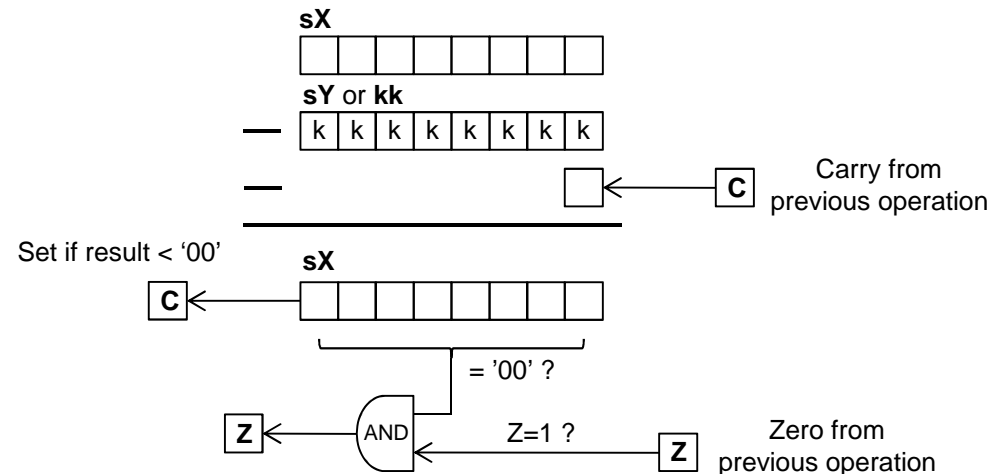

Examples

The key observation to make as illustrated by these examples is that carry and zero flags reflect the entire result of a multi-byte subtraction. In particular, the zero flag is only set if the complete multi-byte result is zero and is not just based on the 8-bit result of the final SUBCY operation.

<pre>LOAD sA, 7B LOAD sB, A2 SUB sA, B9 SUBCY sB, A1</pre>	<p>[sB, sA] = A2 7B - A1 B9 = 00C2</p> <p>7B - B9 = (-)C2 sA = C2, Z=0, C=1. A2 - A1 - 1 = 00 sB = 00, Z=0, C=0.</p>
--	--

<pre>LOAD sA, 7B LOAD sB, A2 SUB sA, sA SUBCY sB, sB</pre>	<p>[sB, sA] = A2 7B - A2 7B = 0000</p> <p>7B - 7B = 00 sA = 00, Z=1, C=0. A2 - A2 - 0 = 00 sB = 00, Z=1, C=0.</p>
--	---

TEST sX, kk

TEST sX, sY

The 'TEST' instructions are similar to the 'AND' instructions in that a bit-wise logical AND operation is performed. However, the actual result is discarded and only the flags are updated to reflect the temporary 8-bit. The 'TEST' instruction also reports then exclusive-OR of the temporary result which can be used to compute the 'odd parity' of a value.

The first operand must specify a register 'sX' whose value provides one input to the AND operation (sX will not be effected by the operation). The second operand defines the second input to the AND operation and can either be an 8-bit constant 'kk' or a register 'sY'. The zero flag (Z) will be set if all 8-bits of the temporary result are zero. The carry flag (C) will be set if the temporary result contains an odd number of bits set to '1' (the exclusive-OR of the 8-bit temporary result).

TEST sX, kk temp = sX AND kk

TEST sX, sY temp = sX AND sY

Hints

It is typical to think of 'sX' containing the information to be tested and for 'sY' or 'kk' to be acting as a bit-mask to select only those bits to be tested.

To test a single bit the value of 'kk' is best described using a binary format such as 00100000'b that will test bit 5 (equivalent to 20 hex). The 'C' flag will be set if the corresponding bit in 'sX' is '1' and the 'Z' flag will be set if the tested bit is '0'.

Use a mask value of kk = FF to compute the odd parity of the whole byte contained in 'sX'.

Examples

```
LOAD sA, CA
TEST sA, 01000000'b
```

Z=0, C=1 (odd).

```
CA = 1 1 0 0 1 0 1 0
40 = 0 1 0 0 0 0 0 0
CA AND 40 = 0 1 0 0 0 0 0 0 = 40
```

```
LOAD sA, 51
TEST sA, FF
```

Z=0, C=1.
Parity is odd.

```
51 = 0 1 0 1 0 0 0 1
FF = 1 1 1 1 1 1 1 1
51 AND FF = 0 1 0 1 0 0 0 1 = 51
```

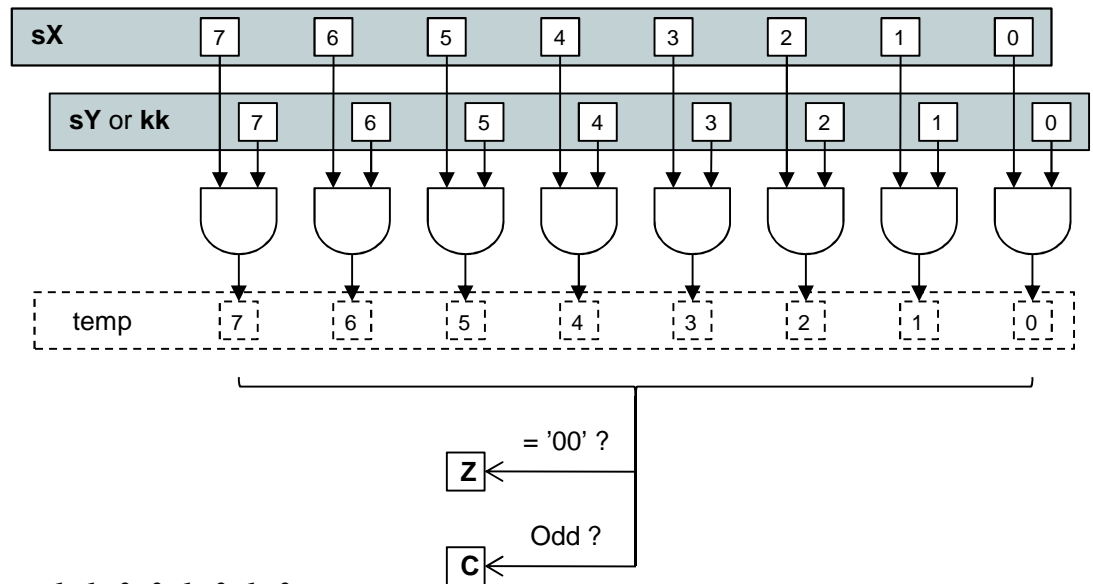

Hint – The 'SLA' and 'SRA' shift instructions and the ADDCY and SUBCY instructions can all be used to move the value of the carry flag into a register.

TESTCY sX, kk

TESTCY sX, sY

The 'TESTCY' instructions are primarily intended as an extension to the basic 'TEST' instructions in order to support testing and odd parity calculation of values more than 8-bits. The key difference from the TEST instructions is that the zero and carry flags are also used as inputs that can influence the new states of the flags. Although each register only contains an 8-bit value, any combination of registers can be used to hold larger values segmented into bytes. For example a 32-bit value can be held in a 4 registers. Although there is no restriction on which registers, and no formal way of describing the assignment, it is common practice to assign adjacent registers and refer to them as a 'register set' such as [sD, sC, sB, sA].

The first operand must specify a register 'sX' whose value provides one input to the AND operation (sX will not be effected by the operation). The second operand defines the second input to the AND operation and can either be an 8-bit constant 'kk' or a register 'sY'. The zero flag (Z) will be set if all 8-bits of the temporary result are zero and the zero flag was set prior to the TESTCY instruction. The carry flag (C) will be set if the temporary result together with the previous state of the carry flag contains an odd number of bits set to '1'.

TEST sX, kk temp = sX AND kk
TEST sX, sY temp = sX AND sY

The meaning of the 'C' and 'Z' flags are the same following a TEST and TESTCY combination of instructions used to test and compute the odd parity of a multi-byte value as they are after a single 8-bit TEST operation.

Examples

```
LOAD sA, CA
LOAD sB, 52
TEST sA, FF
TESTCY sB, FF
```

[sB, sA] = 11001010 0101001
 7 bits in total are '1' so parity is odd. Z=0, C=1.

```
LOAD sA, CA
LOAD sB, 52
TEST sA, 00000100'b
TESTCY sB, 00100000'b
```

[sB, sA] = 11001010 0101001
 Both bit13 and bit3 of the 16-bit word are '0'.
 Z=1, C=0 (even).

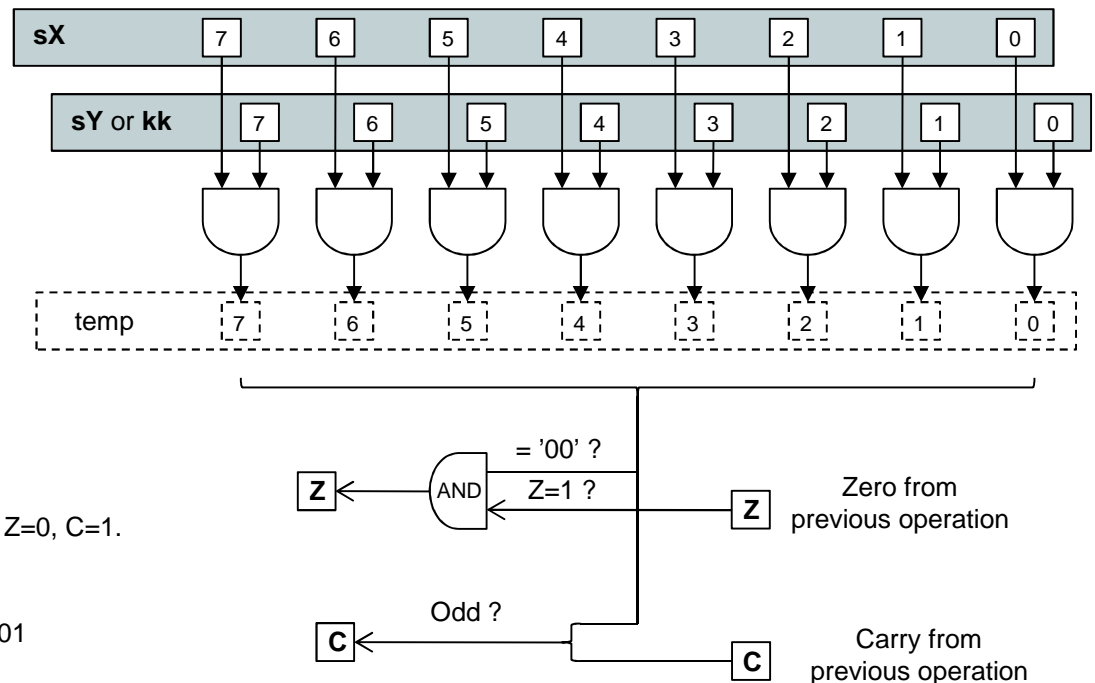

COMPARE sX, kk

COMPARE sX, sY

The 'COMPARE' instructions perform the arithmetic subtraction of two 8-bit values but the actual result is discarded and only the carry and zero flags are updated according to the temporary result.

The first operand must specify a register 'sX' from which the second operand will be subtracted (the value of sX will not be effected by the operation). The second operand defines the value to be subtracted from the first operand and can either be an 8-bit constant 'kk' or a register 'sY'. The zero flag (Z) will be set if the temporary 8-bit result is zero corresponding with both operand being equal or 'matching'. The carry flag (C) will be set if the temporary result of the subtraction is negative and hence indicating when 'sX' is less than the second operand.

Flag States		Comparison
Z	C	
0	0	sX > kk or sX > sY
x	1	sX < kk or sX < sY
1	x	sX = kk or sX = sY

COMPARE sX, kk temp = sX - kk

COMPARE sX, sY temp = sX - sY

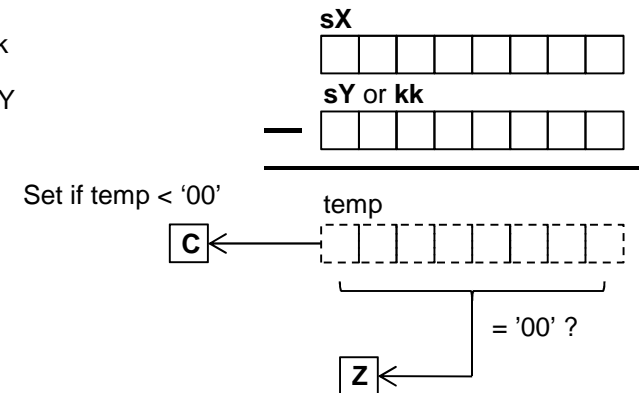

Examples

```
LOAD sA, 8E
COMPARE sA, 8E
JUMP Z, equal
```

Values are equal, Z=1, C=0.

```
LOAD sA, 8E
COMPARE sA, 98
JUMP C, less_than
```

sA < 98, Z=0, C=1.

Hints

Use 'Z' to determine when the values are equal or 'match'.

The 'C' flag can be used to determine when sX is less than the second operand. Hence, it can also be used to determine when sX is greater than or equal to the second operand'. So when comparing the contents of two registers assign them to 'sX' and 'sY' such that you can use 'C' to identify which is less. This will avoid the requirement to test both 'C' and 'Z' flags.

The KSPSM6 Assembler enables you to specify constants in hex, decimal and ASCII characters, e.g. COMPARE s0, "Q"

COMPARECY sX, kk

COMPARECY sX, sY

The 'COMPARECY' instructions are primarily intended as an extension to the basic 'COMPARE' instructions in order to support comparison of values more than 8-bits. The key difference from the COMPARE instructions is that the zero and carry flags are also used as inputs to the subtraction used to perform the comparison and these can influence both the 8-bit result before it is discarded and the new states of the flags. Although each register only contains an 8-bit value, any combination of registers can be used to hold larger values segmented into bytes. For example a 32-bit value can be held in a 4 registers. Although there is no restriction on which registers, and no formal way of describing the assignment, it is common practice to assign adjacent registers and refer to them as a 'register set' such as [sD, sC, sB, sA].

The first operand must specify a register 'sX' from which the second operand and carry flag will be subtracted (sX will not be effected by the operation). The second operand defines the value to be subtracted from the first operand and can either be an 8-bit constant 'kk' or a register 'sY'. The zero flag (Z) will be set if the temporary 8-bit result is zero and the zero flag was set prior to the COMPARECY instruction. The carry flag (C) will be set if the temporary result of the subtraction is negative.

COMPARECY sX, kk temp = sX - kk - C

COMPARECY sX, sY temp = sX - sY - C

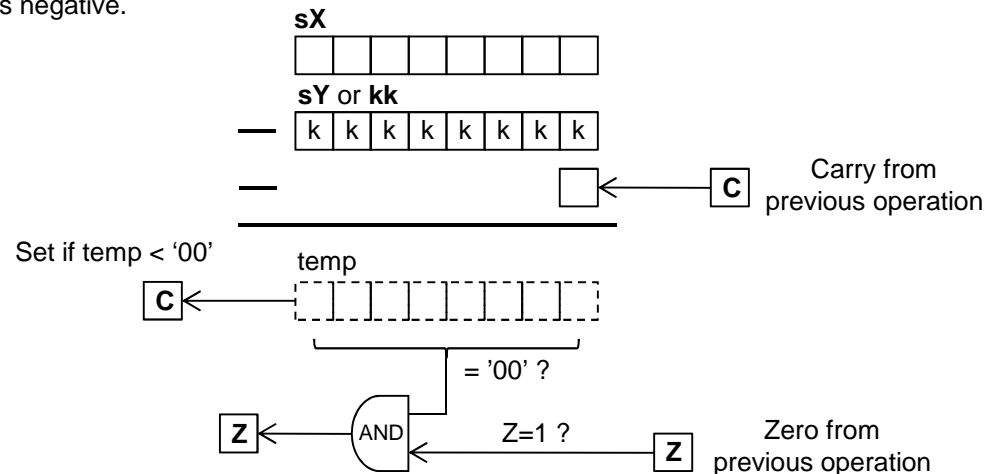

Examples

The meaning of the 'C' and 'Z' flags are the same following a COMPARE and COMPARECY combination of instructions used to compare multi-byte values as they are after a single 8-bit COMPARE operation.

```
LOAD sA, 7B
LOAD sB, A2
LOAD sC, 14
COMPARE sA, 7B
COMPARECY sB, A2
COMPARECY sC, 14
JUMP Z, equal
```

[sC,sB, sA] = 14 A2 7B

14A27B - 14A27B = 000000

Values are equal Z=1, C=0.

```
LOAD sA, 7B
LOAD sB, A2
COMPARE sA, 7B
COMPARECY sB, B9
JUMP C, less_than
```

[sB, sA] = A2 7B

A27B - B97B = (-) E900

[sB, sA] < B97B Z=0, C=1.

SL0 sX

SL1 sX

SLX sX

SLA sX

These instructions all shift the contents of the specified register (sX) one bit to the left. The most significant bit (MSB) is shifted out of the register into the carry flag (C). The bit that is shifted into the least significant bit (LSB) is defined by the shift left instruction that is used. The zero flag (Z) will be set only if all 8-bits of the resulting value contained in the register are zero.

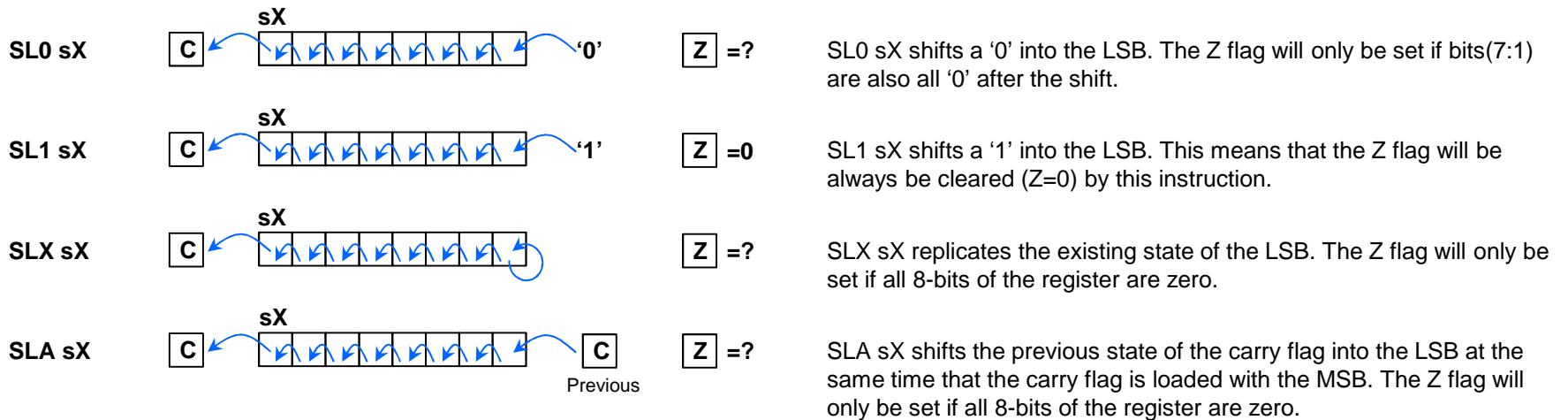

Examples

A shift left injecting a '0' has the effect of multiplying a value by 2. The 'SLA' instruction enables multi-byte values contained in multiple registers to be shifted.

```
LOAD sB, 14
LOAD sA, B5 [sB,sA] = 14B5 = 530110 = 0001 0100 1011 0101
SL0 sA
SLA sB [sB,sA] = 296A = 1060210 = 0010 1001 0110 1010
```

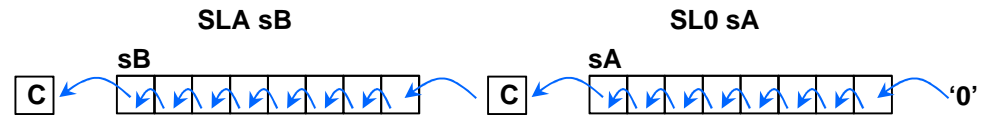

```
LOAD sF, 00000001'b
loop: OUTPUT sF, port
SLX sF
JUMP NC, loop
```

Outputs a simple pattern shown on the right hand side to the 'port'. The process terminates when all 8-bits have been set and the final shift sets the carry flag.



SR0 sX

SR1 sX

SRX sX

SRA sX

These instructions all shift the contents of the specified register (sX) one bit to the right. The least significant bit (LSB) is shifted out of the register into the carry flag (C). The bit that is shifted into the most significant bit (MSB) is defined by the shift right instruction that is used. The zero flag (Z) will be set only if all 8-bits of the resulting value contained in the register are zero.

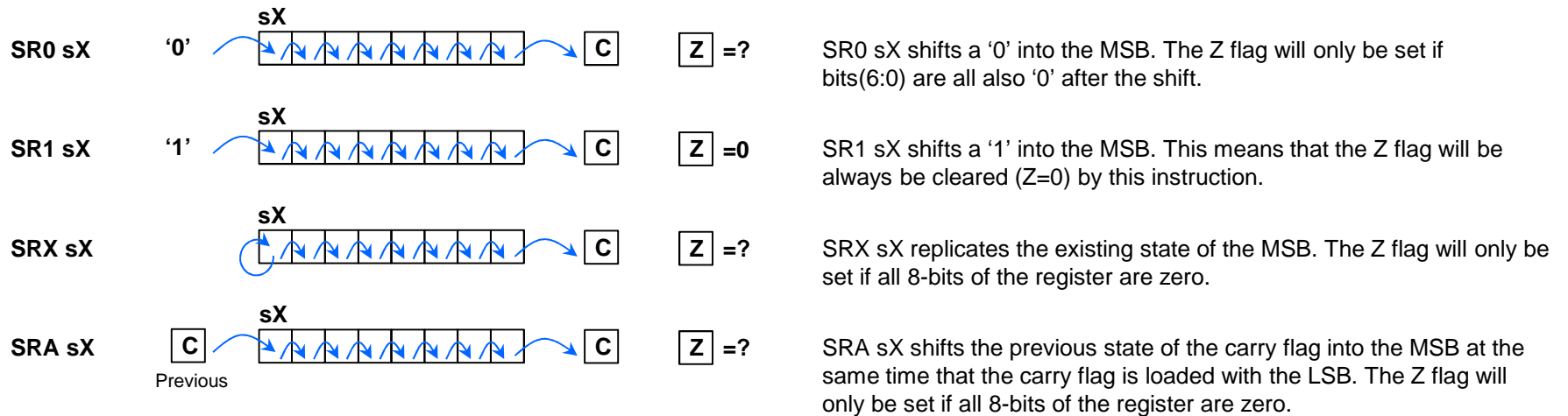

Examples

A shift right has the effect of dividing a value by 2. The 'SRA' instruction enables multi-byte values contained in multiple registers to be shifted. When 2's complement is used to represent signed values then 'SRX' implements sign extension.

```
LOAD sB, ED
LOAD sA, 2A [sB,sA] = ED2A = -482210 = 1110 1101 0010 1010
SL0 sA
SLA sB [sB,sA] = F695 = -241110 = 1111 0110 1001 0101
```

```
LOAD sF, 10000000'b
loop: OUTPUT sF, port
SR0 sF
JUMP NC, loop
```

Outputs to 'port' a simple 'walking 1' pattern as illustrated on the right hand side. The process terminates when the '1' is shifted into the carry flag.

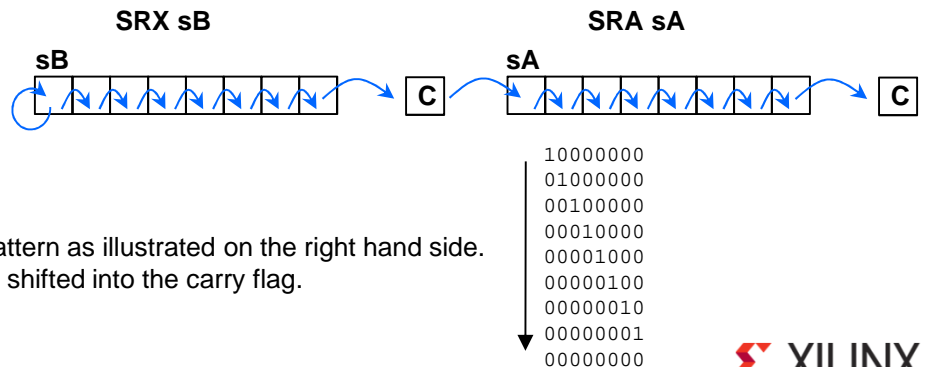

RL sX

RR sX

The 'RL' and 'RR' instructions rotate the contents of the specified register (sX) one bit to the left or right. The bit that is shifted out of one end of the register and back into the other end is also copied into the carry flag (C). The zero flag (Z) will be set only if all 8-bits of the register contents are zero.

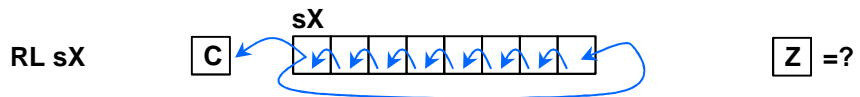

RL sX shifts all bits one place to the left and the MSB that is shifted out is shifted into the LSB as well as copied into the carry flag. The Z flag will only be set if all bits of the register are zero.

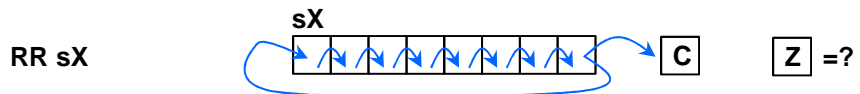

RR sX shifts all bits one place to the right and the LSB that is shifted out is shifted into the MSB as well as copied into the carry flag. The Z flag will only be set if all bits of the register are zero.

Note that because the rotate instructions only reorganize the existing contents of 'sX' the zero flag will only be set if 'sX' contained zero on entry to the rotate operation.

Example

Rotate operations are typically used in the generations of bit patterns or sequences such as in the control of stepper motors.

```
LOAD s6, 03
loop: OUTPUT s6, motor_ctrl
CALL step_delay
INPUT s0, direction
TEST s0, 01
JUMP NZ, move_right
RL s6
JUMP loop
move_right: RR s6
JUMP loop
```

In this example we can imagine a stepper motor that has 8 coils arranged in a circle such that the coil mapped to bit0 is adjacent to the coil mapped to bit7. The position of the motor is defined by the coils being energised and in this case it is beneficial to energise two adjacent coils of a motor at the same time (hence the initial value of 03 loaded into 's6').

An input is sampled to determine in which direction the motor should rotate and this is translated into the direction in which the "11" pattern is rotated either to the left or right.

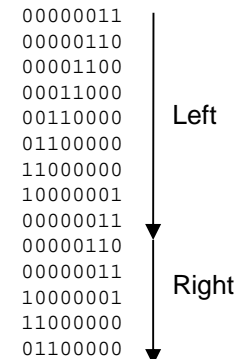

REGBANK A

REGBANK B

KCPSM6 actually has 32 registers that are arranged into 2 banks of 16 registers called bank 'A' and bank 'B'. Only one bank can be active at a given time and all instructions (except 'STAR') can only perform operations involving the registers in the active bank. To put it another way the registers in the inactive bank are almost completely isolated and their contents are unaffected by instructions modifying values within the registers of the active bank.

Following device configuration or an active High reset pulse on the 'reset' input of the KCPSM6 macro bank 'A' will be the active bank. Hence KCPSM6 can initially be considered to have 16 registers and this will be adequate for many applications.

The REGBANK instruction can be used to select which bank is to be active and therefore assign the other bank to being inactive. There is only one carry flag and one zero flag neither of which is effected by the bank selection.

REGBANK A - Select bank A active (or restore default bank).

REGBANK B - Select bank B active.

Hint – When selecting a different bank there is no effect on the contents of any registers in either bank. However, it will almost certainly appear as if the contents of all registers change as the swap is made. Note that there is only one set of flags and their values will not change.

Hint - If you use the NAMEREG directive in your code then you will probably want to assign different names to the registers following the REGBANK instruction to reflect that you are no longer accessing the same information.

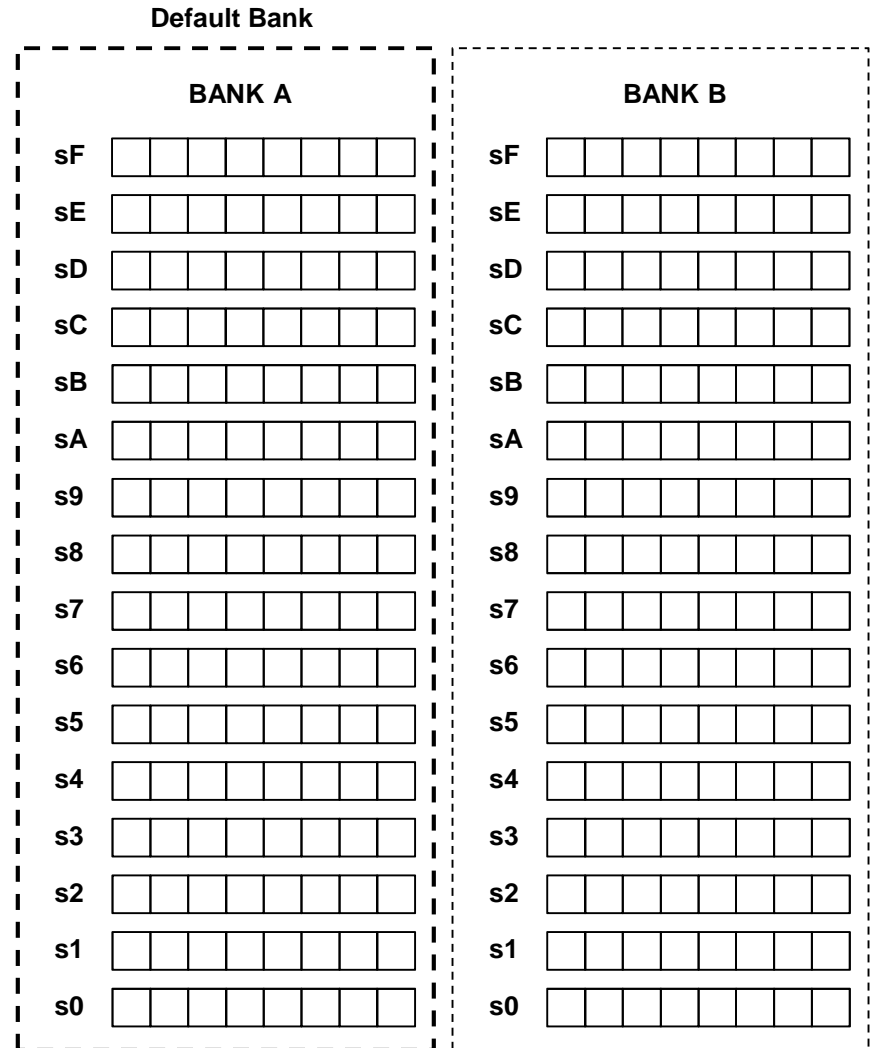

STAR sX, sY

Apart from bank 'A' being the default on power up or following a reset you are completely free to select bank 'A' or bank 'B' as an when you wish using the REGBANK instruction. All instructions only operate on the registers in the actively selected bank which preserves the values in the inactive bank. This can be particularly useful when creating a subroutine that implements an intense task where having many registers available to manipulate data can make the task much easier to implement. It is also very appealing when servicing an interrupt as it can really help to ensure that the contents of registers being used anywhere else in the program at the time of the interrupt are not disturbed. This is covered in more detail in the interrupt section of this guide (see page 86).

KCPSM3 only had one bank of registers, so a common technique was to preserve the contents of registers in scratch pad memory before those registers were used again in a subroutine. The values were then fetched from memory to restore those values before returning to the main program. This is still a perfectly valid technique in KCPSM6 programs but it can result in a significant number of STORE and FETCH instructions consuming code space and slowing program execution. By switching to the 'B' bank of registers at the start of an intense subroutine, or when servicing and interrupt, you could effectively provide yourself with 16 temporary registers in one instruction cycle (2 system clock cycles) automatically preserving the contents of registers in bank 'A'.

Although it is useful to have two banks of registers that are isolated and independent this also presents a challenge when it comes to data being passed between a main program and a subroutine. Once again a potential solution is to assign particular scratch pad memory locations which are then accessed by both sections of code using different register banks but this requires a memory location and a pair of STORE and FETCH instructions for each byte of data. For this reason the 'Send To Alternate Reregister' ('STAR') instruction provides you with a way to pass information from a register in the active bank (sY) to a register in the inactive bank (sX).

STAR sX, sY

Hint – 'STAR sX, sY' is almost exactly the same as a 'LOAD sX, sY' and also has no effect on the states of the flags. However it should be recognised that 'STAR s0, s0' is definitely *not* equivalent to a 'no-operation' instruction because each reference to 's0' is in a different bank and therefore the contents of 's0' in the inactive bank will probably be changed.

Example `STAR sE, s1` 'sE' in the inactive bank is loaded with a copy of 's1' in the active bank (illustrated in the diagram above).

ASSEMBLER CODING REQUIREMENT

The alternate register 'sX' *must be* specified using a default name 's0' to 'sF'. Any NAMEREG directives do not apply to the specification of 'sX'. The current active register 'sY' *must be* specified using an active name for a register (i.e. NAMEREG does apply as normal). These are deliberate coding rules intended to minimise the probability of coding mistakes (i.e. They force you to think carefully about what bank is active).

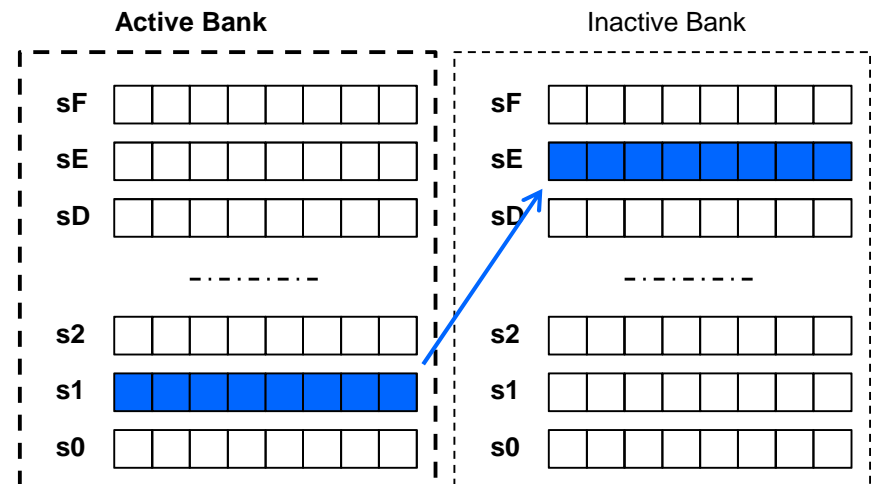

No Change

No Change

General Purpose I/O Ports

This design has been used to evaluate the maximum clock rates that can be achieved for a variety of device types and speed grades...

Spartan-6: (-1L) ~82MHz	(-2) ~105MHz	(-3) ~136MHz
Virtex-6:		(-3) ~238MHz
Kintex-7: (-1) ~185MHz		(-3) ~238MHz
Virtex-7:		(-3) ~232MHz

Input Ports

- A = PORT 00
- B = PORT 01
- C = PORT 02
- D = PORT 03

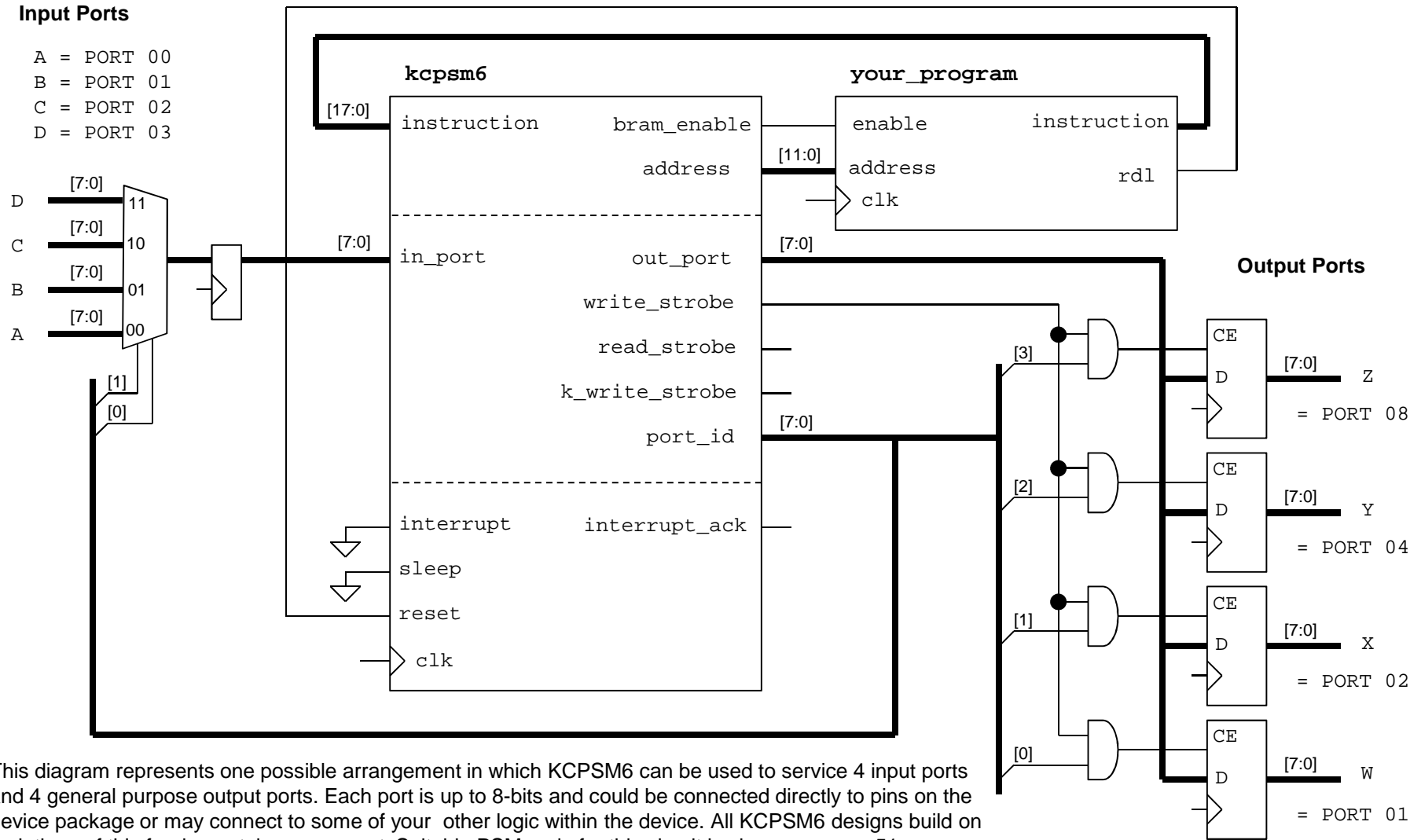

This diagram represents one possible arrangement in which KCPSM6 can be used to service 4 input ports and 4 general purpose output ports. Each port is up to 8-bits and could be connected directly to pins on the device package or may connect to some of your other logic within the device. All KCPSM6 designs build on variations of this fundamental arrangement. Suitable PSM code for this circuit is shown on page 51.

INPUT sX, pp

INPUT sX, (sY)

An 'INPUT' instruction enables KCPSM6 to read information from the from your hardware design into a register 'sX' using a general purpose input port specified by an 8-bit constant value 'pp' or the contents of another register '(sY)'. KCPSM6 presents the port address defined by 'pp' or '(sY)' on 'port_id' and your hardware interface is then responsible for selecting and presenting the appropriate information to the 'in_port' so that it can be captured into the 'sX' register. An active High ('1') synchronous pulse is also generated on the 'read_strobe' pin and may be used by the hardware interface to confirm when a particular port has been read.

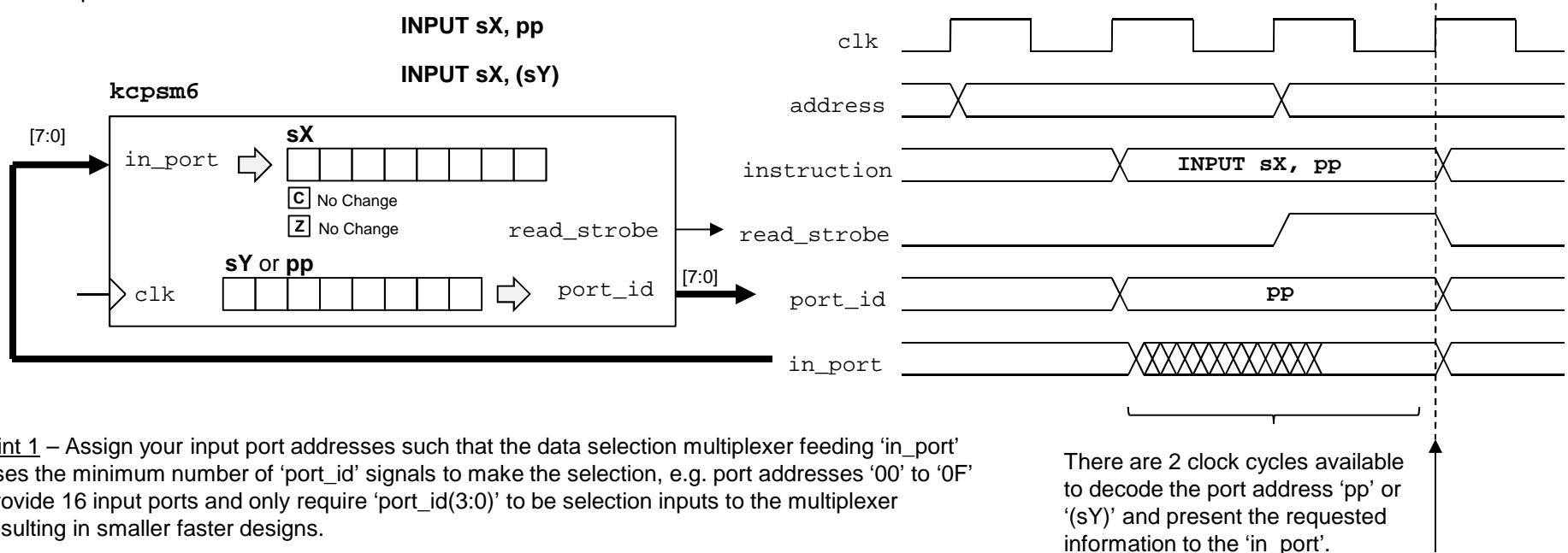

Hint 1 – Assign your input port addresses such that the data selection multiplexer feeding 'in_port' uses the minimum number of 'port_id' signals to make the selection, e.g. port addresses '00' to '0F' provide 16 input ports and only require 'port_id(3:0)' to be selection inputs to the multiplexer resulting in smaller faster designs.

Hint 2 – Unless there is a specific reason not to, the input data selection multiplexer should include a pipeline register (i.e. your case statement should be within a clocked process). In this way the data is selected during the first clock cycle of 'port_id' and presented to 'in_port' during the second clock cycle. Failure to define a pipeline register anywhere in the 'port_id' to 'in_port' path is the most common reason for PicoBlaze designs failing to meet the required performance (a 'false path' for one clock cycle) .

Hint 3 – 'read_strobe' can be ignored in most cases and never needs to be part of the multiplexer feeding 'in_port'. However, some functions such as a FIFO buffer do need to know when they have been read and it is in those situations that 'read_strobe' together with a decode of the appropriate value of 'port_id' would be used to generate a "port has been read" pulse to confirm when a read has taken place.

There are 2 clock cycles available to decode the port address 'pp' or '(sY)' and present the requested information to the 'in_port'.

Data captured into 'sX' on this rising clock edge.

OUTPUT sX, pp

OUTPUT sX, (sY)

An 'OUTPUT' instruction is used to transfer information from a register 'sX' to a general purpose output port specified by an 8-bit constant value 'pp' or the contents of another register '(sY)'. KCPSM6 presents the contents of the register 'sX' on 'out_port' and the port address defined by 'pp' or '(sY)' is presented on 'port_id'. Both pieces of information are qualified by an active High ('1') synchronous pulse on the 'write_strobe' pin. Your hardware interface is responsible for capturing the information presented.

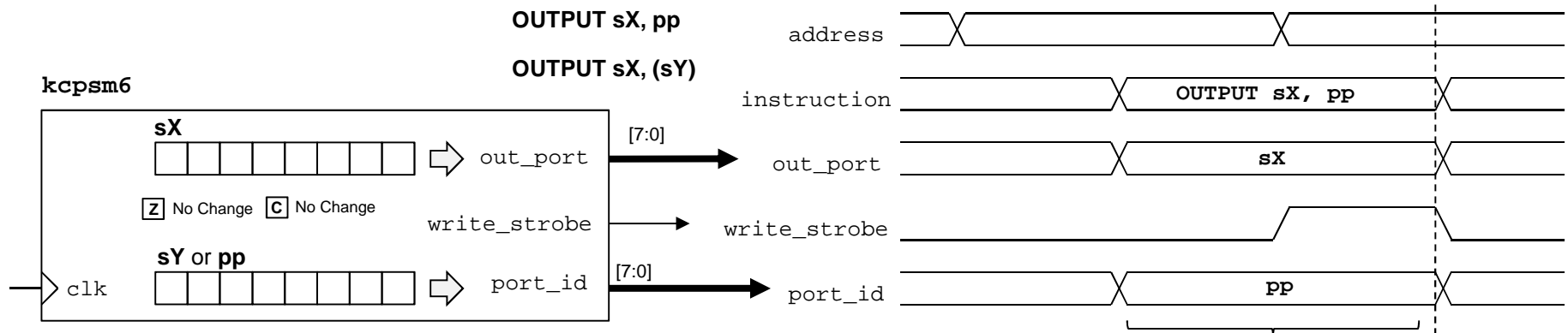

Note that 'out_port' and 'port_id' will vary during the execution of other instructions but 'write_strobe' will only be active during an OUTPUT instruction.

Hint – In most cases a fixed port address 'pp' is used so CONSTANT directives provide an ideal why track your port assignments and make your code easier to write, understand and maintain.

Examples

```
CONSTANT LED_port, 05
;
LOAD s3, 3A
OUTPUT s3, LED_port
```

If you want to keep your designs small and fast then assign port addresses that facilitate smaller logic functions.

In this example a set of 8 LEDs are mapped to port 05 hex and only 3-bits of 'port_id' together with 'write_strobe' are decoded.

```
OUTPUT s6, (s2)
OUTPUT s4, 40
OUTPUT sB, 64'd
```

Decimal values can be used to specify port addresses but hex or binary values are normally easier to work with when defining the hardware.

There are 2 clock cycle available to decode the port address 'pp' or '(sY)'

The value presented on 'out_port' should be captured on the rising edge of the clock when 'write_strobe' is High.

VHDL

```
if clk'event and clk = '1' then
  if write_strobe = '1' then
    if port_id(2 downto 0) = "101" then
      led <= out_port;
    end if;
  end if;
end if;
```

Constant-Optimised Output Ports

In order to understand the motive for the constant-optimised ports and to know when it is better to use them, it is necessary to appreciate the situations in which the general output ports can adversely effect the size of your program code and/or result in lower performance. The 'OUTPUT sX, pp' and 'OUTPUT sX, (sY)' instructions associated with the general purpose output ports both require that the value to be written to the port to be held in a register 'sX'. This is ideal when the value is a variable in your system but when you want to send a constant value, or more likely, a series of constant values to a port the act of loading 'sX' each time increases code size and reduces performance. In many applications this overhead can be tolerated and you should feel no pressure to adapt your design and code to use the constant-optimised ports unless you really want to. However, using constant-optimised ports appropriately can make code easier to write and avoid the code size and performance overhead associated with general purpose output ports when necessary.

Using General Purpose Output ports.....

In this example KCPSM6 is required to write 8-bit data to an external device. The data is naturally variable and is presented to the device interface by outputting to port 20 hex. Then KCPSM6 is required to generate the correct sequence of control signals; 'Dev_write' is set High before a pulse is generated on the 'Dev_clk' followed by 'Dev_write' being returned Low. These signals are controlled by outputting the appropriate sequence of constant values to port 08 hex that define the states of bit0 and bit1.

(This technique of driving control signals is often called 'bit banging').

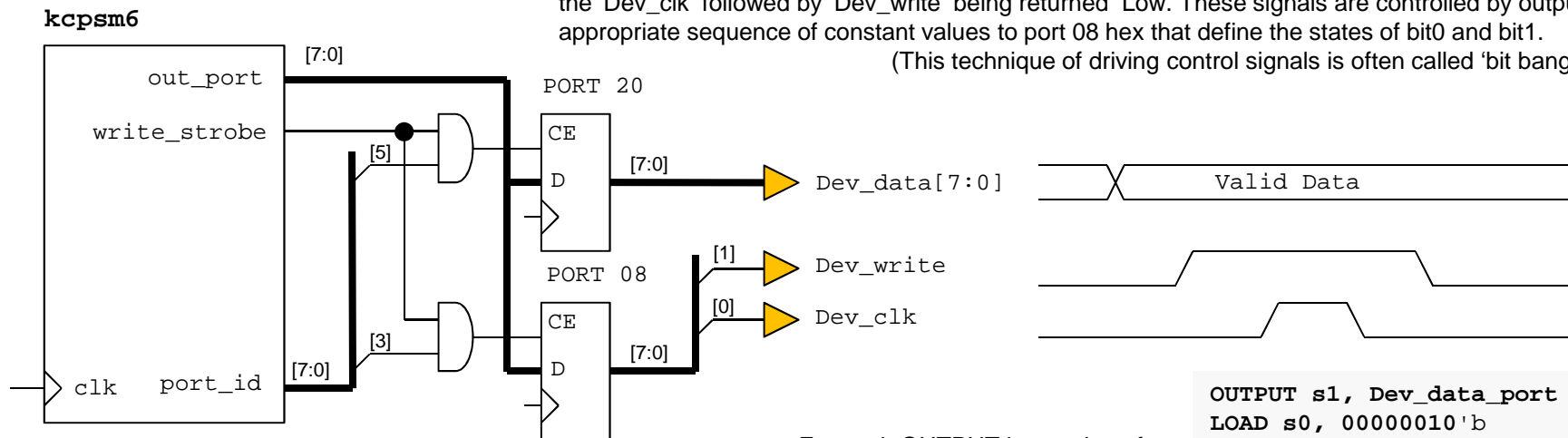

```
CONSTANT Dev_data_port, 20
CONSTANT Dev_control_port, 08
```

For each OUTPUT instruction of the control sequence waveform there is a corresponding LOAD instruction that prepares 's0' with the required constant value.

```
OUTPUT s1, Dev_data_port
LOAD s0, 00000010'b
OUTPUT s0, Dev_control_port
LOAD s0, 00000011'b
OUTPUT s0, Dev_control_port
LOAD s0, 00000010'b
OUTPUT s0, Dev_control_port
LOAD s0, 00
```

Constant-Optimised Output Ports

The timing diagram for the code using the general purpose output ports shows that it takes 16 system clock cycles to generate the control sequence because every instruction takes 2 clock cycles and every OUTPUT instruction requires a corresponding LOAD instruction to initialise 'sX' ('s0' was used in the example). It can also be seen that this results in 4 clock cycles between each transition of the control sequence.

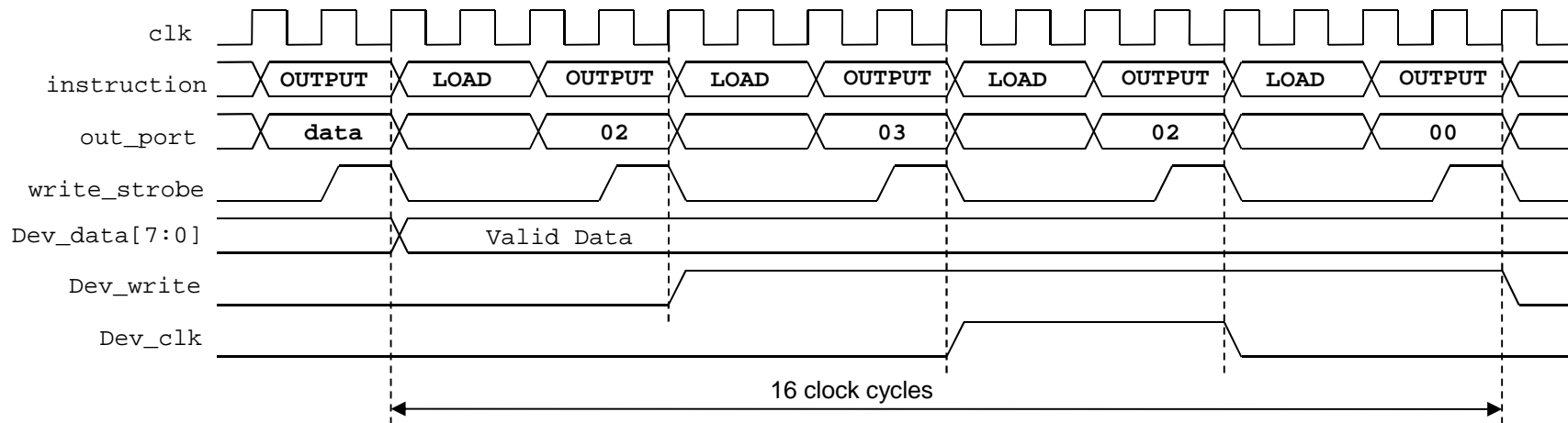

There are a number of applications where it is beneficial that KCPSM6 slows down the generation of waveforms. For example, the communication rate with an SPI Flash memory device may be 33MHz maximum. So if your system clock was 200MHz you would be looking to divide that by at least a factor of 6 and KCPSM6 could help to achieve that naturally. However, if you require higher 'bit banging' performance without just increasing the system clock frequency then clearly there is a limit when using the general purpose output ports.

```
OUTPUT s1, Dev_data_port
LOAD s2, 00000010'b
LOAD s3, 00000011'b
LOAD s0, 00000000'b
OUTPUT s2, Dev_control_port
OUTPUT s3, Dev_control_port
OUTPUT s2, Dev_control_port
OUTPUT s0, Dev_control_port
```

One potential workaround that has been used in KCPSM3 based designs in the past, and is still applicable to KCPSM6 designs, is to reorder your code. As shown on the left, the constant values have been pre-loaded into a set of registers so that the waveform can be generated with a burst of sequential OUTPUT instructions. Whilst this does result in the highest possible 'bit banging' transition rate of the signals during the actual generation of the sequence it also requires more registers to be used and the same amount of time is required to execute the code overall.

Hint – To generate single clock cycle pulses you can use the single clock cycle 'write_strobe' qualified by the 'port_id' rather than set and reset a data bit of a full output port.

Constant-Optimised Output Ports

KCPSM6 provides up to 16 constant-optimised output ports. From a hardware perspective these are used in an identical way to the general purpose output ports except that 'k_write_strobe' is used to qualify the port address which is presented on port_id[3:0]. Hence only port addresses '0' to 'F' (0'd to 15'd) can be used and port_id[7:4] should be ignored. Good optimum designs will allocate output port addresses to minimise the decoding of 'port_id' so this should not pose any challenges.

Returning to the same example of writing data to an external device we can see that port 08 hex has now been allocated to a constant-optimised output port by using the 'k_write_strobe' whilst port 20 hex is still associated with 'write_strobe' because the data is naturally variable. So there is very little difference in the hardware as long as you remember that only port_id[3:0] are defined during an OUTPUTK instruction. Note also that you could now have two different output ports with the same address; one for variable data and the other for constant values (see page 79).

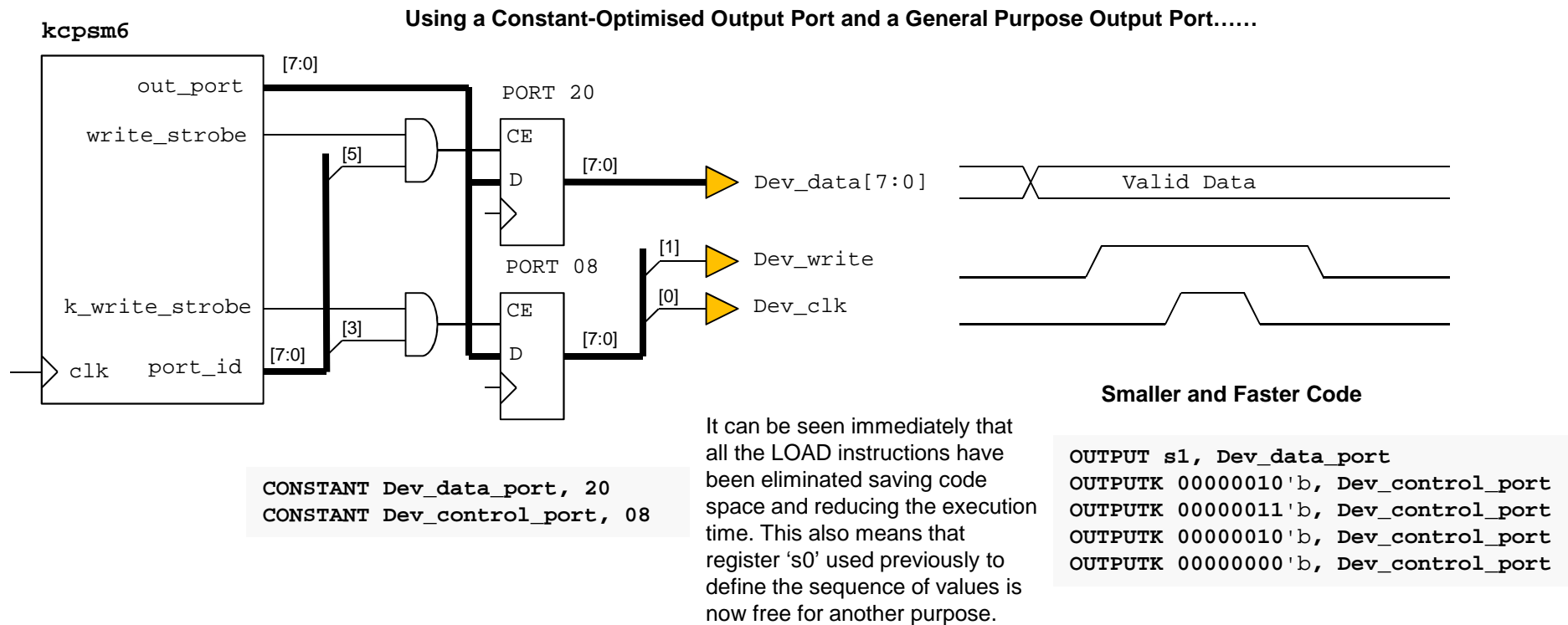

Constant-Optimised Output Ports

OUTPUTK kk, p

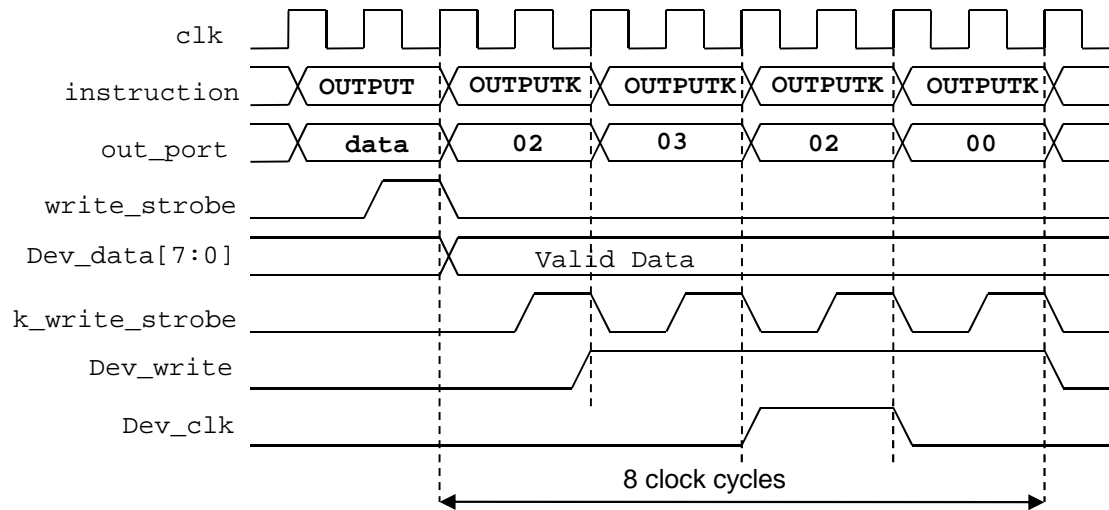

Smaller and Faster Code

```
OUTPUT s1, Dev_data_port
OUTPUTK 0000010'b, Dev_control_port
OUTPUTK 0000011'b, Dev_control_port
OUTPUTK 0000010'b, Dev_control_port
OUTPUTK 0000000'b, Dev_control_port
```

Hint – Using a TABLE directive would also make this code easier to write.

This timing diagram clearly shows the performance advantage when using a constant-optimised output port for a 'bit banging' application. The example control sequence is now completed in 8 rather than 16 clock cycles. More significantly, the standard transition rate is every instruction or 2 system clock cycles. All without the need to use any registers.

OUTPUTK kk, p

The OUTPUTK instruction has two operands. The first operand is the 8-bit constant value 'kk' that will be presented on 'out-port' and therefore must be in the range '00' to 'FF' hex. The second operand must specify the port address that will be presented on port_id[3:0] and therefore must be in the range '0' to 'F' hex. This instruction has no effect on the contents of any registers used or the state of the flags.

Examples

```
CONSTANT token, 61
CONSTANT control_port, 0A

OUTPUTK 61, A
OUTPUTK 97'd, 10'd
OUTPUTK "a", A
OUTPUTK token, control_port
```

These examples show how the KCPSM6 assembler enables the constant and port to be defined and specified in multiple ways. All four 'OUTPUTK' instructions shown are actually the same!

The constant value 'kk' can be specified immediately using hex, decimal or an ASCII character. Alternatively the name allocated to a constant by a CONSTANT directive can be used.

The port address 'p' can also be specified immediately using hex or decimal but remember that this can only be in the range '0' to 'F' (0'd to 15'd). Likewise, the name of constant defined by a CONSTANT directive can be used providing that the value assigned to it also falls within the required range.

Implementing Hybrid Output Ports

Whenever variable data needs to be sent to an output port then a general purpose output port must be used. However, mainly to improve code density the 'OUTPUTK kk, p' instruction is more suitable in some situations so it then becomes desirable to deliver constants to the same port. This can be achieved simply by allocating the same port address (in the range '00' to '0F' hex) to be used by both 'OUTPUT sX, pp' and 'OUTPUTK kk, p' instructions and implementing a hybrid port in hardware.

An example of a hybrid port is shown below. In this case KCPSM6 is required to send information to a UART transmitter to be observed on a PC terminal. Not surprisingly, the information will be a series of ASCII characters but many of these will be pre-defined strings or constants whilst others will represent the variable data to be displayed. This example also illustrates a possible use of the 'sleep' control and the 'STRING' directive in the KCPSM6 assembler.

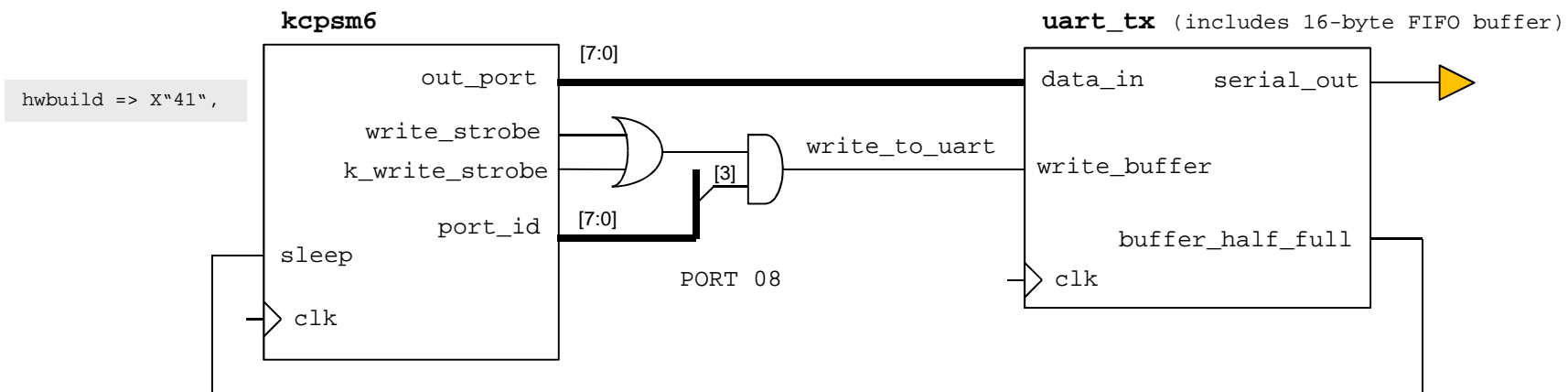

Hybrid port decode in VHDL

```
write_to_uart <= (k_write_strobe or write_strobe) and port_id(3);
```

In order to create a hybrid port the port address must be in the range '00' to '0F' hex and in this example 08 hex has been used in a optimised decode of 'port_id' (i.e. only port_id[3] is actually being observed to minimise the logic function performing the decode). Then both 'write_strobe' and 'k_write_strobe' are used to qualify the port address so that either an 'OUTPUT sX, 08' or an 'OUTPUT kk, 8' instruction will result in data being written to the FIFO buffer within the UART transmitter macro.

The circuit diagram also shows how the 'half full' status output from the FIFO buffer could be used to make KCPSM6 wait (sleep) each time the buffer starts to fill up and this hardware form of handshaking is important if code density is to be achieved as we will see on the next page....

Implementing Hybrid Output Ports & Text Strings

PSM file

```
CONSTANT UART_Tx_port, 08
;
STRING hw_intro$, "Hardware Build: "
OUTPUTK hw_intro$, UART_Tx_port
HWBUILD s0
OUTPUT s0, UART_Tx_port
OUTPUTK 0D, UART_Tx_port
```



LOG file

```
000 2B488 OUTPUTK 48[hw_intro$: "H"], 8[UART_Tx_port]
001 2B618 OUTPUTK 61[hw_intro$: "a"], 8[UART_Tx_port]
002 2B728 OUTPUTK 72[hw_intro$: "r"], 8[UART_Tx_port]
003 2B648 OUTPUTK 64[hw_intro$: "d"], 8[UART_Tx_port]
004 2B778 OUTPUTK 77[hw_intro$: "w"], 8[UART_Tx_port]
005 2B618 OUTPUTK 61[hw_intro$: "a"], 8[UART_Tx_port]
006 2B728 OUTPUTK 72[hw_intro$: "r"], 8[UART_Tx_port]
007 2B658 OUTPUTK 65[hw_intro$: "e"], 8[UART_Tx_port]
008 2B208 OUTPUTK 20[hw_intro$: " "], 8[UART_Tx_port]
009 2B428 OUTPUTK 42[hw_intro$: "B"], 8[UART_Tx_port]
00A 2B758 OUTPUTK 75[hw_intro$: "u"], 8[UART_Tx_port]
00B 2B698 OUTPUTK 69[hw_intro$: "i"], 8[UART_Tx_port]
00C 2B6C8 OUTPUTK 6C[hw_intro$: "l"], 8[UART_Tx_port]
00D 2B648 OUTPUTK 64[hw_intro$: "d"], 8[UART_Tx_port]
00E 2B3A8 OUTPUTK 3A[hw_intro$: ":"], 8[UART_Tx_port]
00F 2B208 OUTPUTK 20[hw_intro$: " "], 8[UART_Tx_port]
010 14080 HWBUILD s0
011 2D008 OUTPUT s0, 08[UART_Tx_port]
012 2B0D8 OUTPUTK 0D, 8[UART_Tx_port]
```

This code uses the hybrid port to display the hardware build state on the PC terminal display.

```
Hardware Build: A
```

The code exploits the STRING directive to describe the sequence of 16 constant values required to send 'Hardware Build: ' to the UART using 'OUTPUTK' instructions. It then loads 's0' with the 'hwbuild' value defined as 41 hex (character "A") using the KCPSM6 generic (see pages 34 and 100) which it sends to the UART using an 'OUTPUT' instruction. The communication is completed by sending a carriage return (0D hex) using an 'OUTPUTK' instruction.

The LOG file shows how the text string has been used to expand the code into multiple 'OUTPUTK' instructions. Under normal operating conditions the complete 19 instruction sequence will execute in just 38 system clock cycles. It is therefore vital that whatever you are sending data to has the capability of receiving information at that speed. In this example the UART transmitter only has a 16 character FIFO buffer so hardware handshaking exploiting the 'sleep' control is the solution. An alternative would be to have a larger FIFO buffer and to be sure it had adequate free space before starting to send the characters (i.e. test for FIFO empty state prior to sending the burst of information).

Note that if you were to implement a software based check of the FIFO status by reading an input port then you would increase the code to the same size as it would be if you only used a general purpose output port. Therefore hardware handshaking schemes using 'sleep' or interrupts are the key to slowing down 'OUTPUTK' sequences if code density is the key objective.

```
CALL test_FIFO_full
OUTPUTK "H", 8
CALL test_FIFO_full
OUTPUTK "a", 8
```

```
LOAD s1, "H"
CALL send_to_UART
LOAD s1, "a"
CALL send_to_UART
```

Hint – Look also at string support using 'LOAD&RETURN' (page 99) and TABLE directive (page 100).

Hint – Also look at 'all_kcpsm6_syntax.psm'.

STORE sX, ss

STORE sX, (sY)

The store instructions write the contents of a register 'sX' into the scratch pad memory (SPM). The location (or address) within the SPM into which the register contents are written can be defined by a specific address 'ss' or by the contents of a second register '(sY)'. The contents of the register and the states of the zero and carry flags are not effected by the operation.

The default setting of KCPSM6 provides 64-bytes of scratch pad memory with locations 00 to 3F hex (0'd to 63'd). If more memory is required then the 'scratch_pad_memory_size' generic can be set to '128' or '256' to increase the size to 128-bytes (locations 00 to 7F) or 256 bytes (locations 00 to FF). It is your responsibility to ensure that you only write to locations that physically exist.

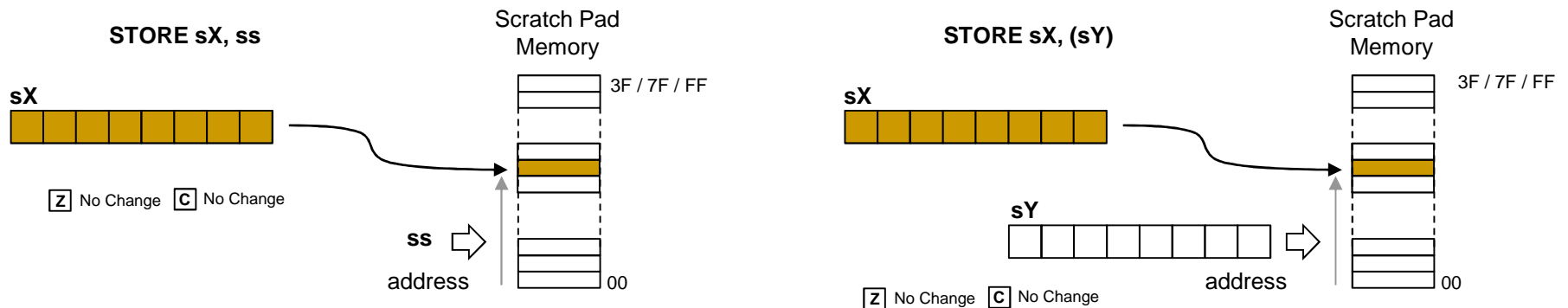

Examples

```
CONSTANT status, 12'd
CONSTANT buffer_start, 30
```

Hint – The CONSTANT directive can be used to assign meaningful names to specific locations. The constants defined in this example are then used in the code examples below

```
INPUT s0, system_state
AND s0, 1F
STORE s0, status
```

The status of a system is read from a port and after the 5 least significant bits have been isolated the value is stored in a SPM location 0C (12'd).

```
LOAD s1, buffer_start
read8: INPUT s0, data_in
STORE s0, (s1)
ADD s1, 01
COMPARE s1, 38
JUMP NZ, read8
```

With 's1' acting as a memory pointer and counter, this code reads 8 bytes of data from a port and stored it in a buffer formed of SPM locations 30 to 37 hex.

Fact – If you do write to a location larger than the size of the scratch pad memory available then the location specified in the STORE instruction will alias down into the active range and write the information at that location. For example, if 'STORE s3, 5A ' is executed when the size of memory is 64 bytes then the contents of 's3' will be written to location 2A hex (5A = 0101 1010 but only the lower 6-bits are used to address up to 64 locations and 10 1010 = 2A).

FETCH sX, ss

FETCH sX, (sY)

The fetch instructions read the contents of a location of scratch pad memory (SPM) into a register 'sX' into The SPM location (or address) to be read can be defined by a specific address 'ss' or by the contents of a second register '(sY)'. The contents of the SPM and the states of the zero and carry flags are not effected by the operation.

The default setting of KCPSM6 provides 64-bytes of scratch pad memory with locations 00 to 3F hex (0'd to 63'd). If more memory is required then the 'scratch_pad_memory_size' generic can be set to '128' or '256' to increase the size to 128-bytes (locations 00 to 7F) or 256 bytes (locations 00 to FF). It is your responsibility to ensure that you only read locations that physically exist.

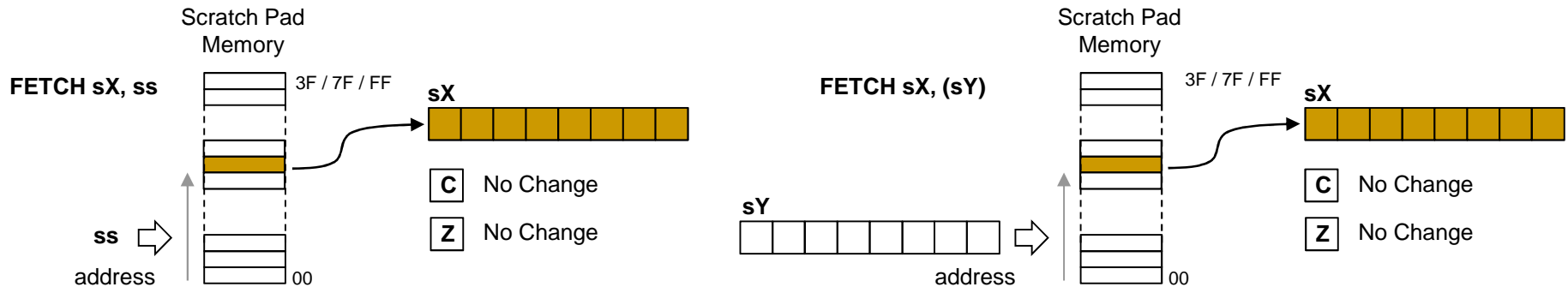

Examples

```
CONSTANT status, 12'd
CONSTANT buffer_start, 30
```

Hint – The CONSTANT directive can be used to assign meaningful names to specific locations. The constants defined in this example are then used in the code examples below

```
FETCH s0, status
AND s0, 02
SR0 s0
OUTPUT s0, ok_port
```

Bit1 of the status stored in SPM location 0C (12'd) is isolated and used to set bit0 of output 'ok_port'. Note how the full status information remains unchanged in the SPM.

```
LOAD s2, 00
LOAD s1, buffer_start
chksum8: FETCH s0, (s1)
ADD s2, s0
ADD s1, 01
COMPARE s1, 38
JUMP NZ, chksum8
```

With 's1' acting as a memory pointer and counter, this code reads the 8 bytes of data stored in SPM locations 30 to 37 hex and adds them together (ignoring any overflow) to form a checksum value in 's2'.

Fact – If you do read from a location larger than the size of the scratch pad memory available then the location specified in the FETCH instruction will alias down into the active range and read information from that location. For example, if 'FETCH s3, 5A ' is executed when the size of memory is 64 bytes then 's3' will be loaded with the contents of SPM location 2A hex (5A = 0101 1010 but only the lower 6-bits are used to address up to 64 locations and 10 1010 = 2A).

ENABLE INTERRUPT

DISABLE INTERRUPT

See also pages 40-44

These instructions are used to control when interrupts are allowed to happen. Following device configuration or the application of a reset to the KCPSM6 macro the program starts executing from address zero and interrupts are disabled. Quite simply, this means that a High level on the 'interrupt' input will be ignored. The 'ENABLE INTERRUPT' instruction is used to enable interrupts by setting the interrupt enable flag (IE = 1). Hence this instruction need to be included at a suitable point in your code to activate the 'interrupt' input such that KCPSM6 will react to an interrupt request. 'ENABLE INTERRUPT' has no other effects.

INTERRUPT ENABLE

IE ← '1'

Z

No Change

C

No Change

Important – You should never execute an 'ENABLE INTERRUPT' within your ISR (i.e. anywhere between the interrupt vector and the RETURNI instruction). Once one interrupt can be serviced at a time and if you re-enable interrupts before the end of the ISR then there is every risk that another interrupt may occur.

The 'DISABLE INTERRUPT' instruction is used to disable interrupts by clearing the interrupt enable flag (IE = 0). This would typically be used to temporarily avoid the execution of critical section of code from being interrupted. 'DISABLE INTERRUPT' has no other effects.

DISABLE INTERRUPT

IE ← '0'

Z

No Change

C

No Change

Hint – It is considered good coding practice if these instructions are only executed when actually modify the state of the interrupt enable flag. Whilst it does not cause a problem to execute the instruction in a way that confirms the state (e.g. using 'ENABLE INTERRUPT' when IE is already '1') such a coding style makes it less clear at what points you in your code interrupts are enabled and disabled and this can lead to confusion when debugging in the long term.

Examples

```
TEST s6, 02
JUMP NZ, no_pulse
DISABLE INTERRUPT
OUTPUTK 01, trigger_port
LOAD s0, s0
LOAD s0, s0
OUTPUTK 00, trigger_port
ENABLE INTERRUPT
no_pulse: LOAD s3, JUMP Z,
```

This section of code is taken from a program at a point when interrupts are enabled and therefore subject to interruption at any time that the interrupt input is driven High.

The state of Bit1 of register 's6' is tested and if it is High then a pulse is generated on Bit0 of 'trigger_port'. A pair of 'LOAD s0, s0' instructions are used to stretch the pulse to be exactly 6 clock cycles in duration (3 instructions).

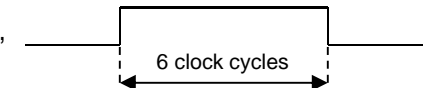

If an interrupt were to occur whilst generating the pulse then its duration could be increased considerably and in this case that was unacceptable. So to ensure that the pulse would always be 6 clock cycles interrupts are temporarily disabled only whilst the time critical is executed.

Another example would be to temporarily disable interrupts whilst the main program reads information from scratch pad memory where that information is updated by the ISR. This would ensure that the information read is a complete set and not a mixture of the information resulting from 2 separate interrupts.

RETURNI ENABLE

RETURNI DISABLE

See also pages 40-44

When an interrupt occurs the program counter is loaded with the interrupt vector and the current address (corresponding with the location of the instruction that is abandoned) is pushed onto the stack. In addition the states of the carry flag (C), the zero flag (Z) and the register bank selection are also pushed onto the stack and further interrupts automatically disabled (IE = 0).

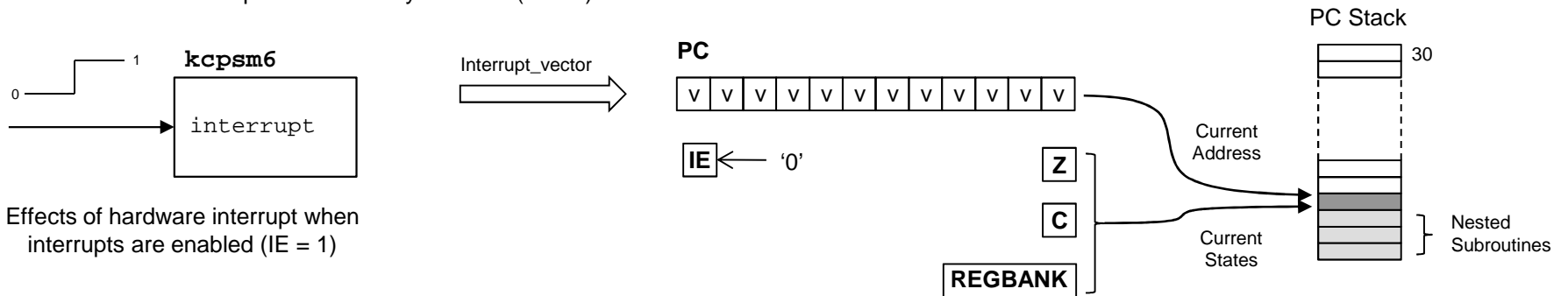

The 'RETURNI' instruction is similar to the unconditional 'RETURN' instruction *but it must only be used to terminate an interrupt service routine (ISR)*. When the 'RETURNI' is executed the last address held on the PC Stack is popped off and loaded directly into the program counter so that the program resumes execution starting with the instruction that was abandoned when the interrupt occurred. In addition, the RETURNI restores the values of the carry flag (C), the zero flag (Z) and the register bank selection so that they are exactly the same as when the interrupt occurred. Either the 'ENABLE' or 'DISABLED' operand must be used to specify if interrupts are to be enabled or disabled on return from the ISR.

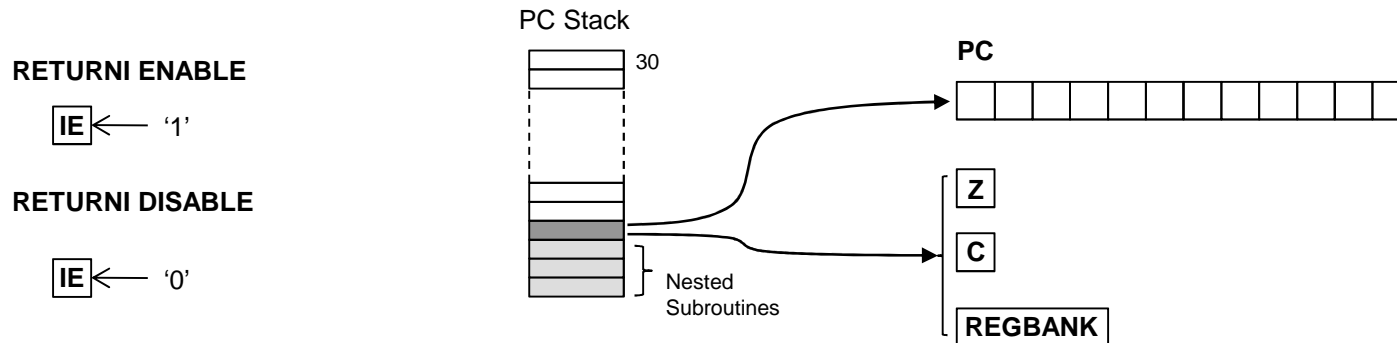

Continued on next page....

RETURNI ENABLE

RETURNI DISABLE

See also pages 40-44

Important 1 – Always terminate an ISR with a 'RETURNI' and always terminate a normal subroutine with 'RETURN'. The execution of the inappropriate instruction will result in incorrect operation. Obviously that would be bad enough, but combined with the whole concept of interrupts occurring at any point in the execution of the main code the symptoms of the incorrect operation failure can be subtle and make it extremely difficult to identify the cause.

Important 2 – Just as each 'RETURN' must be executed to correspond with the 'CALL' that invoked a normal subroutine, a 'RETURNI' must only be executed to correspond with the interrupt that invoked the ISR. Your ISR can exploit KCPSM6's ability to implement nested subroutines just as they can be used in any part of your program but it is vital that each level is invoked and completed in order. The maximum number of levels is 30 and it should be remembered that an interrupt requires one of these levels. If an interrupt does result in a stack overflow then KCPSM6 will automatically generate an internal reset. Likewise if RETURNI used in a way that results in a stack underflow then KCPSM6 will also reset itself automatically.

Examples

```
ISR: ADD sE, 1'd
      ADDCY sF, 0'd
      RETURNI ENABLE
```

This simple ISR increments the 16-bit value contained in the register pair [sF, sE]. This may relate to a scheme in which interrupts occur at regular intervals to provide the base for a real time clock or timer (i.e. the value held in [SF,sE] is then used by the main program when required). The 'RETURNI ENABLE' instruction terminates the ISR and enables interrupts ready for the next time.

```
ISR: INPUT sF, int_data0
      STORE sF, 2A
      INPUT sF, int_data1
      STORE sF, 2B
      LOAD sE, 2A
      RETURNI DISABLE
```

This ISR reads two bytes of information from input ports and stores them in scratch pad memory. It is reasonable to assume that this information relates in some way to the reason for the interrupt and therefore probably represents some important information that had to be captured at that particular time. It can also be imagined that the main program needs to process this special information in some way with the value '2A' loaded into register 'sE' signifying that information has been captured and stored starting at location 2A hex. It can be imagined that the main program must be given time to process the captured information so the 'RETURNI DISABLE' instruction terminates the ISR but prevents a further interrupts overwriting the important information before it has been used. The main program would use an 'ENABLE INTERRUPT' once it had.

```
ISR: LOAD sA 00
      CALL motor_drive
      RETURNI ENABLE
```

Providing all the normal rules of nested subroutines are followed then an ISR can also make use of subroutines.

```
motor_drive: OUTPUT sA, PWM_value
              OUTPUTK 01, update_strobe
              OUTPUTK 00, update_strobe
              RETURN
```

Hint – Be very careful to make sure that no code executed as part of your ISR procedure contains an 'ENABLE INTERRUPT' instruction.

Interrupts and Register Banks

Although both banks of registers can be exploited at any time, the option to reserve at least some of the registers in the second bank of registers for use in the ISR is very compelling as this guarantees that no undesirable changes are made to the contents of registers used by the main program that has been interrupted. This example illustrates two situations in which an interrupt could occur and how 'RETURNI' always restores the correct register bank.

ENABLE INTERRUPT

```
loop: LOAD sA, 00
      ↓
      LOAD sE, FF
wait: SUB sE, 01
      JUMP NZ, wait
```

If an interrupt occurs in this loop which is decrementing 'sE' until it reaches zero then it is important that the interrupt service routine (ISR) does not corrupt the value held in 'sE'. So in this case the ISR has switched to register bank 'B' where it implements a 16-bit interrupt counter using registers [sF, sE]. safe in the knowledge that 'sE' in bank 'A' is preserved.

```
COMPARE sA, 01
JUMP Z, post_int_action
```

```
LOAD s4, 19
LOAD s5, 1C
CALL mult
```

```
JUMP loop
```

```
mult: REGBANK B
      LOAD s3, 8'd
      SR0 s4
      ↓
      REGBANK A
      RETURN
```

The main program calls a 'mult' subroutine which also temporarily uses register bank 'B'.

Hint - STAR can be used to pass some information from the ISR to the main program.

RETURNI automatically ensures that the states of flags and the register bank are restored to their values prior to the interrupt. In this case bank 'B' is retained at the end of the ISR as that was the active bank when the interrupt occurred.

RETURNI automatically restores the states of the 'C' and 'Z' flags to the values they had when the interrupt occurs. RETURNI also select the register bank that was active prior to the interrupt which in this case restores the default bank 'A'.

```
ADDRESS 3D0
ISR: REGBANK B
      ↓
      ADD sE, 1'd
      ADDCY sF, 00
      ↓
      LOAD sC, 01
      STAR sA, sC
      ↓
      RETURNI ENABLE
```

If an interrupt occurs whilst in this subroutine then bank 'B' is already active so the 'REGBANK B' at the start of the ISR doesn't change anything and the ISR must be written carefully not to disturb the registers used by the 'mult' subroutine.

JUMP aaa

'JUMP aaa' is an unconditional JUMP which forces the program counter (PC) to the absolute address defined by the value 'aaa'. Following power up or a reset KCPSM6 executes code starting at address zero and in general the address increments as each instruction is executed. The unconditional JUMP instruction forces the address to a new value and hence directs KCPSM6 to deviate from the normal incrementing sequence. A JUMP instruction has no effect on any other features within KCPSM6 including the states of the flags.

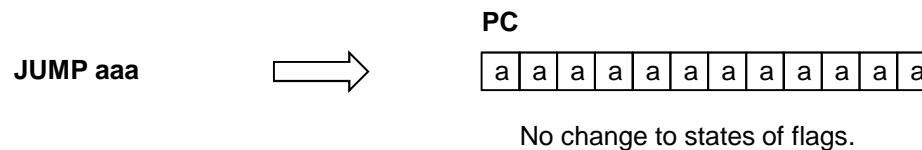

'aaa' represents a 12-bit address with the range 000 to FFF hex (0'd to 4095'd). However, in nearly all cases it is the assembler which resolves the actual value of the address based on the line labels you include in your program code so you don't have to think about this yourself. Therefore it could be said that the format of the instruction is normally 'JUMP <line_label>'.

Whilst the address range supports programs up to 4K instructions the physical size of the program memory is defined by your hardware. Obviously the larger the program memory, the more block memories (BRAMs) are consumed within the device so the typical methodology is to start with the smallest memory of 1K (address range 000 to 3FF) requiring only a single in a Spartan-6 device and then only to increase the size of the memory if the program outgrows it. It is your responsibility to ensure that the program can fit within the physical address range available but since the assembler resolves most addresses from line labels for you and reports the highest occupied address for your program this is rarely an issue.

Example

```
cold_start: LOAD s0, 27
            STORE s0, status
            ...

warm_start: FETCH s0, status
            OUTPUT s0, LED_port
            CALL update_status
            ...

            JUMP warm_start
```

Nearly all programs include code that is repeatedly executed. These excerpts of a typical program illustrate how a program generally begins with some initialisation tasks that are only performed on power up or following a hardware reset and then the main program code that repeats. The unconditional JUMP forced the execution to loop back to the start of the main program.

The assembler resolves the line label 'warm_start' into an actual address value which you can see in the LOG file if you are interested.

LOG file shows resolved address...

```
32C 2202B JUMP 02B[warm_start]
```

Hint – The example on the right forces KCPSM6 to stop at the current address. This may seem pointless but a reset or an interrupt can override this and makes KCPSM6 resume a normal execution flow. This technique can be a useful during development and testing of both hardware and software.

```
Halt: JUMP Halt
```

JUMP Z, aaa

JUMP C, aaa

JUMP NZ, aaa

JUMP NC, aaa

These four conditional JUMP instructions force the program counter (PC) to the absolute address defined by the value 'aaa' providing that either the carry flag (C) or the zero flag (Z) is the state specified. If the condition is false the program counter will increment the address and advance to the next instruction. A conditional JUMP instruction has no effect on any other features within KCPSM6 including the states of the flags. See also description of 'JUMP aaa'.

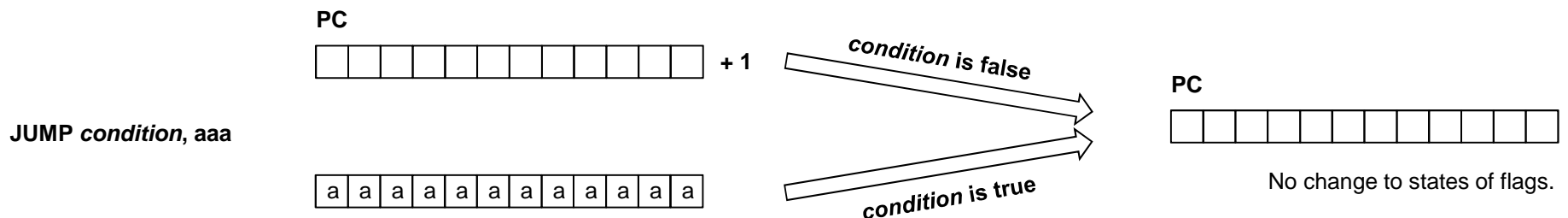

- JUMP Z, aaa** JUMP to address 'aaa' if the zero flag is set otherwise advance to next instruction.
- JUMP NZ, aaa** JUMP to address 'aaa' if the zero flag is not set otherwise advance to next instruction.
- JUMP C, aaa** JUMP to address 'aaa' if the carry flag is set otherwise advance to next instruction.
- JUMP NC, aaa** JUMP to address 'aaa' if the carry flag is not set otherwise advance to next instruction.

Examples

```
INPUT s0, uart_rx_data
COMPARE s0, "R"
JUMP Z, read_process
COMPARE s0, "W"
JUMP Z, write_process
```

An ASCII character is read from a UART and this is first compared with the letter 'R'. If the ASCII value is the same then the zero flag is set and hence the flow of the program will transfer to the address associated with the label 'read_process'. If the character does not match then the program continues and performs a similar comparison with the letter 'W' to decide if 'write_process' should be executed.

```
LOAD s0, 25'd
delay100: SUB s0, 1'd
JUMP NZ, delay100
```

The value contained in 's0' is repeatedly decremented until it reaches zero forming a delay of 100 clock cycles (25 x 2 instructions x 2 clock_cycles). The state of the zero flag is determined by the result of the 'SUB' instruction so until the value in 's0' reaches zero the state of the zero flag is not-zero (NZ) so the loop is repeated.

```
TEST sB, FF
JUMP C, odd_parity
AND sB, 7F
```

The parity of the 8-bit value contained in 'sB' is tested and if it is odd a jump is made to the code located at 'odd_parity'. When even parity the 'AND sB, 7F' instruction is executed.

```
shift: SR1 s3
JUMP NC, shift
```

Shifts 's3' to the right until a '1' in the least significant bit is shifted into the carry flag.

JUMP@ (sX, sY)

The 'JUMP@ (sX, sY)' is an unconditional JUMP which forces the program counter (PC) to the address defined by the contents of the 'sX' and 'sY' registers.

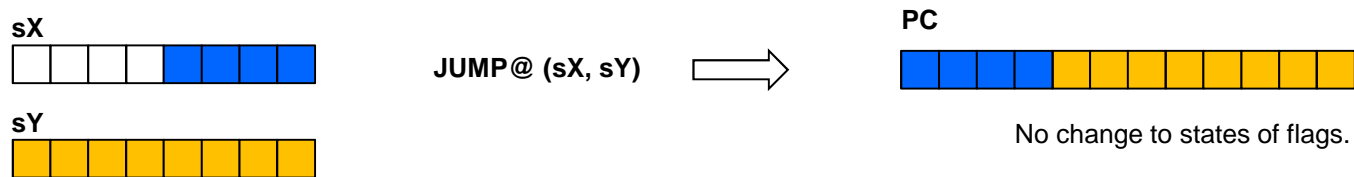

The 12-bit address is formed of the lower 4-bits of the 'sX' register and all 8-bits of the 'sY' register. The upper 4-bits of 'sX' are ignored and the contents of both registers are unaffected by the operation. There is no restriction on which registers can be used but it would be common coding practice to assign an adjacent pair such as 'sB' and 'sA'.

Since the destination address is defined by the contents of the registers this is powerful instruction but also has the potential to be dangerous! You are entirely responsible for writing a program in which the computed address presented by the pair of registers corresponds with a valid location within your physical program space. The KCPSM6 assembler can do nothing to prevent you computing an inappropriate address but it does provide a mechanism to enable you to determine the addresses associated with line labels as shown in the following example.

Example This example assumes that a user selects an option from a menu by providing a numerical ASCII character in the range "1" to "4" (this range could easily be extended). The program reads this character, converts it to a value in the range 0 to 3 and then jumps to the appropriate routine of 'choice'.

```
LOAD sB, menu'upper
LOAD sA, menu'lower
INPUT s0, selection_port
SUB s0, "1"
ADD sA, s0
ADDCY sB, 00
JUMP@ (sB, sA)
menu: JUMP choice1
      JUMP choice2
      JUMP choice3
      JUMP choice4
```

Without the 'JUMP@' instruction the menu would be implemented by a sequential series of compare and jumps (as shown on the right) which does not scale very well but is suitable when there is a small number of choices. Using the 'JUMP@' can help when there are lots of choices and also means that the execution time is the same regardless of the selection being made.

The KCPSM6 assembler provides 'upper and 'lower attributes that can be used with labels to define the 8-bit constants to be loaded into the registers. These abstracts of the LOG file show how the upper and lower parts of the address are resolved into 'kk' values.

Hint - The 'upper and 'lower attributes can also be used to derive 'kk' values for use in other instructions Such as 'ADD sX, kk' or 'COMPARE sX, kk'.

```
INPUT s0, selection_port
COMPARE s0, "1"
JUMP Z, choice1
COMPARE s0, "2"
JUMP Z, choice2
COMPARE s0, "3"
JUMP Z, choice3
COMPARE s0, "4"
JUMP Z, choice4
```

```
7B4 01B07 LOAD sB, 07[menu'upper]
7B5 01ABB LOAD sA, BB[menu'lower]
```

```
7BB 22862 menu: JUMP 862[choice1]
```

Subroutines

Subroutines are sections of code that are written to perform certain tasks which are then called (invoked) from another section of code. The key point about a subroutine is that it can be called from anywhere within a program and the processor will return to that point in the code when the subroutine's task is complete. This means that it is possible to call the same subroutine from different places within a program because the processor knows which place to return to on each occasion.

An analogy is like you watching a film on DVD and pressing the pause playback button whilst you make a telephone call. Once you have completed your phone call you return to the DVD and press play button to resume the film from the point that you left it. A little later you need to make another phone call so pause the film again whilst you make that call. Once complete you return to the film to continue the film from the point you left it the second time. In this case the DVD player had remembered where you had paused the film so that each time you returned from making a phone call it resumed playback from the point that you had left it. Making a phone call was effectively a 'subroutine' that you invoked whilst pausing the main task of watching the film.

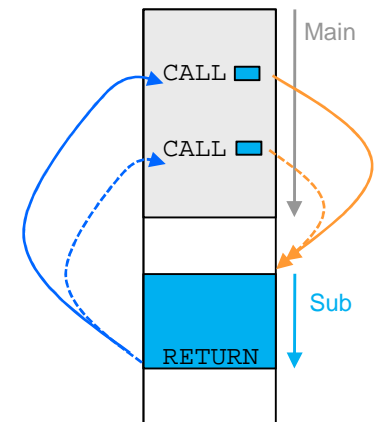

Reasons for using subroutines.

Common tasks – When the same task needs to be performed at several different places within a program then it is more code efficient to describe it once in a subroutine than replicate in each place that it is required.

Tidy code – By placing the details of particular tasks into subroutines your main code becomes more compact and easier to write/understand.

Code development and Maintenance – A subroutine can be developed and tested in relative isolation until it provides the desired functionality. With good definition of registers, memory locations and ports used by a subroutine the main program will know the 'interface' when calling it and can have a high degree of certainty that it will perform the task expected without unexpected disturbance to register contents etc. As always, the inclusion of accurate and meaningful comments in your code will always be rewarded in the long term.

Library of common tasks – Depending on the application and product there will often be functions that are replicated within a system or carried forward from one generation to the next. These functions will often be specific to your products but they will still be 'common' tasks to you. Well defined and described subroutines make it very easy to copy these functions from a known working design and paste them into your other designs saving time and effort.

Interrupt handling – A hardware driven interrupt is a special case but uses the same mechanism which effectively calls a special subroutine commonly known as an interrupt service routine (ISR) which then returns to the main program at the point at which it was interrupted. This is described in more detail in the interrupt section.

KCPSM6 support for Subroutines

KCPSM6 provides 'CALL' and 'RETURN' instructions which work with a fully automatic program counter stack which it used to remember the location (address) associated with each 'CALL' used to invoke a subroutine in order that it can return to that location when a 'RETURN' instruction is executed to terminate the subroutine. There is no requirement for you to reserve any memory, set up any stack pointers or implement any special code, KCPSM6 will do everything for you.

Nested subroutine support

Nested subroutine refers to the ability to call a subroutine whilst already executing another subroutine. The program counter stack within KCPSM6 actually has the ability to support nested subroutine calls to a maximum of 30 levels. Given that it is unusual for a program to exceed 8 levels of nested subroutine calls at one time the 30 levels supported by KCPSM6 provides you with significant freedom when writing your code without the worry of reaching the limit.

It should be remembered that an interrupt is a special case which also uses a level as the ISR is invoked but with 30 levels available even the ISR could include nested subroutine calls of its own.

Your code must be right!

Whilst the PC Stack is completely dedicated and automatic you are entirely responsible for making sure that for each CALL made to a subroutine you have a *corresponding* RETURN which completes it. You need to ensure that each CALL and RETURN is a related pair. As the term 'nesting' implies, each CALL starts a new level and each RETURN terminates a level in the reverse order. In practice this is all very logical and intuitive providing you truly understand the concept and the diagram on the right.

Hint – Although this diagram shows each subroutine located below the other your subroutines can be arranged in any order within the program space and there are absolutely no restrictions on which order in which they can be called. The only thing you need to ensure that a subroutine is only executed by being called otherwise it will encounter a RETURN that did not have a corresponding CALL.

Built-in Protection

In the unlikely event that execution of a CALL instruction or an interrupt does result in a stack overflow then KCPSM6 will automatically reset. Whilst this is rather dramatic it is predictable when compared with the alternative of incorrect code execution. In practice, the main reason for this ever happening is incorrect PSM code where the CALL and RETURN instructions do not correspond. A typical coding error is the use of a JUMP back to a main program instead of a RETURN which can appear to work correctly until the CALL without a corresponding RETURN has executed nearly 30 times leaving inadequate levels for even the correct subroutines. Likewise, if incorrect coding leads to the execution of a RETURN or RETURNI instruction that results in a stack underflow then KCPSM6 will also automatically generate an internal reset.

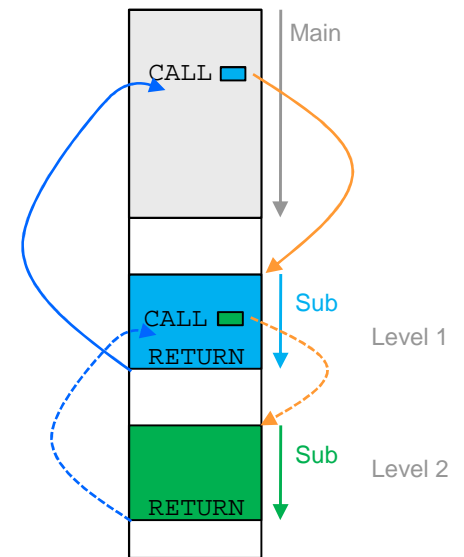

CALL aaa

'CALL aaa' is an unconditional CALL to a subroutine which pushes the current contents of the program counter (PC) onto the stack and loads the PC with the address defined by the value 'aaa'. A subroutine should end with a 'RETURN' instruction which will pop the last pushed address off of the stack, increment it and load it back into the program counter such that the program then executes the instruction following the initial CALL. Please also see the description of 'JUMP aaa' regarding the valid range of 'aaa' values and how the assembler is typically used to resolve their values for you.

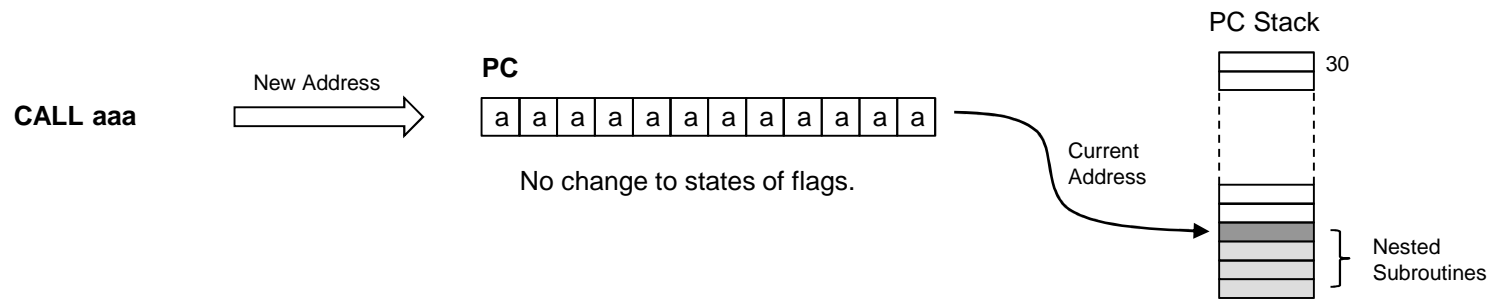

Whist the PC Stack is completely dedicated and automatic you are entirely responsible for making sure that for each CALL made to a subroutine you have a *corresponding* RETURN. You must also ensure that execution of your program does not exceed 30 'nested' subroutines but this limit is rarely challenged by typical programs. Remember that an interrupt is a special case equivalent to a call and will use one level. If the stack does overflow then KCPSM6 will automatically reset.

Example Within some code a CALL is made to a subroutine called 'inc_count' which contains a 12-instruction procedure that increments a 32-bit number stored in 4 bytes of scratch pad memory. The corresponding RETURN at the end of the subroutine allows the program to continue.

```
AND s0, 01
OUTPUT s0, status
CALL inc_count32
LOAD s0, 38
JUMP main_loop
```

```
inc_count32: FETCH s0, count0
             FETCH s1, count1
             FETCH s2, count2
             FETCH s3, count3
             ADD s0, 1'd
             ADDCY s1, 00
             ADDCY s2, 00
             ADDCY s3, 00
             STORE s0, count0
             STORE s1, count1
             STORE s2, count2
             STORE s3, count3
             RETURN
```

Hint – A subroutine can be located anywhere in a program relative to the CALL instructions that invoke it but it is vital that the subroutine is only executed as the result of a CALL otherwise there will be no address in the PC stack to correspond with the subsequent RETURN instruction.

CALL Z, aaa

CALL C, aaa

CALL NZ, aaa

CALL NC, aaa

These four conditional CALL instructions invoke a subroutine located at 'aaa' providing that either the carry flag (C) or the zero flag (Z) is the state specified. If the condition is false the program counter will increment the address and advance directly to the next instruction. A conditional CALL instruction has no effect on any other features within KCPSM6 including the states of the flags. See also description of 'CALL aaa'.

- CALL Z, aaa** Call address 'aaa' if the zero flag is set otherwise advance to next instruction.
- CALL NZ, aaa** Call address 'aaa' if the zero flag is not set otherwise advance to next instruction.
- CALL C, aaa** Call address 'aaa' if the carry flag is set otherwise advance to next instruction.
- CALL NC, aaa** Call address 'aaa' if the carry flag is not set otherwise advance to next instruction.

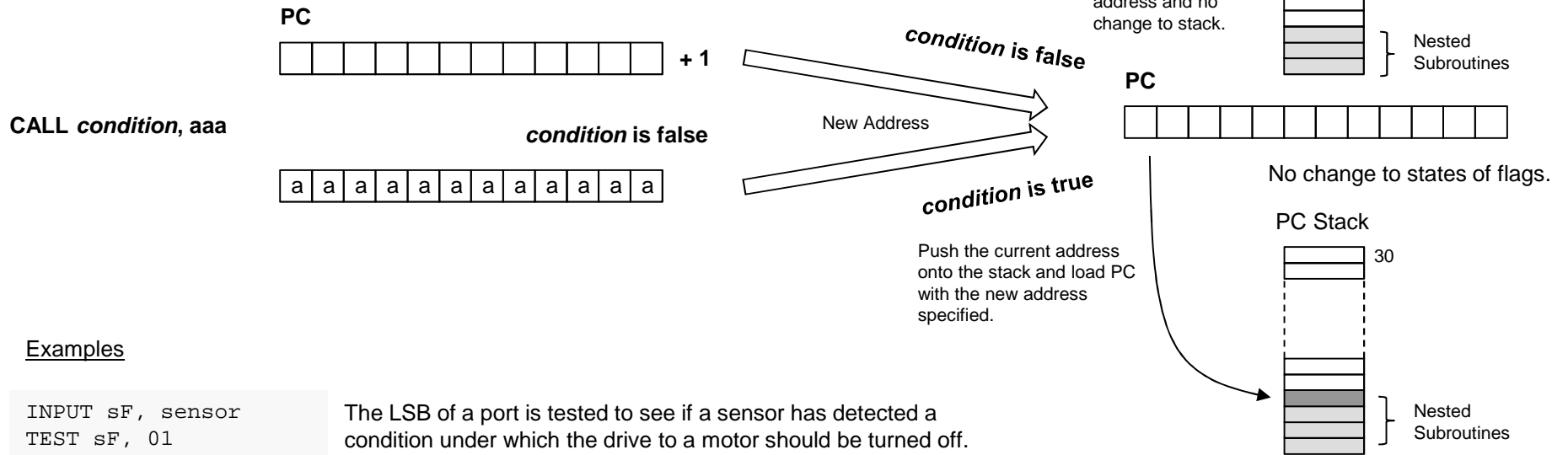

Examples

```
INPUT sF, sensor
TEST sF, 01
CALL NZ, stop_motor
```

The LSB of a port is tested to see if a sensor has detected a condition under which the drive to a motor should be turned off. The 'stop_motor' subroutine is only invoked when the sensor is active.

```
TEST s0, FF
TESTCY s1, 01
CALL C, parity_error
```

An 8-bit value in register 's0' together with a corresponding parity bit located in the LSB of register 's1' are tested. When there are an odd number bits with the value '1' the carry flag is set this is used to detect when there is an even parity error. If that does occur then a special 'parity_error' subroutine is invoked.

CALL@ (sX, sY)

The 'CALL@ (sX, sY)' is an unconditional CALL to a subroutine which pushes the current contents of the program counter (PC) onto the stack and loads the PC with the address defined by the contents of the 'sX' and 'sY' registers.

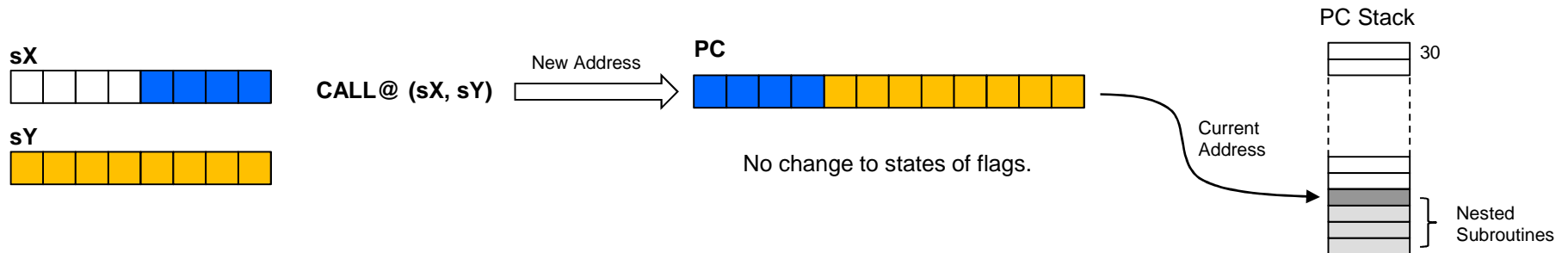

The 12-bit address is formed of the lower 4-bits of the 'sX' register and all 8-bits of the 'sY' register. The upper 4-bits of 'sX' are ignored and the contents of both registers are unaffected by the operation. There is no restriction on which registers can be used but it would be common coding practice to assign an adjacent pair such as 'sB' and 'sA'. As the program counter is loaded, the existing address (the address at which the CALL@ instruction is located) is preserved on the PC Stack to be recovered and used by a RETURN instruction completing the subroutine that has been called.

Whilst the PC Stack is completely dedicated and automatic you are entirely responsible for making sure that for each call made to a subroutine you have a corresponding return. You must also ensure that execution of your program does not exceed 30 'nested' subroutines but this limit is rarely challenged by typical programs. Remember that an interrupt is a special case equivalent to a call and will use one level. If the stack does overflow then KCPSM6 will automatically reset. The real challenge when using the CALL@ instruction is to ensure that the address defined by the pair of registers does correspond with the start of a valid subroutine. Whilst the instruction facilitates a scheme in which the address to call can be computed this also has the potential to be dangerous! The KCPSM6 assembler can do nothing to prevent you computing an inappropriate address but it does provide 'upper and 'lower attributes which are helpful.

Example

Probably the most common use of the CALL@ instruction will be in combination with the LOAD&RETURN instruction to generate text strings or other sequences of constant values and this is explained in more detail in the LOAD&RETURN section.

However, the example shown on the next page illustrates how a system variable is used to decide at which point to enter the same subroutine to achieve a desired set up.

CALL@ (sX, sY)

```

LOAD sB, setup0'upper  → 39C 01B0A LOAD sB, 0A[setup0'upper] ← A49 01047 setup0: LOAD s0, 47["G"]
LOAD sA, setup0'lower  → 39D 01A49 LOAD sA, 49[setup0'lower] ← A4A 01142 LOAD s1, 42["B"]
INPUT s0, currency      02          The KCPSM6 assembler provides 'upper and 'lower
SL0 s0                  04          attributes that can be used with labels to define the 8-
SL0 s0                  08          bit constants to be loaded into the registers.
SL0 s0                  10
ADD sA, s0              49 + 10 = 59
ADDCY sB, 00           0A + 00 + 0 = 0A
CALL@ (sB, sA)

```

CALL A59

In this example we can imagine that KCPSM6 is part of an application involved with foreign currencies and for each different currency it must set up communication using a particular IP Address.

In the main program shown above KCPSM6 reads an input port 'currency' from which it obtains a value in the range 0 to 3 relating to four different currencies but this could be easily expanded to many more. The program then calls the subroutine shown on the right (the LOG file is shown so that the addresses can be seen) which defines the 3-character name of the currency and the IP Address for internet communication in particular scratch pad memory locations.

The CALL@ instruction is used to enter the subroutine at the appropriate address to set up the information that corresponds with the value read into 's0' from the 'currency' port. When the currency is 0 then the address is 'A49' and this was known through use of the 'upper and 'lower attributes which were used to load registers [sB, sA] and required no modification.

For currency values 1, 2 and 3 the target addresses are 'A51', 'A59' and 'A61'. Each target address is 8 instructions apart so the value held in [sB, sA] is modified by the addition of the currency values multiplied by 8 (shift left 3 times). The worked example shown in blue shows how currency value '2' is translated into address 'A59' to enter the subroutine at the European 'setup2'.

```

A49 01047 setup0: LOAD s0, 47["G"]
A4A 01142 LOAD s1, 42["B"]
A4B 01250 LOAD s2, 50["P"]
A4C 016AC LOAD s6, AC[172'd]
A4D 0170E LOAD s7, 0E[14'd]
A4E 0184E LOAD s8, 4E[78'd]
A4F 019BF LOAD s9, BF[191'd]
A50 22A68 JUMP A68[set_mem]
A51 ;
A51 01055 setup1: LOAD s0, 55["U"]
A52 01053 LOAD s0, 53["S"]
A53 01244 LOAD s2, 44["D"]
A54 016C3 LOAD s6, C3[195'd]
A55 0172A LOAD s7, 2A[42'd]
A56 01801 LOAD s8, 01[1'd]
A57 0194A LOAD s9, 4A[74'd]
A58 22A68 JUMP A68[set_mem]
A59 ;
A59 01045 setup2: LOAD s0, 45["E"]
A5A 01055 LOAD s0, 55["U"]
A5B 01252 LOAD s2, 52["R"]
A5C 01695 LOAD s6, 95[149'd]
A5D 017C9 LOAD s7, C9[201'd]
A5E 01805 LOAD s8, 05[5'd]
A5F 01911 LOAD s9, 11[17'd]
A60 22A68 JUMP A68[set_mem]
A61 ;
A61 0104A setup3: LOAD s0, 4A["J"]
A62 01050 LOAD s0, 50["P"]
A63 01259 LOAD s2, 59["Y"]
A64 016C0 LOAD s6, C0[192'd]
A65 017A8 LOAD s7, A8[168'd]
A66 01831 LOAD s8, 31[49'd]
A67 01920 LOAD s9, 20[32'd]
A68 ;
A68 2F010 set_mem: STORE s0, 10
A69 2F111 STORE s1, 11
A6A 2F212 STORE s2, 12
A6B 2F63C STORE s6, 3C
A6C 2F73D STORE s7, 3D
A6D 2F83E STORE s8, 3E
A6E 2F93F STORE s9, 3F
A6F 25000 RETURN

```

8 instructions

8 instructions

8 instructions

RETURN

The 'RETURN' instruction is used to unconditionally complete a subroutine. The last address pushed on to the PC Stack by the previous call to the subroutine is popped off the stack, incremented and loaded into the program counter. This automatic process ensures that the return is made to the address following the CALL instruction that initiated the subroutine.

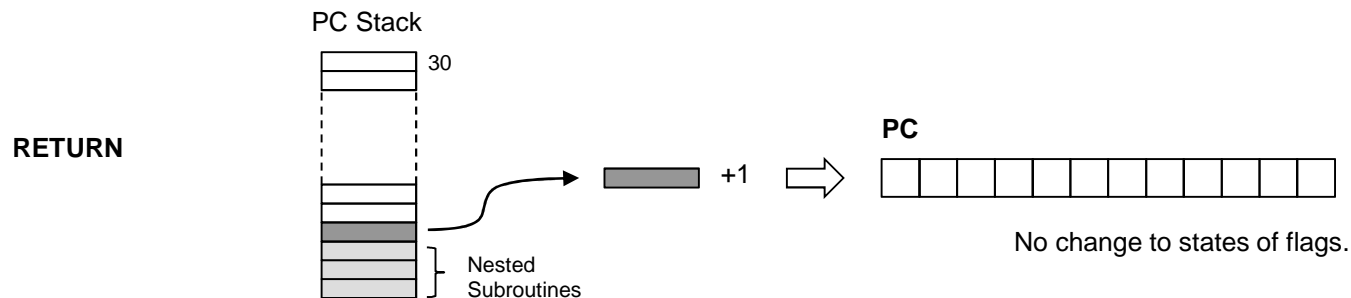

Whilst the PC Stack is completely dedicated and automatic you are entirely responsible for making sure that each RETURN is only executed to complete a subroutine that was invoked by the *corresponding* call instruction. If your code should incorrectly execute a RETURN that results in stack underflow then KCPSM6 will automatically reset. Remember that an interrupt is a special case equivalent to a call and requires a corresponding RETURNI instruction.

Example

```
LOAD s9, 00
LOAD s8, 00
LOAD s1, 30'd
CALL test_stack
OUTPUT s9, 02
OUTPUT s8, 01
```

```
test_stack: ADD s8, s1
            ADDCY s9, 00
            SUB s1, 01
            CALL NZ, test_stack
            RETURN
```

This example illustrates the general arrangement in which one part of the program calls a subroutine. In most cases line labels are used to make the code easier to write and maintain and the assembler resolves the actual addresses.

The subroutine labelled 'test_stack' is called from the main program. When this subroutine completes the RETURN forces the program counter to the address corresponding with the instruction immediately following the CALL which in this case is an OUTPUT instruction.

Whilst this example does show the general arrangement it actually describes a rather special case when we look at the code in detail. In the main program [s9,s8] has been cleared and then 's1' has been loaded with 30 decimal. The 'test_stack' subroutine adds the value of 's1' to [s9,s8] and then decrements the value in 's1'. But each time 's1' is not zero it actually calls 'test_stack' again. Hence this subroutine is called 30 times and eventually [s9,s8] will be the sum of all values from 1 to 30 which is 465 (01D1 hex). When 's1' does reach zero, KCPSM6 will execute the RETURN instruction 30 times until it eventually returns to the main program. Hence there is no restriction on how subroutines are arranged providing you do not exceed 30 levels and every CALL has a corresponding RETURN.

RETURN Z RETURN C

RETURN NZ RETURN NC

These four conditional RETURN instructions will complete a subroutine providing that either the carry flag (C) or the zero flag (Z) is the state specified. If the condition is false the program counter will increment the address and advance to the next instruction. See also description of 'RETURN'.

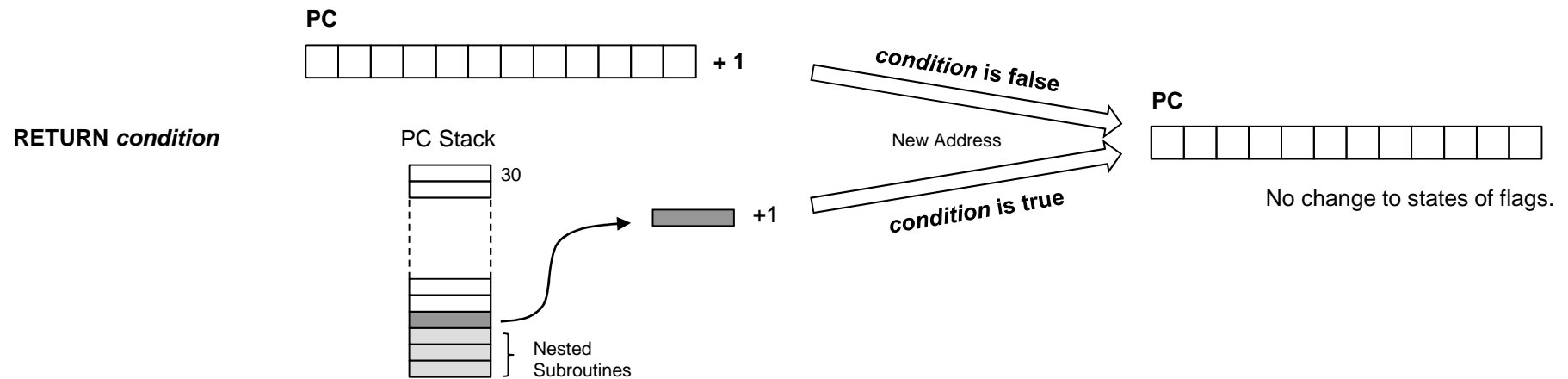

Hint – You are still entirely responsible for making sure that each RETURN is executed to complete a subroutine that was invoked by the *corresponding* call instruction. Because these instructions are conditional you do need to be certain that a corresponding RETURN will be executed at some point so care is required when exploiting these conditional instructions. Many would recommend a coding style in which a subroutine always ends with a single unconditional RETURN instruction and this is certainly a good practice to follow until you have some experience.

Example

```
upper_case: COMPARE s1, 61
            RETURN C
            COMPARE s1, 7B
            RETURN NC
            AND s1, DF
            RETURN
```

This subroutine converts lower case characters to upper case characters. The subroutine examines an ASCII character code provided in register 's1' to determine if it is a lower case letter in the range 'a' (61 hex) to 'z' (7A hex). If the character falls below or above that range then the conditional 'RETURN C' and 'RETURN NC' instructions are used to terminate the subroutine without any modification to the value in 's1'. When the character falls within the lower case range bit5 of the ASCII code is cleared by the 'AND s1, DF' instruction to convert the code into the range 'A' (41 hex) to 'Z' (5A hex) before the unconditional 'RETURN'.

Note that although this subroutine contains three RETURN instructions one is guaranteed to execute especially as the final one is unconditional.

LOAD&RETURN sX, kk

The 'LOAD&RETURN sX, kk' is the combination of a 'LOAD sX, kk' and an unconditional RETURN into a single instruction (i.e. one 18-bit instruction that executes in 2 clock cycles). At the same time that the 'sX' register is being loaded with any 8-bit constant value, the last address pushed on to the PC Stack is by the previous call to the subroutine is popped back off, incremented and loaded into the program counter.

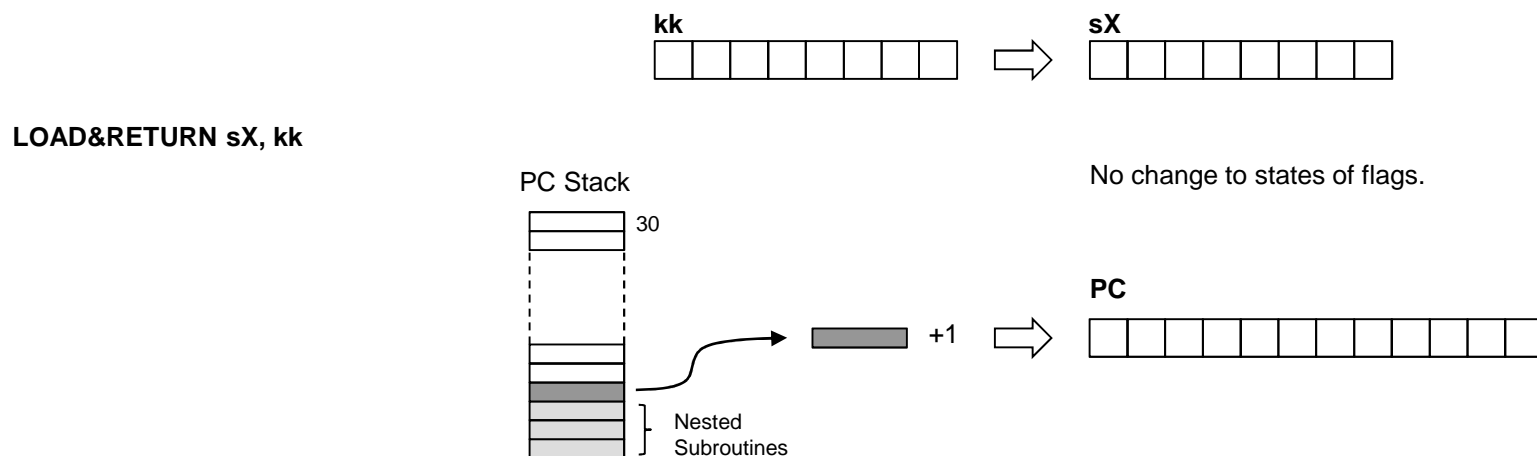

Example

Probably the most common use of the LOAD&RETURN instruction will be in combination with the CALL@ instruction to generate text strings or other sequences of constant values and this is explained in more detail on the next page. However, the LOAD&RETURN instruction can be used to complete any subroutine with the advantage that an 8-bit value can be loaded into any register at no additional cost.

```
print_decimal: COMPARE s5, 10'd
               JUMP C, convert
               LOAD&RETURN sF, 39
convert:      ADD s5, "0"
               CALL print_character
               RETURN
```

This subroutine is used to convert a value in the range '0' to '9' into the equivalent ASCII character before calling a further subroutine that will print it. In addition to the simple conversion the routine checks that the value provided in 's5' is within the range in order that only the expected ASCII characters are printed (and not nasty control characters etc!). This checking means that the outcome of the 'print_decimal' subroutine could be successful or unsuccessful so the LOAD&RETURN instruction is used to load 'sF' with a 'token' or 'error code'. If each subroutine set a different error code into 'sF' then it would be easy for you or the program to locate where things were going wrong in a program especially during code development.

CALL@ (sX, sY)

LOAD&RETURN sX, kk

“Text Strings”

Hint – Also see TABLE Directive on next page

Using 'CALL@ (sX, sY)' and 'LOAD&RETURN sX, kk' instructions together enables a text strings or sequences of constant values to be generated with maximum code efficiency. The KCPSM6 assembler has a STRING directive that simplifies this common application as shown below.

In this example we will assume that text ASCII characters are output from KCPSM6 to a UART transmitter. The UART macro also contains a 16 character FIFO buffer but given that the serial communication is slow compared with KCPSM6 it is necessary for the program to check that the FIFO is not full before sending another character. The 'send_to_UART' routine on the right will wait until the FIFO is not full before outputting the ASCII character provided in 's1'.

```
send_to_UART: INPUT s0, UART_status_port
              TEST s0, tx_full
              JUMP NZ, send_to_UART
              OUTPUT s1, UART_data_port
              RETURN
```

```
send_Help: LOAD s1, "H"
           CALL send_to_UART
           LOAD s1, "e"
           CALL send_to_UART
           LOAD s1, "l"
           CALL send_to_UART
           LOAD s1, "p"
           RETURN
```

To send a string of characters to the UART you can then repeatedly load 's1' with the next character in the sequence and call the 'send_to_UART' subroutine. This was the fundamental technique used in KCPSM3 programs and it still a valid technique to use with KCPSM6. However as users of KCPSM3 have often reported, this tends to consume a significant amount of code space when there are longer and/or many text strings to be generated. It can be seen in this small example that there are 2 instructions associated with each ASCII character and that is quite an overhead. Although the code can be partly optimised for frequently used characters this does not make code easier to write.

The solution with KCPSM6 is to describe each text string using sequential 'LOAD&RETURN' instructions. In this case 's1' loaded with a different character and this is made much easier to write because of the STRING directive. The original PSM code is shown below and the expanded code is shown in the LOG file on the right.

```
STRING Hello$, "Hello World"
Hello: LOAD&RETURN s1, Hello$
       LOAD&RETURN s1, 0D
```

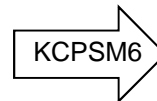

```
3A7          STRING Hello$, "Hello World"
3A7 21148    Hello: LOAD&RETURN s1, 48[Hello$: "H"]
3A8 21165          LOAD&RETURN s1, 65[Hello$: "e"]
3A9 2116C          LOAD&RETURN s1, 6C[Hello$: "l"]
3AA 2116C          LOAD&RETURN s1, 6C[Hello$: "l"]
3AB 2116F          LOAD&RETURN s1, 6F[Hello$: "o"]
3AC 21120          LOAD&RETURN s1, 20[Hello$: " "]
3AD 21157          LOAD&RETURN s1, 57[Hello$: "W"]
3AE 2116F          LOAD&RETURN s1, 6F[Hello$: "o"]
3AF 21172          LOAD&RETURN s1, 72[Hello$: "r"]
3B0 2116C          LOAD&RETURN s1, 6C[Hello$: "l"]
3B1 21164          LOAD&RETURN s1, 64[Hello$: "d"]
3B2 2110D          LOAD&RETURN s1, 0D
```

Each 'LOAD&RETURN' can now be considered to be a single instruction subroutine.

The address of the first 'LOAD&RETURN' instruction is loaded into a pair of registers [sB, sA] and then a routine is called that sends the whole text string to the UART.

```
LOAD sB, Hello'upper
LOAD sA, Hello'lower
CALL send_string
```

```
send_string: CALL@ (sB, sA)
             CALL send_to_UART
             COMPARE s1, 0D
             RETURN Z
             ADD sA, 01
             ADDCY sB, 00
             JUMP send_string
```

The routine requires a suitable scheme in order to terminate. In this case a carriage return is detected.

The 'CALL@' instruction is used to call each 'LOAD&RETURN' subroutine in turn by incrementing the address held in [sB, sA]. Each call returns a character in 's1' which is then sent to the UART. Although this 'send_string' routine is 7 instructions, text strings are now defined by only one instruction per character improving code efficiency by a factor of two.

TABLE Directive for Data and Sequences

Hint – Also see STRING Directive described on previous page.

The TABLE directive is used in conjunction with 'OUTPUTK' and 'LOAD&RETURN' instructions in the same way as a STRING directive except for the fact that it defines a series of constants using numerical values rather than ASCII characters.

```
STRING Hello$, "Hello"    This string is formed of 5 ASCII characters that have the codes 48, 65, 6C, 6C and 6F hex (see previous page).
```

```
TABLE Hex_data#, [48,65,6C,6C,6F]
```

```
TABLE Dec_data#, [72,101,108,108,111]'d
```

```
TABLE Bin_data#, [01001000,01100101,01101100,01101100,01101111]'b
```

These TABLE directives show how the *same* series of 8-bit constants can be defined in hexadecimal, decimal or binary and assigned to a table name ending with # rather than a string name ending with \$. Obviously it doesn't make much sense to replace a string with a table but hopefully these examples emphasize how both directives are used to define a series of constants and you can apply the directive (and radix) that is most suitable for the data you are defining.

Control Sequences using 'OUTPUTK'

On pages 75 and 76 there is a simple example showing how the 'OUTPUTK kk,p' instruction can be efficiently used to generate waveforms for the control of external circuits. The example actually generates a High 'write' enable (bit1) during which a positive clock pulse is generated (bit0).

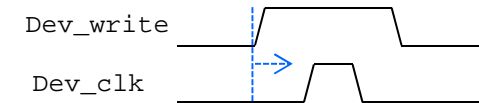

After a TABLE directive has been used to define the series of constants required for each control sequence it enables the code be easier to write. It also makes the code more compact and descriptive which tends to help your code easier to read and maintain.

```
TABLE write_seq#, [00000010,00000011,00000010,00000000]'b
```

```
OUTPUTK write_seq#, Dev_control_port
```

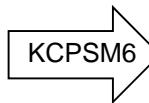

```
OUTPUTK 00000010'b, Dev_control_port
OUTPUTK 00000011'b, Dev_control_port
OUTPUTK 00000010'b, Dev_control_port
OUTPUTK 00000000'b, Dev_control_port
```

Look-Up Tables using 'CALL@' and 'LOAD&RETURN'

On the previous page you can see how this combination of instructions are used to scan sequentially through all the characters forming a text string. Whilst the same requirement could also apply to a table of constants it is more likely that the objective will be to pick out one item from the 'list'. In this example we can see how the value (range 0 to 9) held in the register 's1' can be converted into its equivalent 7-Segment display pattern by selecting the appropriate value from a table....

```
LOAD sB, sevenseg'upper
LOAD sA, sevenseg'lower
ADD sA, s1
ADDCY sB, 00
CALL@ (sB, sA)
```

[sB,sA] loaded with start of table address

Add 's1' to address.

Call to offset address returns required value from table.

```
TABLE 7_segment_decode#, [3F,06,5B,4F,66,6D,7D,07,7F,6F]
sevenseg: LOAD&RETURN s1, 7_segment_decode#
```

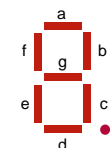

If s1=03 then the 4th value in the table is returned

```
xg fedcba
01001111 = 4F
```

HWBUILD sX

The 'HWBUILD' instruction loads the 'sX' register with the 8-bit value defined by the 'hwbuid' generic set within the hardware design.

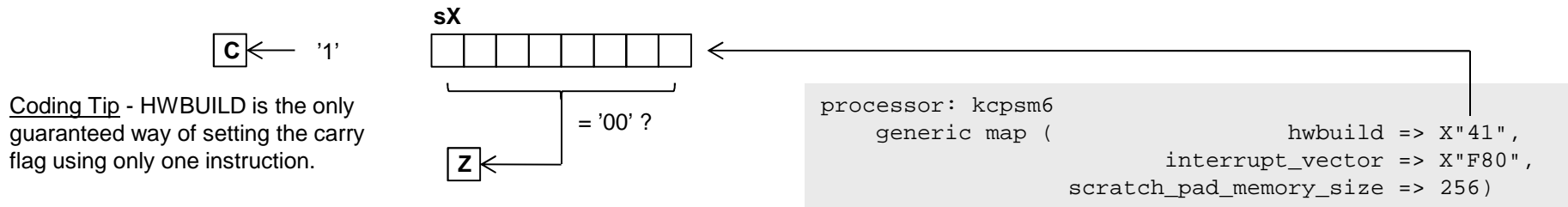

The zero flag (Z) will be set if the value loaded is zero and this corresponds with the default value of the generic on the KCPSM6 macro. The carry flag (C) will always be set (C=1).

Hint – HwBUILD is the only instruction that will always set the carry flag.

You are free to test or use the value loaded into a register by the HwBUILD in any way you wish but here are a few general ways in which you may consider using it in your system.....

Version Control - To enable KCPSM6 to generate a version report (e.g. as part of a message sent to a host or displayed on an LCD). This is the hardware complement to the 'datestamp\$' and 'timestamp\$' for version control of the PSM assembly code.

Hint – The value "41" hex shown above could also be used to represent the ASCII letter for version 'A' or the packed BCD value meaning version 4.1.

Mode Control - Although most of the functionality would probably be the same, a single PSM file could be written that was capable of different behaviour depending on the hardware in which it was being asked to execute within. For example the HwBUILD could be used to:-

- Define if the unit was to act as a master or slave.

- Adjust the command codes and protocol required to access SPI Flash devices from different manufactures.

- Define the feature set supported and/or included in a product.

Priority or Unit Address - When a unit is placed on a bus then it would generally be assigned an address so that it would know when to respond to commands etc. For example, an audio entertainment system may have multiple speakers that fundamentally operate in the same way but each would be assigned to a particular position in the room and therefore be expected to only generate sounds intended for a particular channel.

Hint – If a system only needs to indentify if it is one of two things (e.g. Left or Right, Standard or Advanced etc) then the 'hwbuid' generic could be zero or any non-zero value. When using the 'HWBUILD sX' the zero flag (Z) will be set accordingly ready for an immediate decision to be made in the program.

Notes for KCPSM3 Users

Overall KCPSM6 should look very similar to KCPSM3 because it is ☺. As such, it is expected that the vast majority of KCPSM3 based designs and KCPSM3 programs should work in KCPSM6 with no, or only very minor, adjustments. It is then hoped that you will enjoy learning and including some of the additional instructions and features in your designs at your leisure. The following points should answer your immediate questions and concerns as well as point out the specific items that may just need a little attention depending on your use of KCPSM3.

Hardware Differences

Size and Performance – Even though KCPSM6 has more features than KCPSM3 it has been optimized for Spartan-6, Virtex-6 and 7-Series devices and will appear to be quite a bit smaller (26 Slices) and slightly faster. As such, it really should be a better ISE experience as well.

New Pins – KCPSM6 has 1 additional input pin and 4 additional output pins.....

'sleep' - If you permanently tie the 'sleep' control Low then it will have no effect and KCPSM6 will execute code just like a KCPSM3 (see page 37)

'k_write_strobe' - This output can be left open as it is associated with 16 additional 'constant optimized ports' that have their own 'OUTPUTK' instruction. The normal input and output ports associated with 'read-Strobe' and 'write_strobe' will all behave exactly the same as they did previously. Many PicoBlaze users have expressed their desire for a PicoBlaze that can write constant values directly to a port so KCPSM6 can and you can read more on pages 75 to 80.

'bram_enable' – This is purely a power reduction feature and failure to connect it will have no effect on the execution of a program providing the BRAM containing the program is locally enabled. If you want to continue using your existing 'ROM_form' templates you can but it probably is worth making the small adjustment to include the enable since it is virtually free and will save some power (every little helps!). Given the migration to the '6' and '7' devices it is generally better for you to adopt the new program memory templates which already have the enable input (and 'rdl' output for JTAG Loader). See page 8.

Address[11:10] – So this is the one you probably do need to look at because it means that KCPSM6 can support programs up to 4K. The address port is 12-bits rather than the 10-bit address port of KCPSM3. Of course this means that any KCPSM3 programs will continue to fit in 1K and only the lower 10-bits of the address will really be used in these situations. Whilst address[11:10] are redundant until you implement larger programs, the new program memory templates always connect all 12-bits to make design easy and facilitate easy when required. Please see pages 8 to 13 to see how easy and flexible this is!

New Generics – KCPSM6 has 3 generics (KCPSM3 didn't have any!). The three generics enable you to increase the size of the scratch pad memory, define an interrupt vector address of your choice and define a hardware build value. However, the default settings result in an identical implementation to KCPSM3 meaning that you will have 64 bytes of scratch pad memory and the interrupt vector will be address '3FF'. The hardware build value is associated with a new instruction so will have no effect on code imported from a KCPSM3 design. Put simply, you can ignore the generics until you read page 34.

JTAG Loader – An all new JTAG Loader utility has been provided. The concept is the same but it is easier to include in your design and much easier to use. See pages 25 to 29 for details.

Notes for KCPSM3 Users

Software and Assembler Considerations

KCPSM6 Assembler – Just to state the obvious; you must use the KCPSM6 assembler when targeting KCPSM6 (and you should continue to use the KCPSM3 assembler when targeting KCPSM3 based designs). Whilst the fundamental instruction set is the same the op-codes assigned to the instructions are completely different. The KCPSM6 assembler looks rather different and leaves behind the limitations of the DOS based KCPSM3 assembler but overall its functionality should appear familiar to you. Please see pages 13 and 14 and you will see that it is just as easy to run (see also pages 49 and 50).

'ROM_form' Templates – As with KCPSM3 before, the VHDL and Verilog generated by the KCPSM6 assembler are based on the 'ROM_form.vhd' and 'ROM_form.v' templates which must be placed in the same directory as your PSM file. The key difference is that the KCPSM6 will only generate a VHDL or Verilog file when it finds a corresponding template file. The KCPSM3 assembler used to fail if it did not find all templates and always generated both VHDL and Verilog regardless of which you needed. KCPSM6 will only generate the file type that you need corresponding with the 'ROM_form' template that you provide. If it doesn't generate a VHDL or Verilog file it means that you forgot to provide it with the right template! Please study pages 11 and 12 to learn about the features of the default template including generics that select target family, program size and insert JTAG Loader.

Code Compatibility – KCPSM6 supports the same 30 fundamental instructions that KCPSM3 has and then has 9 new instructions for you to play with in the future. The KCPSM6 assembler also supports the same fundamental syntax for the original instructions as well as the ADDRESS, CONSTANT and NAMEREG directives. As such, all programs written for a KCPSM3 are expected to assemble when porting to KCPSM6. However, you may find that some of the names you have assigned to line labels, constants and registers are rejected by the KCPSM6 assembler and need a small modification. This will occur if the name you have chosen could be confused with a hexadecimal value. For example 'dac' and 'DAC' were acceptable line labels for KCPSM3 but are not accepted by KCPSM6. One reason for this is that KCPSM6 has an address range of '000' to 'FFF' and that means that values such as 'DAC' are now valid hexadecimal addresses. The KCPSM6 assembler has several new features such as the ability to define constants using decimals and ASCII characters (see page 52) but the default is still hexadecimal so you should not need to change anything to begin with.

CALL/RETURN Stack – KCPSM6 supports nesting of subroutines to a depth of 30 levels compared with KCPSM3 which supported 31. However, KCPSM6 will also detect a stack overflow and stack underflow and automatically assert an internal reset. Although this is an enhanced feature for long term design reliability, KCPSM3 code in which stack 'leakage' has previously passed undetected may now reveal its flaw (e.g. where a corresponding RETURN is not performed for every CALL).

ADDCY and SUBCY – All the KCPSM3 instructions are supported in KCPSM6 and execute in exactly the same way except for one very subtle difference in the way ADDCY and SUBCY influence the zero (Z) flag. Both the numerical result loaded into 'sX' and the carry (C) flag behavior are identical so unless your code specifically uses the value of the Z flag following an ADDCY or SUBCY this difference can be ignored. It is actually very rare for the value of the zero flag to be used following an ADDCY or SUBCY in KCPSM3 because it doesn't tend to have a very practical meaning. The subtle change seen in KCPSM6 infers much greater meaning to the zero flag and as a KCPSM3 expert you should soon recognize multiple situations in which your coding becomes easier and smaller. However, because this is the one situation in which code written for KCPSM3 may not execute identically in a KCPSM6 the next page really details the difference as well as acting as an introduction to the new TESTCY and COMPARECY instructions.

Notes for KCPSM3 Users

ADDCY and SUBCY continued..... Consider the simple example in which a 16-bit value is held in the pair of registers [sB, sA] and this is decremented using SUB and SUBCY instructions. This may then be used to define the number of times which a loop is executed. First look at what happens in KCPSM3 in great detail and see how that tends to influence the code that you need to write when using KCPSM3.

```
SUB sA, 01
SUBCY sB, 00
```

in KCPSM3....

Obviously when performing subtraction the carry flag indicates when a 'borrow' is required from the more significant byte.

So first consider when [sB, sA] = 02 00 and the subtraction takes place. The 'SUB sA, 01' results in sA = FF and the carry flag being set. The zero flag is reset because 'FF' is definitely not zero. The 'SUBCY sB, 00' results in sB = 01 as the carry flag has the effect of decrementing sB. The carry flag is now reset because there is no borrow and the zero flag remains reset because '01' definitely isn't zero either. All good so far!

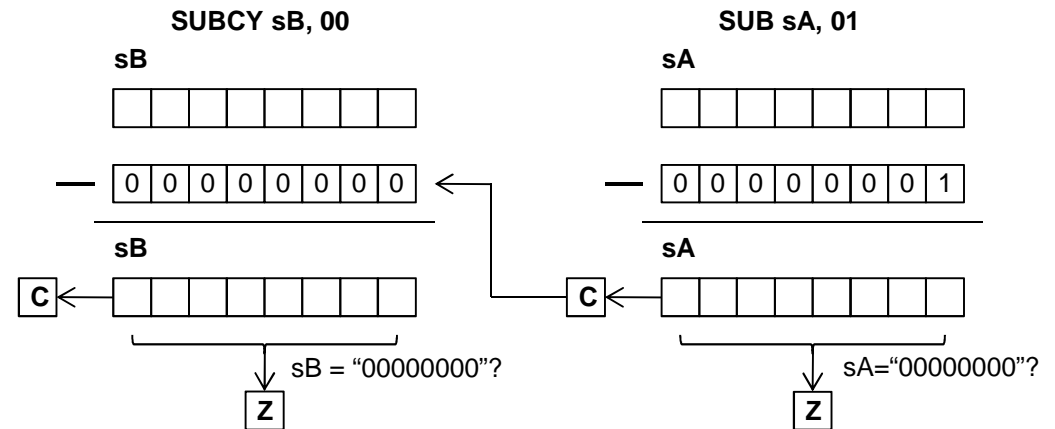

Now imagine that we have decremented 255 more times so that [sB, sA] = 01 00 as we enter the next iteration. Once again 'SUB sA, 01' results in sA = FF and the carry flag being set and the zero flag is reset because 'FF' is still not zero. But this time the set carry flag causes the 'SUBCY sB, 00' to result in sB = 00 which does set the zero flag. Although this correctly reflects the value stored in sB it doesn't reflect the overall result of the 16-bit operation that was actually performed because [sB, sA] = 00 FF and will require another 255 iterations before it truly reaches zero.

```
loop: SUB sA, 01
      JUMP NZ, loop
```

If the decrement loop was performed with an 8-bit value only requiring the 'SUB sA, 01' instruction then the zero flag has the obvious meaning and can provide the test condition for the JUMP instruction as illustrated.

```
loop: SUB sA, 01
      SUBCY sB, 00
      JUMP NZ, loop
```

If the same technique is expanded to 16 bits then the loop will actually terminate when [sB, sA] = 00 FF because the zero flag only represents the result of the local SUBCY instruction. Of course your code could take this into account but it really isn't intuitive or desirable.

```
loop: SUB sA, 01
      SUBCY sB, 00
      JUMP NC, loop
```

Because testing the zero flag terminates the loop 255 iterations too early the typical coding style resorts to testing the condition of the carry flag which is actually set as [sB, sA] rolls over from 00 00 to FF FF (effectively -1). Note how the carry flag is truly representing the result of the whole 16 bit operation in all circumstances.

Notes for KCPSM3 Users

ADDCY and SUBCY continued..... Now look at the same example in KCPSM6 and notice how the subtle change in the way the zero flag is defined. It makes code more logical but may just be a reason to change the way your old KCPSM3 executes in KCPSM6.

```
SUB sA, 01
SUBCY sB, 00
```

in KCPSM6....

The difference is that when the SUBCY executes it observes the state of the zero flag as well as using the carry flag. The zero flag is then only set if the 8-bit result of the SUBCY is zero *and* the zero flag was already set. This means that the zero flag now represents the entire 16-bit result and not just the local 8-bit result.

With this arrangement the flags will have the same meaning having performed a 16-bit operation as they would having performed an 8-bit operation.

Using the same example where [sB, sA] = 01 00 as we enter the decrement function the 'SUB sA, 01' is exactly the same resulting in sA = FF, the carry flag will be set and the zero flag is reset (0) because 'FF' is not zero. The carry flag again causes the 'SUBCY sB, 00' to result in sB = 00 with carry reset but this time the zero flag remains reset because the zero flag was reset before the 'SUBCY' was executed.

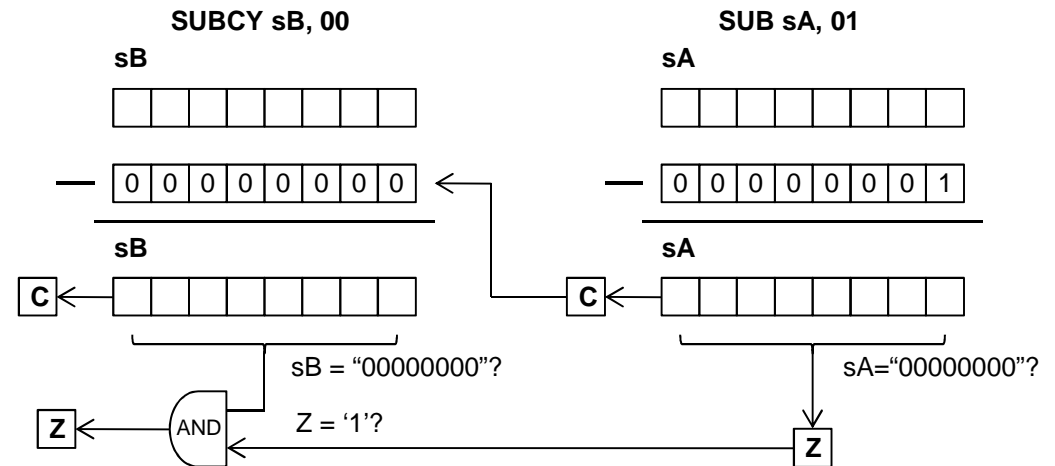

```
loop: SUB sA, 01
      SUBCY sB, 00
      JUMP NZ, loop
```

With KCPSM6 the logical code now works because the zero flag is only set when [sB, sA] = 00 00. This becomes the more obvious coding style for KCPSM6 based programs in the future.

```
loop: SUB sA, 01
      SUBCY sB, 00
      JUMP NC, loop
```

There is a high probability that your KCPSM3 code only uses the carry flag so it will work exactly as it did before. You may also find that for similar reasons your code decomposed the operations into separate 8-bits functions or used COMPARE instructions to test the values of each byte and again this will all work exactly the same.

The advantage of KCPSM6 is that addition and subtraction can now be expanded to any number of bytes and the flags will have the same meaning after the last ADDCY or SUBCY as they would for a simple ADD or SUB. But KCPSM6 goes further by providing you with COMPARECY and TESTCY instructions that have the same ability to expand the COMPARE and TEST instructions. E.g. If you want to compare [sB, sA] with '1234' all you need to do now is 'COMPARE sA, 34' followed by 'COMPARECY sB, 12' and then test the zero flag. Is that nice or what? ☺

KCPSM6 Reliability

Is KCPSM6 Reliable? Quick Answer: Yes!

It would be nice to say that KCPSM6 is 100% reliable and will never ever go wrong. Unfortunately it is all too easy to say and claim such things but the reality is that there is absolutely no product in the world that could truly claim to be absolutely 100% reliable; it simply isn't possible. In practice you have to work on either instinct, or preferably, real data and numbers. The following pages include discussion, numbers and calculations intended to allow you to make your own decisions about how reliable KCPSM6 is and if it is adequate and suitable for inclusion in your designs.

If you are looking for a quick answer and simple guidance then it is fair and reasonable to say that all indications are that KCPSM6 is inherently very reliable and you should have no immediate concerns about using it in your designs. In fact, its level of reliability indicates that virtually all other aspects of using an FPGA device would be of greater cause for concern and that is rarely anything to worry about either ☺.

Seriously, the KCPSM6 is so inherently reliable (providing it is used correctly) that unless you are extremely serious about all aspects of reliability you should stop reading this section now! However, if you are serious (or just interested) then please continue because there is a lot of details and discussions following for you to digest and hopefully enjoy.

Ancestry

KCPSM6 is the 5th in the line of PicoBlaze processors dating back to 1993. Whilst the macro has evolved even the first PSM appears familiar and not so different to KCPSM6 today. With relatively small changes taking place over so many years there is an consistency that helps both KCPSM6 itself to be a good implementation and for users to exploit the high degree of consistency (i.e. Significant changes are an opportunity for systematic errors to creep in).

KCPSM, KCPSM-II and particularly KCPSM3 have been used by thousands of engineers in industry. Combined with their widespread use within educational establishments the potential number of designs is enormous. It should be recognised that the number of combinations in which different instructions could be ordered to form a program (let alone the combinations of data values being processed) is such a large figure that an exhaustive test of every combination would be impossible. As such, every new design and program to this day also serves as a test and validation of each macro.

KCPSM had been actively in use by customers for nearly a year before an interesting combination of events revealed a small but fundamental flaw in the architecture. This was rectified in late 2000 and no other issues have been reported in the (11) years since. In a similar way, it took a year for a KCPSM3 design to reveal an undesirable behaviour. Albeit that this was the result of an essentially improper program this was addressed in 2004 and again there have been no other reported issues in the (7) years following. KCPSM6 benefits from what has been learnt from these rare events of the past.

KCPSM6 is Growing Up

KCPSM6 started to be used by customers in mid-2010. Just over 6 months later an issue was encountered a small but fundamental coding error was discovered in the HDL definition. This was corrected and no other issues relating to KCPSM6 itself have been reported since.

KCPSM6 Reliability

Your Design and Code

The overall reliability of a KCPSM6 based design greatly depends on the quality of your hardware design and program code. Development, testing and debugging are all a natural part of the design engineering process but it is the final state of that design and code when it enters production that defines its operational reliability. Any subsequent failures may be the consequence of inherently incorrect code (hardware or software) but may also reveal that the original design specification was flawed. However, the relative simplicity of KCPSM6 and its ease of use certainly facilitates reliable design as do the following items...

- Standard VHDL or Verilog design flow.
- Fully synchronous design.
- Simple synchronous interfaces.
- Integral local reset circuit automatically used during start-up or to synchronise user input.
- Automatic reset on stack overflow or underflow (i.e. Predictable response even when executing incorrect user code!).
- The coding style of the KCPSM6 source HDL files (i.e. instantiated primitives) minimises synthesis involvement leading to predictable implementation.
- Predictable code execution and timing (e.g. all instructions execute in 2 clock cycles under all conditions).
- Assembler programming has predictable one-for-one correspondence between instructions and memory op-codes.

Whilst a higher level language can be appealing for some applications it also represents the possibility for errors to be introduced by the compiler.

The precise control that assembler code naturally provides is ideally suited to the typical control and monitoring applications that KCPSM6 can service.

Possibly the most challenging aspect of designing for reliability is to anticipate and prepare for the unexpected. For example, imagine that a specification states that data packets begin with the byte value 0A hex followed by 0D hex. The example PSM code shown on the right perfectly meet this specification and therefore work well under normal operating conditions. But now image a situation in which the second byte value has been corrupted before it is received by KCPSM6? Really this possibility should have been a consideration in the original design specification but is the sort of thing that is often overlooked. With the normally good code shown then KCPSM6 will appear to lock-up as it waits indefinitely for 0D hex.

```
packet_start: INPUT s0, data_port
               COMPARE s0, 0A
               JUMP NZ, packet_start
wait_0D: INPUT s0, data_port
          COMPARE s0, 0D
          JUMP NZ, wait_0D
          CALL receive_packet
```

```
LOAD s1, 200'd
wait_0D: SUB s1, 1'd
          JUMP Z, packet_start
          INPUT s0, data_port
          COMPARE s0, 0D
          JUMP NZ, wait_0D
          CALL receive_packet
```

So if a failure occurs, it is important to identify the *root cause* and avoid the temptation to attribute the failure to the KCPSM6 sub-system where the effect was observable (i.e. “don’t shoot the messenger”). In practice, KCPSM6 is well suited to helping you cover for the unexpected situations; unlike a hardware state machine in which each check and exception leads to more states, more logic and therefore increased cost, including more instructions in a KCPSM6 program is (within reason) virtually free. As shown by the refined code on the left, one potential solution to this example is to ‘time-out’ if the second byte is 0A hex isn’t received within a reasonable period (~2,000 clock cycles).

KCPSM6 Reliability

Beyond KCPSM6

KCPSM6 can not exist without an FPGA device to live within or the development tools that enable it to be included within the design. As such the final and total reliability of KCPSM6 depends on everything and not just the macro and your design and code.

The good news is that we have already covered all the items likely to have the greatest impact on the reliable operation of KCPSM6 and are now looking into aspects that should only concern the extreme applications and very highest reliability systems. Please be aware that the analysis becomes ever more involved and detailed and you should already be familiar with failure rate analysis, Failures In Time (FIT) Rates and the 'Device Reliability Report' (UG116) that Xilinx publishes each quarter. However, this may also serve as an introduction to what can be a very interesting subject, but if that is your situation then please do be careful; "a little knowledge can be a dangerous thing" ☺.

Before proceeding it is important to recognise that the purpose of failure analysis is to estimate the operational reliability of a deployed product. Undesirable as it is to encounter issues and deal with them during design development such issues do not impact the long term operational reliability of a final product. The focus must be to identify things about the development tool flow or the physical devices that can result in a deviation from then behaviour defined by the original design and code.

The rather depressing fact is that we learn most when failures actually do occur. Obviously a high number of failures is a bad thing but a low number of observed failures enables real figures to be meaningful and validates that the testing and verification techniques actually do reveal and report any failures. In the earlier 'Ancestry' section it was reassuring to know that there had been no reported issues with KCPSM3 for the last 7 years but made more significant by the fact that it had taken a year and hundreds of users to discover one issue previously. In contrast it is meaningless to claim zero failures when something is never used or only used by very few people to implement the same function every time. FIT rates are the real or estimated number of failures to occur in 10^9 hours (~114,155 years). The larger the number of units/designs/users involved then the greater the accumulation of 'hours' and the more accurate and meaningful (certainty) the FIT figures will carry.

KCPSM6 Assembler – Although not 'beyond KCPSM6' but this tool does need to convert PSM assembler code into the final op-codes executed by KCPSM6 and initialise the program memory with them correctly for correct and reliable operation to be possible. Although there have been incremental improvements to the assembler to aid usability there have been no reported issues relating to incorrect assembly of op-codes or incorrect initialisation using any of the 'ROM_form' templates provided. The one-for-one correspondence between instructions and op-codes really makes this very achievable.

Design Implementation Tools (ISE) – KCPSM6 is ultimately processed as a standard HDL design until it becomes part of configuration image. As such, any errors introduced by the processing tools would not be unique to KCPSM6 but may possibly impact KCPSM6 more readily or at least in an observable way. To date there has only been one issue with the ISE tool flow that has resulted in incorrect behaviour of operation of KCPSM6 when a specific option was changed from the default setting (for details see "global_opt' may result in incorrect implementation' in the 'READ_ME_FIRST.txt' file). Obviously this defect within the ISE tools has been corrected so this specific failure mechanism has been eliminated. With hundreds of users for 2 years it certainly appears that the integrity of the tool flow with regards to KCPSM6 is high.

KCPSM6 Reliability

There are some people for whom soft errors or single event upsets (SEU) generally associated with cosmic radiation are of concern because and FPGA is fundamentally an SRAM based device (albeit that the configuration cells are optimise for the purpose of device configuration rather than 'data memory' so are far more robust or tolerant than typical 'data memory'). In certain applications the concern is a valid consideration and Xilinx takes this subject very seriously both in the design of its products and in the ongoing monitoring and publication of real time soft error rates published each quarter in UG116. Applying this failure analysis information correctly enables sensible decisions to be made. The following analysis relating to a KCPSM6 sub-system in a 7-Series device will estimate the FIT rates associated with SEU. In the end what really matters is how those figures compare with the target figures required for your system (i.e. these real figures must be compared with other real figures and not just with vague claims, or worst of all, human emotions! ☺).

Table 1-17: Real Time Soft Error Rates

Technology Node	Product Family	Neutron Cross-section per Bit ⁽¹⁾			FIT/Mb (Alpha Particle) ⁽²⁾			FIT/Mb ⁽⁵⁾ (Real Time Soft Error Rate) ⁽³⁾		
		Config. Memory	Block	Error	Config. Memory	Block RAM	Error ⁽⁴⁾	Config. Memory	Block RAM	Error ⁽⁴⁾
28 nm	7 series FPGAs	6.99×10^{-15}	6.32×10^{-15}	±10%	34	53	-50% +100%	84	76	-16% +19%

UG116 (v9.5) August 16, 2013

Always use the latest version for the most accurate figures

The 'Real Time Soft Error Rate' are the result of real upsets in real devices and normalised to sea level at New York. These figures are inclusive of all upsets however caused and therefore include the upsets caused by alpha particles (i.e. take care not to account for alpha particles twice when interpreting this table). Note that the potential 'Error' shown in the table from UG116 is -24% to +33%. This appears to be, and is a quite a wide range but is purely a reflection of the low number of actual upsets recorded so far because they truly are rare events! Over time the total number of observed upsets becomes more 'statistically relevant' and the potential error reduces, e.g. the FIT rates for the older Virtex-5 devices now an 'Error' range of just -13% to +15%.

The *nominal* FIT rates shown in the table can be scaled appropriately for the environment in which a device is to be operated. For example the neutron flux density increases with altitude and fluctuates with geographical location. Whilst it is rather pessimistic, scaling the 'Real Time Soft Error Rate' by a factor of 17 would more that cover the use of a device anywhere on the surface of the Earth. This figure over-estimates the increase in neutron flux density and also attributes all of the 'Real Time Soft Error Rate' figures to neutron upsets which clearly isn't the case. Even so, this pessimistic scaling will also be used during the following analysis to ensure the figures presented cover the majority of situations in which a KCPSM6 sub-system would be deployed and facilitate you to make decisions for your system designs.

	Configuration Memory	BRAM contents
Nominal (sea level New York)	84 FIT/Mb	76 FIT/Mb
Pessimistically scaled to the worst location on the surface of the Earth (17x)	1,428 FIT/Mb	1,298 FIT/Mb

1 FIT is equivalent to one failure every 114,155 years.

KCPSM6 Reliability

Estimating FIT Rates of KCPSM6 Program Memory

In most cases a program is stored in a BRAM which is used as a ROM initialised by the KCPSM6 Assembler. The maximum program size is 4K instructions but a typical program today consists of less than 1K instructions. However, with the native size of a BRAM in the 7-Series being 36-kbits there is a tendency to specify a program memory size of 2K instructions and for program sizes to be gradually increasing as KCPSM6 starts to be exploited more.

Obviously the larger the memory (more bits) then the higher the probability of a single event upset (SEU) occurring. Using the 'Soft Error Rates' it is possible to estimate the FIT rate for a PicoBlaze program memory as a whole. In practice, KCPSM6 must actually fetch and execute an instruction containing an upset in order for it to have any potential of deviating from its normally expected behaviour. Clearly any memory locations not occupied by instructions will not be executed and therefore an upset occurring in unused locations should never affect the program execution. For this reason the estimated FIT rate for operational failure should at least be scaled to the actual size of a program rather than the total memory capacity (hint – see the assembler LOG file).

Somewhat less obvious and rather more effort to establish is how many instructions of a program are actually critical for normal operation. It is normal for a program to include code that is only executed during initialisation so any of those instructions (memory locations) could incur an upset during normal operation with no adverse effect on the operation. For those extremely serious about reliability then a program should be analysed in more detail looking at which instructions are really critical to operation. It is even possible to analyse individual instructions for their critical parts. For example, the bits of an op-code defining the instruction would be considered critical but an 8-bit constant defining an ASCII character in a text message is less so.

The table below estimates nominal and pessimistically scaled FIT rates for different sizes of program memory and includes the estimate for 0.5K instructions of critical code (0.5K is probably a large amount of critical code even if a complete program occupied most of a 2K memory). It is important to remember that these FIT rates (and their corresponding time intervals) represent the *potential* for a KCPSM6 execution error to occur due to a bit change somewhere in an instruction. For KCPSM6 to deviate from the expected behaviour it must execute the corrupted instruction *and* the result of that execution must be different to that required. For example, 'COMPARE s4, 23' is not the same as 'COMPARE s4, 27' but unless this change results in the incorrect setting of the zero or carry flag that is subsequently used in the program then no failure will have occurred at that time. Hence the figures below should be interpreted as being very pessimistic but they are still very small; how do they compare with the FIT rate requirements of your system?

	2K Instruction Memory (0.036864Mb)	1K Instruction Memory (0.018432Mb)	0.5K Critical Configuration Instructions (0.009216Mb)
Nominal 76 FIT/Mb (sea level New York)	2.80 FIT (40,745 years)	1.40 FIT (81,491 years)	0.70 FIT (162,982 years)
Pessimistically scaled to the worst location on the surface of the Earth (17x)	47.62 FIT (2,397 years)	23.81 FIT (4,794 years)	11.91 FIT (9,587 years)

KCPSM6 Reliability

Estimating FIT Rates of KCPSM6 Logic and Interconnect

The KCPSM6 processor occupies 26 to 28 Slices depending on the size of scratch pad memory specified. To be of practical use, KCPSM6 would typically be associated with logic providing several input and output ports and possibly some additional logic to service interrupts. It is left to personal debate to decide what logic in a design constitutes the KCPSM6 sub-system but a figure of 40 Slices appears to be reasonable for the purposes of estimation. This would include the immediate interfacing logic but application specific peripherals are considered to be modules in their own right with their own reliability figures.

In order to be able to estimate the FIT rates of these 40 Slices it is first necessary to have an estimate for the number of configuration memory cells associated with each Slice. It is important to remember that it is not just the configuration cells that define the logic within each Slice but also the configuration cells that define a fair share of the interconnect associated with each Slice. Whilst the contents of the BRAM have been accounted for separately (i.e. Program Memory) it is also necessary to account for the configuration cells which define the format of the BRAM and its associated interconnect.

The following table from PG036 provides the estimates of configuration bits.

LogiCORE IP Soft Error Mitigation Controller v3.2

Product Guide

PG036 April 24, 2012

Table 2-6: Configuration Bits Per Device Feature

Device	Device Feature (Includes Routing)	Approximate Number of Configuration Bits
7 Series FPGAs	Logic Slice	1,166
	Block RAM (36Kb)	9,396
	Block RAM (18Kb)	4,698
	I/O Block	2,850

The 7-Series devices have a built-in Readback CRC mechanism that can be enabled to continuously scan all the static configuration cells in order to detect and report any upsets to bits caused by single even upsets (SEU). Typical device scan times are in the 10ms to 100ms range depending on device size and therefore this it also the typical time taken to detect and report an upset should it occur. In addition, it is possible to automatically correct errors once detected. Any upset will be detected and reported. However, only a small percentage of upsets will have any effect on the operation of the design. Unsurprisingly, no design will ever use all the possible resources provided in a device and in fact the majority of configuration cells will be associated with flip-flops, LUT's, carry logic, interconnect etc that are completely unused by a particular design. Hence, upsets to any of those configuration cells will have no affect on the operation of the design. Rather less obvious is that even when logic and interconnect is part of a design, then not all logic and paths are actively being used all of the time, and as a result, there will often be no observable effects to the operation of a design even if a configuration cell is changed by an SEU. The combined effect of these factors is that it is rare for any part of a design to be sensitive to 10% of upsets with most circuits in the 1% to 5% susceptibility range.

KCPSM6 Reliability

The table below estimates nominal and pessimistically scaled FIT rates for a KCPSM6 sub-system comprising of 40 Slices, a 1K instruction BRAM and associated interconnect. The rate at which configuration memory cells are upset is shown in the left hand column and is the rate that the device level Readback CRC mechanism would be expected to detect and report upset. The right hand column assumes that only 8% of upsets will functionally impact operation of KCPSM6. This figure was actually observed when using error injection facility of the SEM IP core to simulate thousands of SEU in a Kintex-7 design containing 400 KCPSM6 instances.

KCPSM6 Sub-System (40 Slices + 1K BRAM= 0.051338Mb)	Device SEU Detection Rate (84FIT/Mb)	KCPSM6 Operational Failure Rate (8%)	Note: The 'Device SEU Detection Rate' figures are the rate proportional to the size of the KCPSM6 sub-system. In reality the detection is device centric. For example, the nominal detection rate for an XC7K480T device would be in the region of 8,000 FIT (14 years) of which 0.05% of the error reports could be expected to relate to a KCPSM6 sub-system. In this game it really helps to be small and KCPSM6 is ☺.
Nominal 84 FIT/Mb (sea level New York)	4.31 FIT (26,471 years)	0.34 FIT (330,892 years)	
Pessimistically scaled to the worst location on the surface of the Earth (17x)	73.31 FIT (1,557 years)	5.86 FIT (19,464 years)	

The Complete KCPSM6 Solution (Program Memory and Logic)

Combining the estimated FIT rates for both the program memory and the logic resources of a typical KCPSM6 sub-system reveals the total estimated FIT rates. It is also useful to observe the relative effects an SEU is likely to have on the program memory and the logic. In order to avoid 'number overload' the figures presented below have been limited to a program memory of 1K instructions of which 0.5K are considered to be critical to operation. This covers most typical configurations but obviously you should collate the figures appropriate to your design (no forgetting to apply FIT rates from the latest version of UG116).

1K Instruction Memory (with 0.5K critical Instructions) 40-Slice KCPSM6 Sub-System (with 8% susceptibility)	Total upset Rate	Operational Failure Rate
Nominal (sea level New York)	1.40 FIT (BRAM) 4.31 FIT (Logic) 5.71 FIT (Total)	0.70 FIT (BRAM) 0.34 FIT (Logic) 1.04 FIT (Total)
Pessimistically scaled to the worst location on the surface of the Earth (17x)	23.81 FIT (BRAM) 73.31 FIT (Logic) 97.12 FIT (Total)	11.91 FIT (BRAM) 5.86 FIT (Logic) 17.77 FIT (Total)

KCPSM6 Reliability

Interpreting the KCPSM6 Sub-System FIT Rates

Design for reliability should be driven by the *operational* FIT rates and so the first and most significant observation is that these (pessimistic) estimates are very low indeed; 1.04 FIT under nominal conditions and still less than 18 FIT when pessimistically scaled. To put these figures into context the following abstracts from UG116 reveal the fundamental hardware failure rate of the device.

Table 1-16: Summary of the Failure Rates

Process Technology	Device Hours at $T_J = 125^\circ\text{C}$	FIT ⁽¹⁾
0.028 μm	495,908	24

Table 2-1: Summary of HTOL Test Results (Cont'd)

Device	Lot Quantity	Fail Quantity	Device Quantity	Actual Device Hours at $T_J \geq 125^\circ\text{C}$	Equivalent Device Hours at $T_J = 125^\circ\text{C}$	Failure Rate at 60% CL and $T_J = 55^\circ\text{C}$ (FIT)
7 Series FPGAs	3	0	231	385,000	495,908	24

Total hardware failure rates would also need to include the FIT rates associated with the board on which the device is mounted and various power supplies that enable it to operate in the first place.

Quite simply, the main conclusion to be made is that unless the device containing KCPSM6 is to be operated in a significantly more hostile environment than the potential for KCPSM6 to fail during operation is negligible compared with just about everything else including the very hardware that surrounds it. Of course total system reliability is the sum of many small parts and everything does contribute so it would be inappropriate to suggest that the FIT rate of KCPSM6 should be completely ignored. However, it would be equally inappropriate for concern about such a low FIT rate to result in additional time and effort being expended in order to address the impact of SEU on KCPSM6 reliability until other parts of a system with much higher FIT rates have been adequately addressed. Interestingly the extremely low FIT rate of KCPSM6 actually makes it a suitable candidate for the monitoring and management of other functions with higher FIT rates and indeed this is one of the application areas in which KCPSM6 is used in large FPGA devices.

In reality, the actual operational reliability of KCPSM6 operational almost certainly depends more on the quality of the hardware design and PSM code so this is almost certainly the area where most time and effort should be invested as it will yield the greatest improvement in KCPSM6 operational reliability. Remember that 'real numbers' should really be compared with other 'real numbers' rather than 'words and emotions'. Since it would be virtually impossible to prove that the hardware design and PSM program also achieved a nominal FIT anywhere near as low as 1.04 FIT, it is a definitive indication that the design and code is the area to focus on.

Error Detection for Very High Reliability Designs

The fact is that nothing can be absolutely 100% reliable, so albeit undesirable, it is acceptable for failures to occur up to a defined FIT rate. For the majority of electronic products, the point of failure is simply seen as the time to try “turning it off and back on again” or when that doesn’t work, to go to and buy a new model! Providing the failure rate is low enough to prevent your products gaining a bad reputation then such failures actually become an opportunity to sell a new product (like it or not, that’s consumerism!). However, in some applications there is a far more exacting requirement in which it is not so much the actual failure rate that matters, but how failures will be handled when they do occur.

Consideration is given to the characteristics of potential failures and the course of action to be taken in response to each. Such analysis will often lead to a strong desire to detect when a failure or error has occurred. In fact, when it comes to very high reliability equipment the requirement for error detection and reporting will be part of the product specification from the outset and demanding a confidence level that far exceeds the acceptable failure rate of a unit’s main functionality. The general premise being that it whilst it is undesirable for a system to suffer a failure, it is almost totally unacceptable for any failure to pass unnoticed and for the equipment to continue operating erroneously for an indefinite period. In this area there is no such thing as a standard solution; every system will have its own requirements and priorities as the following contrasting examples hopefully illustrate.

- 1) A data back-up system has “five nines” availability (i.e. 99.999% availability equates to ~5 minutes of downtime per year) and is required to maintain a good copy of information. It is vital that any failures or errors are detected in order to prevent the back-up data from being corrupted. When an error is reported the system will keep operating in order to meet the availability target. However, the error report will trigger additional checks will be performed to establish the cause of the error, and when possible, make a running repair. The integrity of the data will be achieved though a repeat of any tasks previously performed during the period prior to the error being detected through to the time when the repair had been completed.
- 2) A high reliability communication link employs a Triple Modular Redundancy (TMR) scheme. Through this arrangement it is possible for the system as a whole to continue operating normally when one unit fails. If one unit provides conflicting information the voting mechanism will ignore that unit in favour of the other two. In this case the voting mechanism could also be the error detector but if each unit can detect and report errors independently before the voting mechanism even observes anything wrong then the sooner a failed unit can be taken off line, ‘repaired’ and returned to operation. This minimises the time the system is reliant on two out of three units and also means that voter mechanism is a secondary monitor (i.e. Detection redundancy).
- 3) A gas valve controller has no electronic redundancy and the acceptable operational failure rate is surprisingly high. However, it is vital that the gas valve should always shut off should any error occur. The valve is fitted with a mechanical bias to close during a power failure so the requirement is that the controller stops driving the value open as soon as any potential error is reported. A service engineer will be called to implement any repairs and will be present to manually put the controller back on line and verify that it is operating correctly.

In each of these applications it is highly desirable for the detection and reporting to occur rapidly; the longer it takes to detect an error the longer things could be going wrong in the system. But the overwhelming requirement is that no failures or errors should be missed completely.

Error Detection for Very High Reliability Designs

Unfortunately, it must again be recognised that an error detection and reporting mechanism can not be 100% reliable either. This means that there will always be a finite limit to what can be achieved and if that fault detection is inadequate within a given unit then different parts of a system must be used to 'cross-check' each other (i.e. employing redundancy in error detection too).

With respect to the vital requirement that no genuine failures or defects should pass undetected and unreported then, in most cases, the level of error detection and reporting will be considered to be acceptable. However, the price to be paid for having an extremely high coverage of the genuine errors is that there will also be 'false alarms' or, more significantly, what appear to be 'false alarms'. Although every system will have its own specific requirements the following FIT rates could be representative of the targets for a system. In particular, these example figures illustrate realistic rates relative to each other...

Operational Failure Rate:	11,400 FIT	(MTBF = 10 years)
Unreported Operational Failure Rate:	23 FIT	(MTBF = 4963 years)
Error Detection and Reporting Rate:	114,000 FIT	(MTBF = 1 year)

These example figures indicate that it is extremely unlikely (23 FIT) that a genuine error will occur without it being reported. However, an 'alarm' (i.e. an error detection report) is expected once per year (114,000 FIT) even though an operational failure is only expected once every 10 years (11,400 FIT). This implies that 9 out of 10 alarms will appear to be 'false alarms'. Hence it is necessary to consider the potential causes of alarms to avoid making the all too common human mistake of ignoring them all the time!

Genuine alarm - This is the straightforward case in which the alarm is accompanied immediately by obvious erroneous behaviour of the unit. Based on the above figures this the 1 in 10 that was expected and planned for all along. It is primary reason for error detection and reporting to achieve the target (23 FIT).

Failure of alarm circuit - The error detection and reporting circuit can not itself be 100% reliable so there will be occasions in which a failure of that detection circuit will result in an error report (alarm) when the unit is functioning correctly. In fact, it is the genuine detection and reporting of an error but just not in the functionality that you really care about but there is no way to separate them unless you have redundancy in detection. If KCPSM6 was used to monitor circuits to detect and report errors then its nominal 1.06 operational FIT is an indication of how unlikely it is for a detection circuit to be the cause of false alarms. Low FIT rates must be understood and believed especially when it appears that everything else is working normally.

Apparent false alarm - The alarm occurs but no abnormal behaviour in the system is observed. Based on the example figures above this will account for almost all of the 9 out of 10 apparently 'false alarms'. The 'alarm' is the result of the error detection mechanism truly finding and reporting a genuine error somewhere in the unit and this actually makes each of these alarms a genuine alarm. The issue is that unless the failure is widespread or in a critical spot it is very common for nothing abnormal to be observed. For example, if you were to secretly unplug a telephone from the wall socket how long would it take its owner to think "it's been a long while since my phone rang" and subsequently lift the receiver to discover that the line is dead. In a similar way (and as described in the previous pages), a corruption to a KCPSM6 instruction in the program memory is a genuine error but only observable if and when KCPSM6 executes that particular instruction and the outcome of that execution is a deviation from the normally intended behaviour.

Error Detection for Very High Reliability Designs

[Hint](#) – Also read about the 'DEFAULT_JUMP' directive in 'all_kcpsm6_syntax.psm'.

Detecting Errors in KCPSM6 Logic

The 7-Series devices have a built in Readback-CRC mechanism (see 'Readback CRC' chapter in UG470 for more details) that will detect and report any changes to the otherwise fixed configuration cells anywhere in the device (e.g. the result of a single event upset). Using this mechanism will therefore detect and report any upsets associated with the logic and interconnect of a KCPSM6 processor although of course this would only represent a small fraction of the total errors detected of the whole device.

The 7-Series devices also provide the ability to correct configuration errors but due consideration should be given to the fact that it will typically take tens of milliseconds for an error to be detected and corrected and there is a small but definitive probability for erroneous operation of a KCPSM6 processor (or any other logic) during that period of time. High reliability systems must employ appropriate techniques but where KCPSM6 plays a critical part in a design then the most common course of action is simply to reset (restart) KCPSM6 following any error detection and its subsequent correction just in case it was associated with the processor and possibly impacted its behaviour.

Detecting Errors in KCPSM6 Program Memory

Whilst the contents of BRAM form part of the initial configuration image they are not scanned by the built in Readback-CRC mechanism because in most applications the BRAM will contain variable data. Therefore, in the unlikely situation (2.80 nominal FIT for 2K instructions) that a single event upset flips a bit within a BRAM used to hold a PicoBlaze program this would present the potential for KCPSM6 to execute a corrupted instruction without that error being detected or reported. Clearly for some systems undetected errors are highly undesirable and even 2.80 FIT starts to become significant (especially when a design employs multiple KCPSM6 processors). Therefore, for these special cases a method for error detection within the program is also required.

Implementing Program Memory in Slices (Distributed ROM)

Each Slice contains 4 LUTs that can be combined to implement a 256-bit ROM. Multiple Slices can be used to form larger memories as shown in the table below. With the LUTs being used as ROM the program memory becomes part of the otherwise static configuration cells so the device level Readback CRC mechanism will include error detection coverage of the KCPSM6 program memory as well as the processor itself (and all other logic and interconnect in the design). The detection FIT rate and estimated operational failure rate related to the Slices used to implement each program memory is also shown below.

Program Size	Slices	Total Upset Rate (84FIT/Mb)	Operational Failure Rate (10%)
128 Instructions	9	0.94 FIT	0.09 FIT
256 Instructions	18	1.89 FIT	0.19 FIT
512 Instructions	39	3.77 FIT	0.38 FIT
1024 Instructions	77	7.54 FIT	0.75 FIT

IMPORTANT - When a BRAM provides 1K instructions the total error rate is 1.40 FIT. Hence the migration to Slices to achieve error detection is only compelling for small programs..

Hint - Templates are provided for the 128 and 256 instruction memories implemented using Slices.

Error Detection for Very High Reliability Designs

Hint – Also read about the 'DEFAULT_JUMP' directive in 'all_kcpsm6_syntax.psm'.

Error Detection for BRAM Program Memory

The suitability of BRAM for a KCPSM6 program combined with its low FIT rate makes it appealing in all ways except for the lack of error detection. Actually the BRAM's do provide the option for 'ECC' (see 'Built-in Error Correction' chapter of UG473) which could be employed to detect and correct errors and worthy of consideration. However, it does require BRAM to be configured in a 512x72 aspect ratio (64-bit user data) which does not fit well with KCPSM6 programs typically consisting of more than 512 instructions all of which are 18-bits.

The recommended solution is provided by the 'ROM_form_7S_2K_with_error_detection_14March13.vhd' template which provides a 2K instruction program memory with a completely independent CRC scanning circuit for error detection. Each scan takes 36,873 'scan_clk' cycles which yields detection times of less than 1ms. The 'scan_error' signal could be OR'ed with the device level Readback CRC error status or the localised nature of the detection exploited.

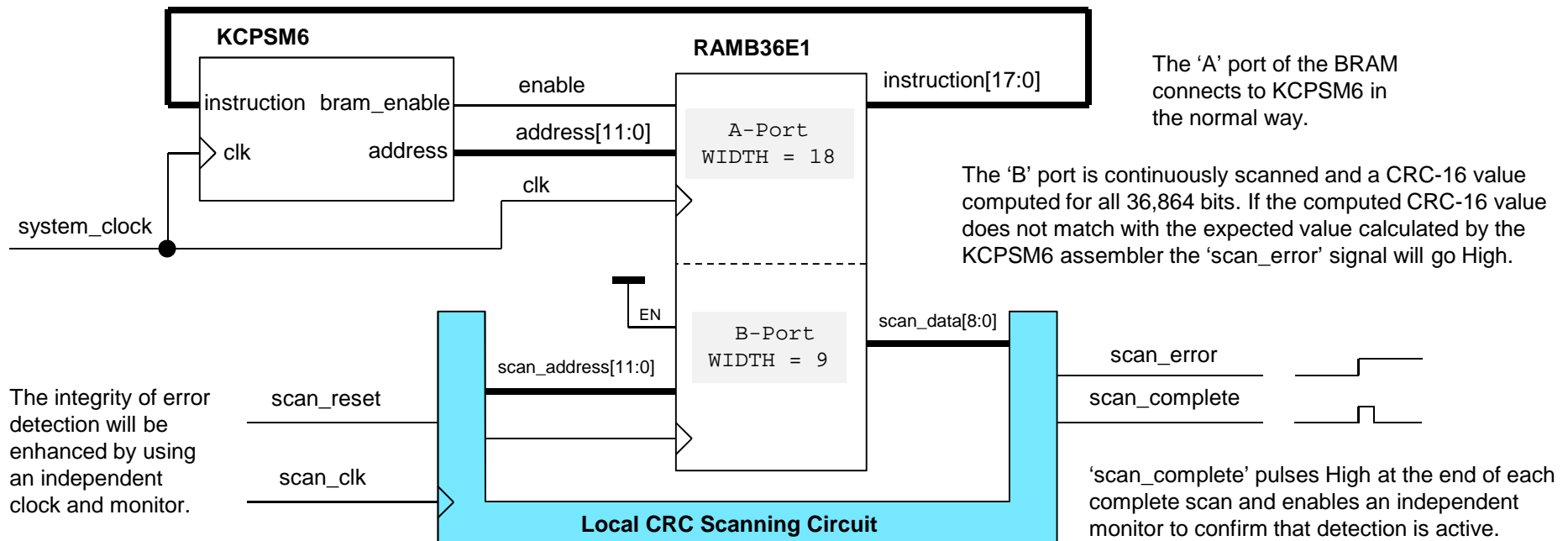

Hint – Additional descriptions contained in the 'ROM_form_7S_2K_with_error_detection_14March13.vhd' template should be studied.

Note – At this time a template is only provided for a 2K program memory in VHDL. Please contact the author if you require a 1K or 4K template or verilog.

Error Detection for Very High Reliability Designs

The localised CRC scanning error detection does not provide error correction but it should be remembered that the nominal FIT rate of a 2K instruction BRAM is only 2.80 FIT and the operational FIT is always expected to be less. In a fail safe environment any detected error is taken seriously and if this results in a shut down and subsequent reconfiguration of the device then this will correct the soft error in the BRAM just as it would correct a soft error in the configuration cells of the device.

If a high reliability system must continue operating (at least for some time) then some degree of redundancy must be employed. This could imply TMR techniques but in this situation where the error detection is localised to the program memory contents it is reasonable to implement a master/slave arrangement as shown below.

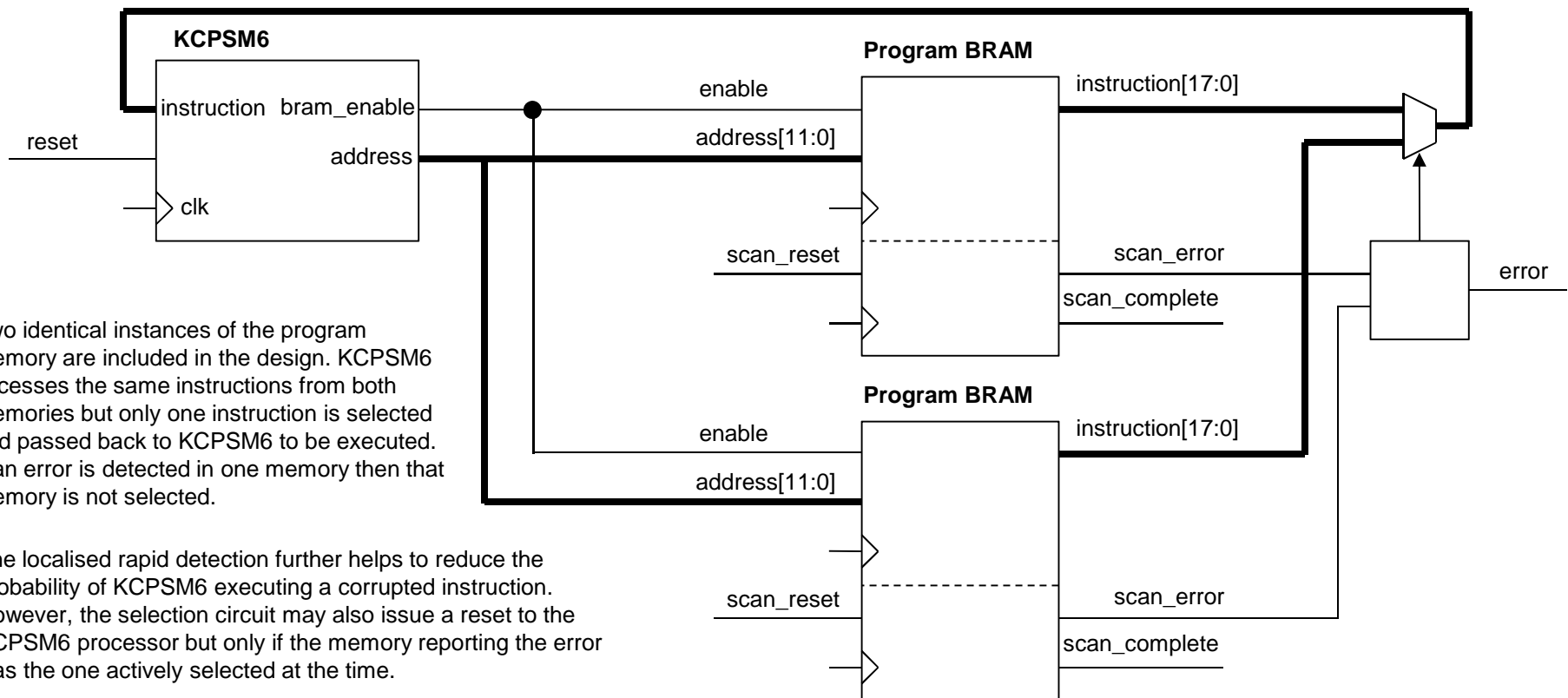

Two identical instances of the program memory are included in the design. KCPSM6 accesses the same instructions from both memories but only one instruction is selected and passed back to KCPSM6 to be executed. If an error is detected in one memory then that memory is not selected.

The localised rapid detection further helps to reduce the probability of KCPSM6 executing a corrupted instruction. However, the selection circuit may also issue a reset to the KCPSM6 processor but only if the memory reporting the error was the one actively selected at the time.