

CSCI 104

Iterators

Mark Redekopp

David Kempe

C++11, 14, 17

- Most of what we have taught you in this class are language features that were part of C++ since the C++98 standard
- New, helpful features have been added in C++11, 14, and now 17 standards
 - Beware: compilers are often a bit slow to implement the standards so check the documentation and compiler version
 - You often must turn on special compile flags to tell the compiler to look for C++11 features, etc.
 - For g++ you would need to add: **-std=c++11** or **-std=c++0x**
- Many of the features in the next C++11 are part of a 3rd party library called Boost

Plugging the leaks

SMART POINTERS

Pointers or Objects? Both!

- In C++, the dereference operator (*) should appear before...
 - A pointer to an object
 - An actual object
- "Good" answer is
 - A Pointer to an object
- "Technically correct" answer...
 - EITHER!!!!
- Due to operator overloading we can make an object behave as a pointer
 - Overload operator *, &, ->, ++, etc.

```
class Thing
{
};

int main()
{
    Thing t1;
    Thing *ptr = &t1

    // Which is legal?
    *t1;
    *ptr;
}
```

A "Dumb" Pointer Class

- We can make a class operate like a pointer
- Use template parameter as the type of data the pointer will point to
- Keep an actual pointer as private data
- Overload operators
- This particular class doesn't really do anything useful
 - It just does what a normal pointer would do

```
template <typename T>
class dumb_ptr
{ private:
    T* p_;
public:
    dumb_ptr(T* p) : p_(p) { }
    T& operator*() { return *p_; }
    T* operator->() { return p_; }
    dumb_ptr& operator++() // pre-inc
        { ++p_; return *this; }
};

int main()
{
    int data[10];
    dumb_ptr<int> ptr(data);

    for(int i=0; i < 10; i++){
        cout << *ptr; ++ptr;
    }
}
```

A "Useful" Pointer Class

- I can add automatic memory deallocation so that when my local "unique_ptr" goes out of scope, it will automatically delete what it is pointing at

```
template <typename T>
class unique_ptr
{ private:
    T* p_;
public:
    unique_ptr(T* p) : p_(p) { }
    ~unique_ptr() { delete p_; }
    T& operator*() { return *p_; }
    T* operator->() { return p_; }
    unique_ptr& operator++() // pre-inc
        { ++p_; return *this; }
};

int main()
{
    unique_ptr<Obj> ptr(new Obj);
    // ...
    ptr->all_words()
    // Do I need to delete Obj?
}
```

A "Useful" Pointer Class

- What happens when I make a copy?
- Can we make it impossible for anyone to make a copy of an object?
 - Remember C++ provides a default "shallow" copy constructor and assignment operator

```
template <typename T>
class unique_ptr
{ private:
    T* p_;
public:
    unique_ptr(T* p) : p_(p) { }
    ~unique_ptr() { delete p_; }
    T& operator*() { return *p_; }
    T* operator->() { return p_; }
    unique_ptr& operator++() // pre-inc
        { ++p_; return *this; }
};

int main()
{
    unique_ptr<Obj> ptr(new Obj);
    unique_ptr<Obj> ptr2 = ptr;
    // ...
    ptr2->all_words();
    // Does anything bad happen here?
}
```

Hiding Functions

- Can we make it impossible for anyone to make a copy of an object?
 - Remember C++ provides a default "shallow" copy constructor and assignment operator
- Yes!!
 - Put the copy constructor and operator= declaration in the private section...now the implementations that the compiler provides will be private (not accessible)
- You can use this technique to hide "default constructors" or other functions

```
template <typename T>
class unique_ptr
{ private:
    T* p_;
public:
    unique_ptr(T* p) : p_(p) { }
    ~unique_ptr() { delete p_; }
    T& operator*() { return *p_; }
    T* operator->() { return p_; }
    unique_ptr& operator++() // pre-inc
        { ++p_; return *this; }
private:
    unique_ptr(const UsefultPtr& n);
    unique_ptr& operator=(const
                          UsefultPtr& n);
};

int main()
{
    unique_ptr<Obj> ptr(new Obj);
    unique_ptr<Obj> ptr2 = ptr;
    // Try to compile this?
}
```

A "shared" Pointer Class

- Could we write a pointer class where we can make copies that somehow "know" to only delete the underlying object when the last copy of the smart pointer dies?
- Basic idea
 - shared_ptr class will keep a count of how many copies are alive
 - shared_ptr destructor simply decrements this count
 - If count is 0, delete the object

```
template <typename T>
class shared_ptr
{ public:
    shared_ptr(T* p);
    ~shared_ptr();
    T& operator*();
    shared_ptr& operator++();
}

shared_ptr<Obj> f1()
{
    shared_ptr<Obj> ptr(new Obj);
    cout << "In F1\n" << *ptr << endl;
    return ptr;
}

int main()
{
    shared_ptr<Obj> p2 = f1();
    cout << "Back in main\n" << *p2;
    cout << endl;
    return 0;
}
```

A "shared" Pointer Class

- Basic idea
 - shared_ptr class will keep a count of how many copies are alive
 - Constructors/copies increment this count
 - shared_ptr destructor simply decrements this count
 - If count is 0, delete the object

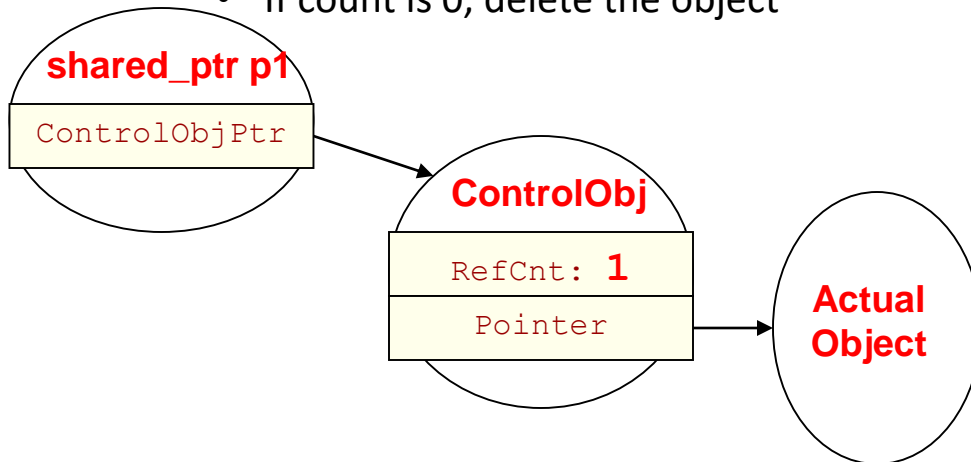

```
int main()
{
    shared_ptr<Obj> p1(new Obj);
    doit(p1);
    return 0;
}

void doit(shared_ptr<Obj> p2)
{
    if(...) {
        shared_ptr<Obj> p3 = p2;
    }
}
```

A "shared" Pointer Class

- Basic idea
 - shared_ptr class will keep a count of how many copies are alive
 - shared_ptr destructor simply decrements this count
 - If count is 0, delete the object

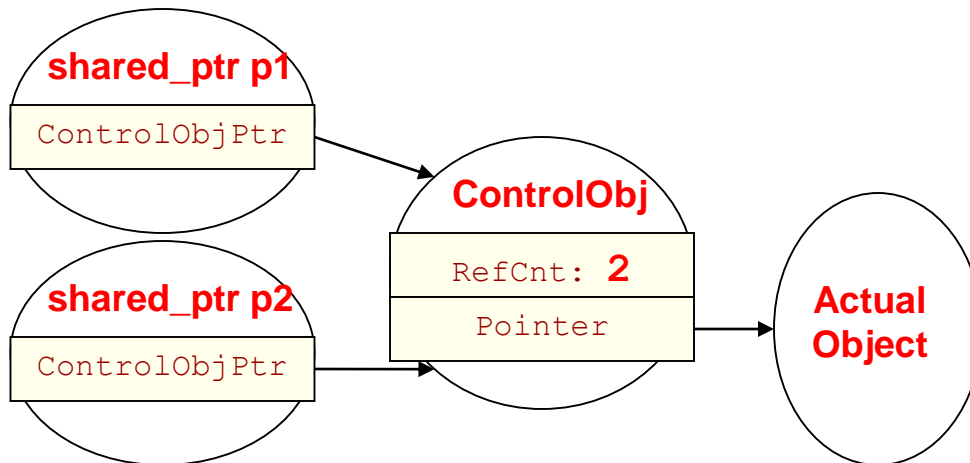

```
int main()
{
    shared_ptr<Obj> p1(new Obj);
    doit(p1);
    return 0;
}

void doit(shared_ptr<Obj> p2)
{
    if(...) {
        shared_ptr<Obj> p3 = p2;
    }
}
```

A "shared" Pointer Class

- Basic idea
 - shared_ptr class will keep a count of how many copies are alive
 - shared_ptr destructor simply decrements this count
 - If count is 0, delete the object

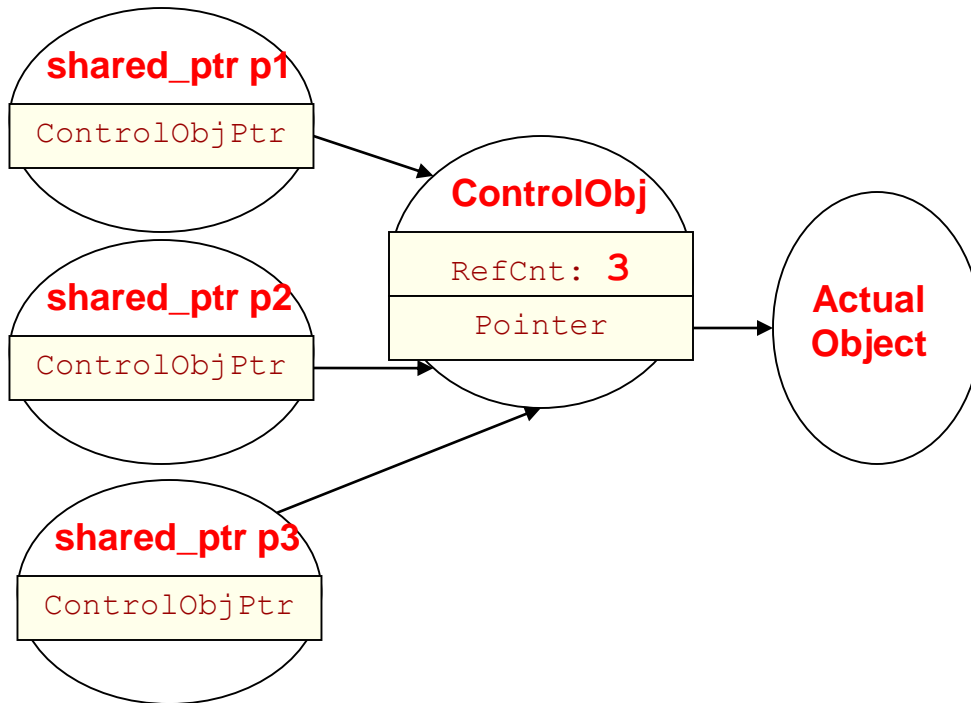

```
int main()
{
    shared_ptr<Obj> p1(new Obj);
    doit(p1);
    return 0;
}

void doit(shared_ptr<Obj> p2)
{
    if(...) {
        shared_ptr<Obj> p3 = p2;
    }
}
```

A "shared" Pointer Class

- Basic idea
 - shared_ptr class will keep a count of how many copies are alive
 - shared_ptr destructor simply decrements this count
 - If count is 0, delete the object

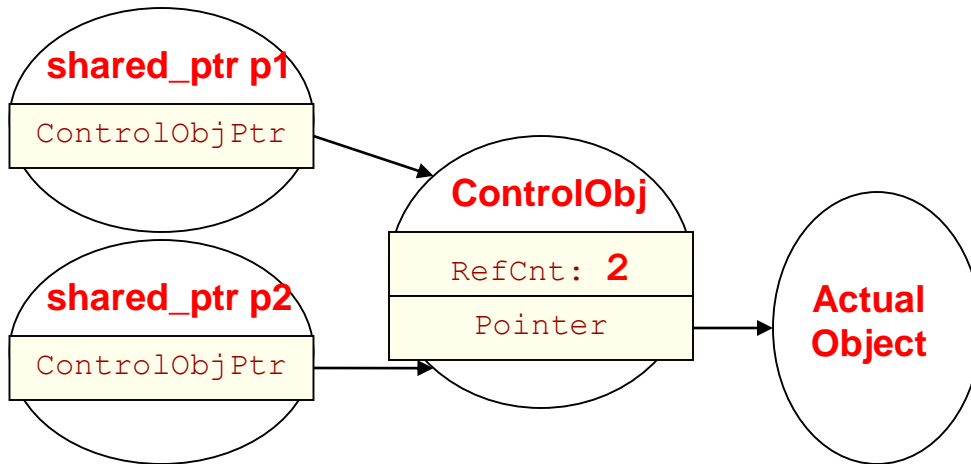

```
int main()
{
    shared_ptr<Obj> p1(new Obj);
    doit(p1);
    return 0;
}

void doit(shared_ptr<Obj> p2)
{
    if(...) {
        shared_ptr<Obj> p3 = p2;

    } // p3 dies
}
```

A "shared" Pointer Class

- Basic idea
 - shared_ptr class will keep a count of how many copies are alive
 - shared_ptr destructor simply decrements this count
 - If count is 0, delete the object

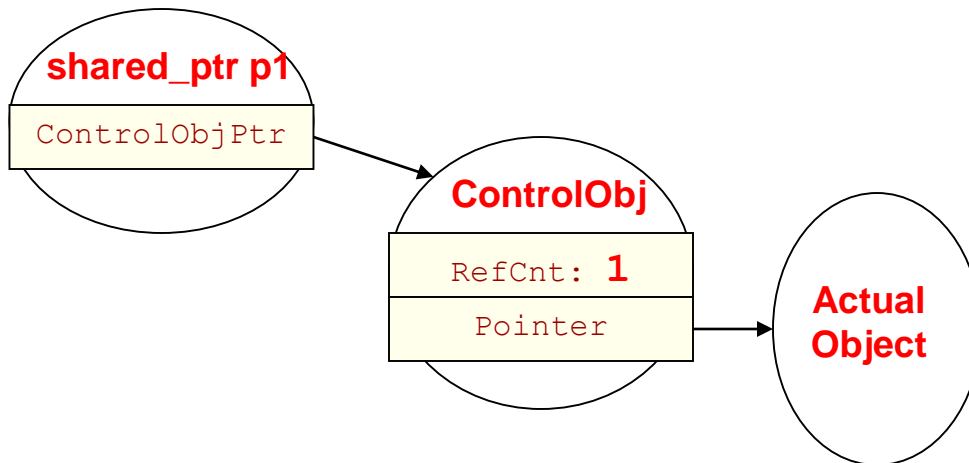

```
int main()
{
    shared_ptr<Obj> p1(new Obj);
    doit(p1);
    return 0;
}

void doit(shared_ptr<Obj> p2)
{
    if(...) {
        shared_ptr<Obj> p3 = p2;
    } // p3 dies
} // p2 dies
```

A "shared" Pointer Class

- Basic idea
 - shared_ptr class will keep a count of how many copies are alive
 - shared_ptr destructor simply decrements this count
 - If count is 0, delete the object

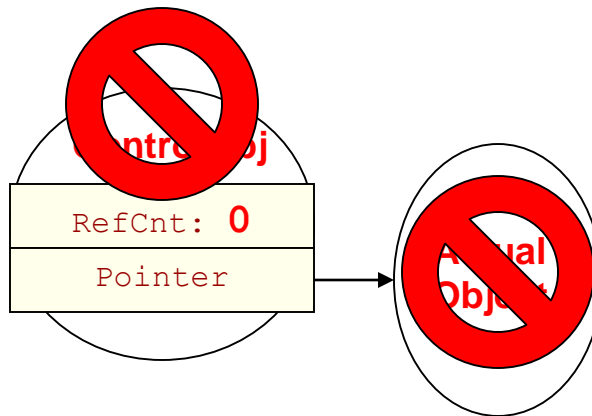

```
int main()
{
    shared_ptr<Obj> p1(new Obj);
    doit(p1);
    return 0;
} // p1 dies

void doit(shared_ptr<Obj> p2)
{
    if(...){
        shared_ptr<Obj> p3 = p2;

    } // p3 dies
} // p2 dies
```

C++ shared_ptr

- C++ std::shared_ptr / boost::shared_ptr
 - Boost is a best-in-class C++ library of code you can download and use with all kinds of useful classes
- Can only be used to point at dynamically allocated data (since it is going to call delete on the pointer when the reference count reaches 0)
- Compile in g++ using '-std=c++11' since this class is part of the new standard library version

```
#include <memory>
#include "obj.h"
using namespace std;

shared_ptr<Obj> f1()
{
    shared_ptr<Obj> ptr(new Obj);
    // ...
    cout << "In F1\n" << *ptr << endl;
    return ptr;
}

int main()
{
    shared_ptr<Obj> p2 = f1();
    cout << "Back in main\n" << *p2;
    cout << endl;
    return 0;
}
```

\$ g++ -std=c++11 shared_ptr1.cpp obj.cpp

C++ shared_ptr

- Using shared_ptr's you can put pointers into container objects (vectors, maps, etc) and not have to worry about iterating through and deleting them
- When myvec goes out of scope, it deallocates what it is storing (shared_ptr's), but that causes the shared_ptr destructor to automatically delete the Objs
- Think about your project homeworks...this might be (have been) nice

```
#include <memory>
#include <vector>
#include "obj.h"
using namespace std;

int main()
{
    vector<shared_ptr<Obj> > myvec;

    shared_ptr<Obj> p1(new Obj);
    myvec.push_back( p1 );

    shared_ptr<Obj> p2(new Obj);
    myvec.push_back( p2 );

    return 0;
    // myvec goes out of scope...
}
```

```
$ g++ -std=c++11 shared_ptr1.cpp obj.cpp
```

shared_ptr vs. unique_ptr

- Both will perform automatic deallocation
- Unique_ptr only allows one pointer to the object at a time
 - Copy constructor and assignment operator are hidden as private functions
 - Object is deleted when pointer goes out of scope
 - Does allow "move" operation
 - If interested read more about this on your own
 - C++11 defines "move" constructors (not just copy constructors) and "rvalue references" etc.
- Shared_ptr allow any number of copies of the pointer
 - Object is deleted when last pointer copy goes out of scope
- Note: Many languages like python, Java, C#, etc. all use this idea of reference counting and automatic deallocation (aka garbage collection) to remove the burden of memory management from the programmer

References

- http://www.umich.edu/~eecs381/handouts/C++11_smart_ptrs.pdf
- <http://stackoverflow.com/questions/3476938/example-to-use-shared-ptr>

ITERATORS

Iteration

- Consider how you iterate over all the elements in a list
 - Use a for loop and get() or operator[]
- For an array list this is fine since each call to get() is $O(1)$
- For a linked list, calling get(i) requires taking i steps through the linked list
 - 0th call = 0 steps
 - 1st call = 1 step
 - 2nd call = 2 steps
 - $0+1+2+\dots+n-2+n-1 = O(n^2)$
- You are repeating the work of walking the list...

```
ArrayList<int> mylist;  
...  
for(int i=0; i < mylist.size(); ++i)  
{  
    cout << mylist.get(i) << endl;  
}
```

```
LinkedList<int> mylist;  
...  
for(int i=0; i < mylist.size(); ++i)  
{  
    cout << mylist.get(i) << endl;  
}
```

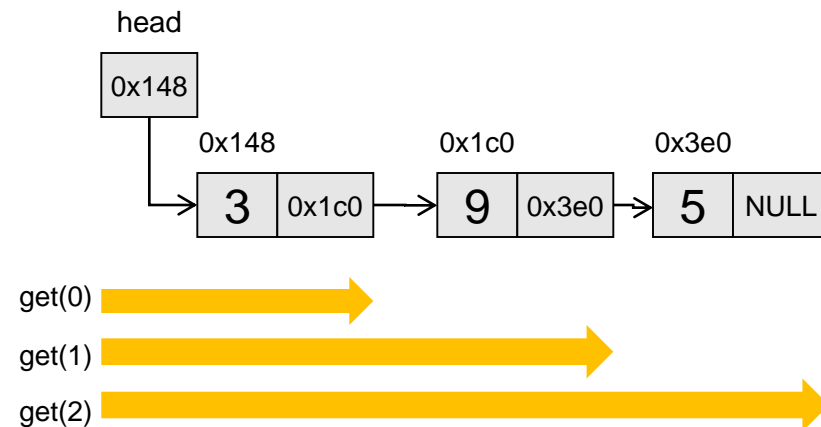

Iteration: A Better Approach

- Solution: Don't use `get(i)`
- Use an **iterator**
 - Stores internal state variable (i.e. another pointer) that remembers where you are and allows taking steps efficiently
- Iterator tracks the internal location of each successive item
- Iterators provide the semantics of a pointer (they look, smell, and act like a pointer to the values in the list)
- Assume
 - `Mylist.begin()` returns an "iterator" to the beginning itme
 - `Mylist.end()` returns an iterator "one-beyond" the last item
 - `++it` (preferrer) or `it++` moves iterator on to the next value

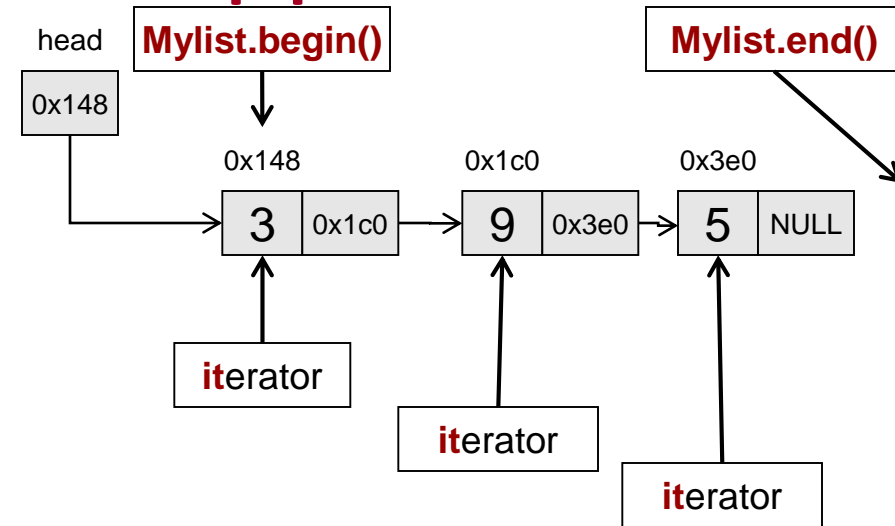

```

LinkedList<int> mylist;
...
iterator it = mylist.begin()
for(it = mylist.begin();
    it != mylist.end();
    ++it)
{
    cout << *it << endl;
}
    
```

Why Iterators

- Can be more efficient
 - Keep internal state variable for where you are in your iteration process so you do NOT have to traverse (re-walk) the whole list every time you want the next value
- Hides the underlying implementation details from the user
 - User doesn't have to know whether its an array or linked list behind the scene to know how to move to the next value
 - To take a step with a pointer in array: `++ptr`
 - To take a step with a pointer in a linked list: `ptr = ptr->next`
 - For some of the data structures like a BST the underlying structure is more complex and to go to the next node in a BST is not a trivial task

More operator overloading...

DEFINING ITERATORS

A "Dumb" Pointer Class

- **Operator***
 - Should return reference (T&) to item pointed at
- **Operator->**
 - Should return a pointer (T*) to item be referenced
- **Operator++()**
 - Preincrement
 - Should return reference to itself iterator& (i.e. return *this)
- **Operator++(int)**
 - Postincrement
 - Should return another iterator pointing to current item will updating itself to point at the next
- **Operator== & !=**

```
template <typename T>
class DumbPtr
{ private:
    T* p_;
public:
    DumbPtr(T* p) : p_(p) { }
    T& operator*() { return *p_; }
    T* operator->() { return p_; }
    DumbPtr& operator++() // pre-inc
        { ++p_; return *this; }
    DumbPtr operator++(int) // post-inc
        { DumbPtr x; x.p_ = p_; ++p_; return x; }
    bool operator==(const DumbPtr& rhs);
        { return p_ == rhs.p_; }
    bool operator!=(const DumbPtr& rhs);
        { return p_ != rhs.p_; }
};

int main()
{
    int data[10];
    DumbPtr<int> ptr(data);

    for(int i=0; i < 10; i++){
        cout << *ptr; ++ptr;
    }
}
```

Pre- vs. Post-Increment

- Recall what makes a function signature unique is combination of name AND number/type of parameters
 - `int f1()` and `void f1()` are the same
 - `int f1(int)` and `void f1()` are unique
- When you write: `obj++` or `++obj` the name of the function will be the same: `operator++`
- To differentiate the designers of C++ arbitrarily said, we'll pass a dummy `int` to the `operator++()` for POST-increment
- So the prototypes look like this...
 - Preincrement: `iterator& operator++();`
 - Postincrement: `iterator operator++(int);`
 - Prototype the 'int' argument, but ignore it...never use it...
 - It's just to differentiate pre- from post-increment

Pre- vs. Post-Increment

- Consider an expression like the following (a=1, b=5):
 - $(a++ * b) + (a * ++b)$
 - $1*5 + 2*6$
 - Operator++ has higher precedence than multiply (*), so we do it first but the post increment means it should appear as if the old value of a is used
 - To achieve this, we could have the following kind of code:
 - `a++ => { int x = a; a = a+1; return x; }`
 - Make a copy of a (which we will use to evaluate the current expr.
 - Increment a so its ready to be used the next time
 - Return the copy of a that we made
 - Preincrement is much easier because we can update the value and then just use it
 - `++b => { b = b+1; return b; }`
- Takeaway: Post-increment is "less efficient" because it causes a copy to be made

Exercise

- Add an iterator to the supplied linked list class
 - \$ mkdir iter_ex
 - \$ cd iter_ex
 - \$ wget <http://ee.usc.edu/~redekopp/cs104/iter.tar>
 - \$ tar xvf iter.tar

Building Our First Iterator

- Let's add an iterator to our Linked List class
 - Will be an object/class that holds some data that allows us to get an item in our list and move to the next item
 - How do you iterate over a linked list normally:
 - **Item<T>* temp = head;**
 - **While(temp) temp = temp->next;**
 - So my iterator object really just needs to model (contain) that 'temp' pointer
- Iterator needs following operators:
 - *
 - ->
 - ++
 - == / !=
 - < ??

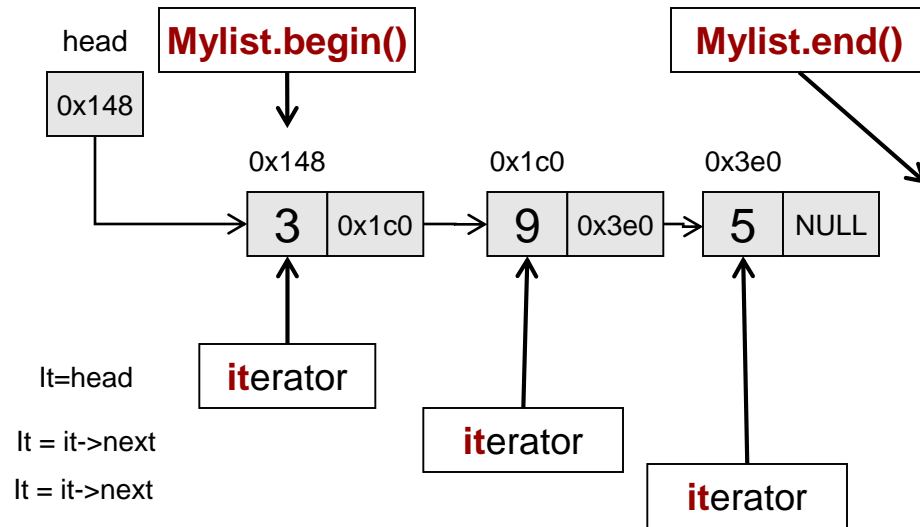

```

template <typename T>
struct Item {
    T val;
    Item<T>* next;
};

template <typename T>
class LList {
public:
    LList(); // Constructor
    ~LList(); // Destructor

private:
    Item<T>* head_;
};
    
```

Implementing Our First Iterator

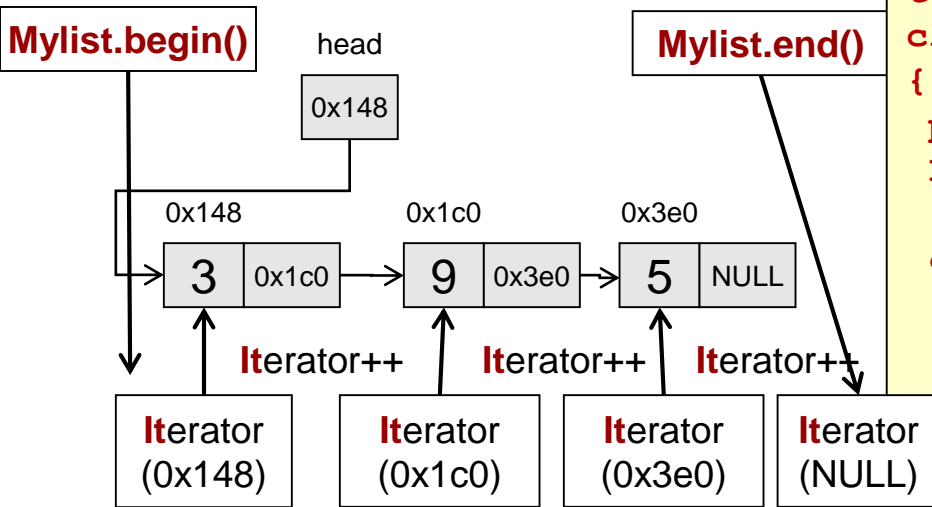

- We store the Item<T> pointer to our current item/node during iteration
- We return the value in the Item when we dereference the iterator
- We update the pointer when we increment the iterator

```

template<typename T>
class LList
{
public:
    LList() { head_ = NULL; }

    class iterator {
    private:
        Item<T>* curr_;
    public:
        iterator& operator++() ;
        iterator operator++(int) ;
        T& operator*() ;
        T* operator->() ;
        bool operator!=(const iterator & other) ;
        bool operator==(const iterator & other) ;
    };

private:
    Item<T>* head_ ;
    int size_ ;
};
    
```

Note: Though class iterator is defined inside LList<T>, it is completely separate and what's private to iterator can't be access by LList<T> and vice versa

Outfitting LList to Support Iterators

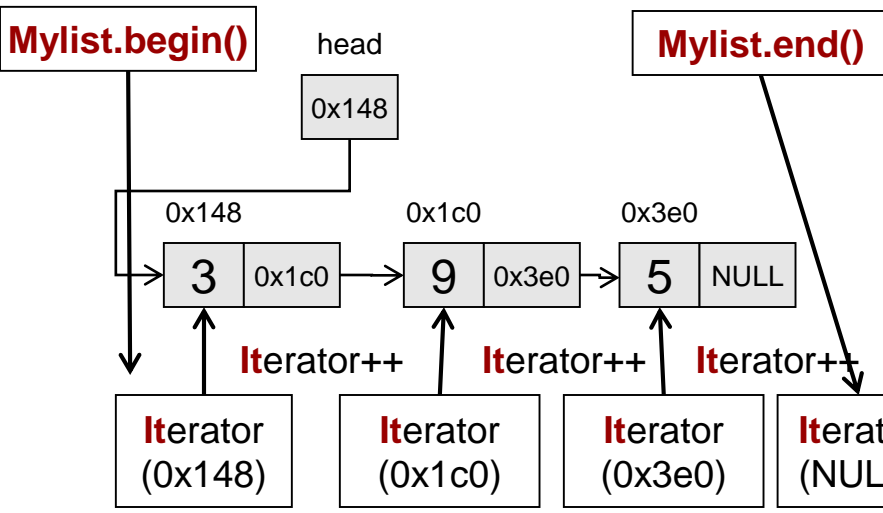

```

template<typename T>
class LList
{
public:
    LList() { head_ = NULL; }

    class iterator {
    private:
        Item<T>* curr_;
    public:
        iterator& operator++() ;
        iterator operator++(int);
        T& operator*();
        T* operator->();
        bool operator!=(const iterator & other);
        bool operator==(const iterator & other);
    };

    iterator begin() { ??? }
    iterator end() { ??? }

private:
    Item<T>* head_;
    int size_;
};
    
```

- begin() and end() should return a new iterator that points to the head or end of the list
- But how should begin() and end() seed the iterator with the correct pointer?

Outfitting LList to Support Iterators

- We could add a public constructor...
- But that's bad form, because then anybody outside the LList could create their own iterator pointing to what they want it to point to...
 - Only LList<T> should create iterators
 - So what to do??

```
template<typename T>
class LList
{
public:
    LList() { head_ = NULL; }

    class iterator {
    private:
        Item<T>* curr_;
    public:
        iterator(Item<T>* init) : curr_(init) {}
        iterator& operator++() ;
        iterator operator++(int);
        T& operator*();
        T* operator->();
        bool operator!=(const iterator & other);
        bool operator==(const iterator & other);
    };

    iterator begin() { ??? }
    iterator end() { ??? }

private:
    Item<T>* head_;
    int size_;
};
```

Friends and Private Constructors

- Let's only have the iterator class grant access to its "trusted" friend: Llist
- Now LList<T> can access iterators private data and member functions
- And we can add a private constructor that only 'iterator' and 'LList<T>' can use
 - This prevents outsiders from creating iterators that point to what they choose
- Now begin() and end can create iterators via the private constructor & return them

```
template<typename T>
class LList
{ public:
    LList() { head_ = NULL; }

    class iterator {
    private:
        Item<T>* curr_;
        iterator(Item<T>* init) : curr_(init) {}
    public:
        friend class LList<T>;
        iterator(Item<T>* init);
        iterator& operator++() ;
        iterator operator++(int);
        T& operator*();
        T* operator->();
        bool operator!=(const iterator & other);
        bool operator==(const iterator & other);
    };
    iterator begin() { iterator it(head_);
                     return it;    }
    iterator end()   { iterator it(NULL);
                     return it;    }

    private:
        Item<T>* head_;
        int size_;
    };
```

Expanding to ArrayLists

- What internal state would an ArrayList iterator store?
- What would begin() stuff the iterator with?
- What would end() stuff the iterator with that would mean "1 beyond the end"?

Const Iterators

- If a `LList<T>` is passed in as a `const` argument, then `begin()` and `end()` will violate the `const`'ness because they aren't declared as `const` member functions
 - `iterator begin() const;`
 - `iterator end() const;`
- While we could change them, it would violate the idea that the `List` will stay `const`, because once someone has an iterator they really CAN change the `List`'s contents
- Solution: Add a second iterator type: `const_iterator`

```
template<typename T>
class LList
{ public:
    LList() { head_ = NULL; }

    class iterator {
    };
    // non-const member functions
    iterator begin() { iterator it(head_);
                    return it;    }
    iterator end()   { iterator it(NULL);
                    return it;    }

private:
    Item<T>* head_;
    int size_;
};

void printMyList(const LList<int>& mylist)
{
    LList<int>::iterator it;
    for(it = mylist.begin(); // compile error
        it != mylist.end();
        ++it)
    { cout << *it << endl; }
}
```

Const Iterators

- The `const_iterator` type should return references and pointers to `const T`'s
- We should add an overloaded `begin()` and `end()` that are `const` member functions and return `const_iterator`s

```
template<typename T>
class LList
{ public:
    LList() { head_ = NULL; }

    class iterator {
        ...
    };
    iterator begin();
    iterator end();

    class const_iterator {
    private:
        Item<T>* curr_;
        const_iterator(Item<T>* init);
    public:
        friend class LList<T>;
        iterator& operator++() ;
        iterator operator++(int);
        T const & operator*();
        T const * operator->();
        bool operator!=(const iterator & other);
        bool operator==(const iterator & other);
    };
    const_iterator begin() const;
    const_iterator end() const;
};
```

Const Iterators

- An updated example

```
void printMyList(const LList<int>& mylist)
{
    LList<int>::const_iterator it;
    for(it = mylist.begin(); // no more error
        it != mylist.end();
        ++it)
    { cout << *it << endl; }
}
```

!= vs <

- It's common idiom to have the loop condition use != over <
- Some iterators don't support '<' comparison
 - Why? Think about what we're comparing with our LList<T>::iterator
 - We are comparing the pointer...Is the address of Item at location 1 guaranteed to be less-than the address of Item at location 2?

```
void printMyList(const LList<int>& mylist)
{
    LList<int>::const_iterator it;

    for(it = mylist.begin(); it != mylist.end(); ++it)
    { cout << *it << endl; }

    for(it = mylist.begin(); it < mylist.end(); ++it)
    { cout << *it << endl; }

}
```

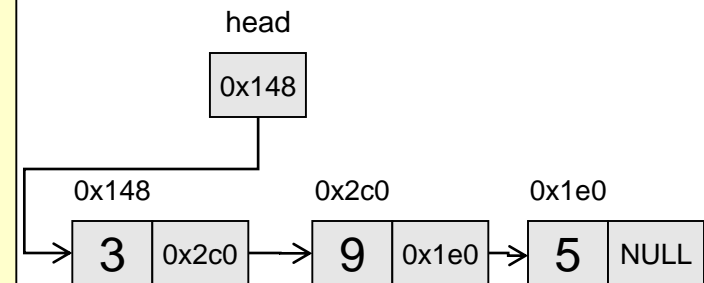

Kinds of Iterators

- This leads us to categorize iterators based on their capabilities (of the underlying data organization)
- Access type
 - Input iterators: Can only READ the value be pointed to
 - Output iterators: Can only WRITE the value be pointed to
- Movement/direction capabilities
 - Forward Iterator: Can only increment (go forward)
 - ++it
 - Bidirectional Iterators: Can go in either direction
 - ++it or --it
 - Random Access Iterators: Can jump beyond just next or previous
 - it + 4 or it - 2
- Which movement/direction capabilities can our `LList<T>::iterator` naturally support

Implicit Type Conversion

- Would the following if condition make sense?
- No! If statements want Boolean variables
- But you've done things like this before
 - Operator >> returns an ifstream&
- So how does ifstream do it?
 - With an "implicit type conversion operator overload"
 - Student::operator bool()
 - Code to specify how to convert a Student to a bool
 - Student::operator int()
 - Code to specify how to convert a Student to an int

```
class Student {
    private:  int id; double gpa;
};
int main()
{
    Student s1;
    if(s1){ cout << "Hi" << endl; }
    return 0;
}
```

```
ifstream ifile(filename);
...
while( ifile >> x )
{ ... }
```

```
class Student {
    private:
        int id; double gpa;
    public:
        operator bool() { return gpa >= 2.0; }
        operator int() { return id; }
};

Student s1;
if(s1)           // calls operator bool() and
    int x = s1; // calls operator int()
```

Iterators With Implicit Conversions

- Can use operator bool() for iterator

```
template<typename T>
class LList
{ public:
    LList() { head_ = NULL; }

    class iterator {
    private:
        Item<T>* curr_;
    public:
        operator bool()
        { return curr_ != NULL; }
    };
};

void printMyList(LList<int>& mylist)
{
    LList<int>::iterator it = mylist.begin();
    while(it){
        cout << *it++ << endl;
    }
}
```

Finishing Up

- Iterators provide a nice abstraction between user and underlying data organization
 - Wait until we use trees and other data organizations
- Due to their saved internal state they can be more efficient than simpler approaches [like `get(i)`]