

EE 457 Unit 6a

Basic Pipelining Techniques

Pipelining Introduction

- Consider a drink bottling plant
 - Filling the bottle = 3 sec.
 - Placing the cap = 3 sec.
 - Labeling = 3 sec.
- Would you want...
 - Machine 1 = Does all three (9 secs.), outputs the bottle, repeats...
 - Machine 2 = Divided into three parts (one for each step) passing bottles between them
- Machine _____ offers ability to _____

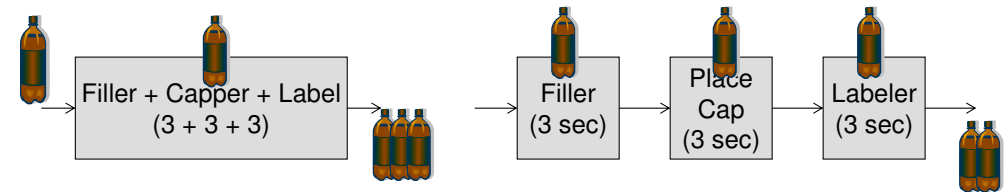

Summing Elements

- Consider adding an array of 4-bit numbers:
 - $Z[i] = A[i] + B[i]$
 - Delay: 10ns Mem. Access (read or write), 10 ns each FA
 - Clock cycle time = _____

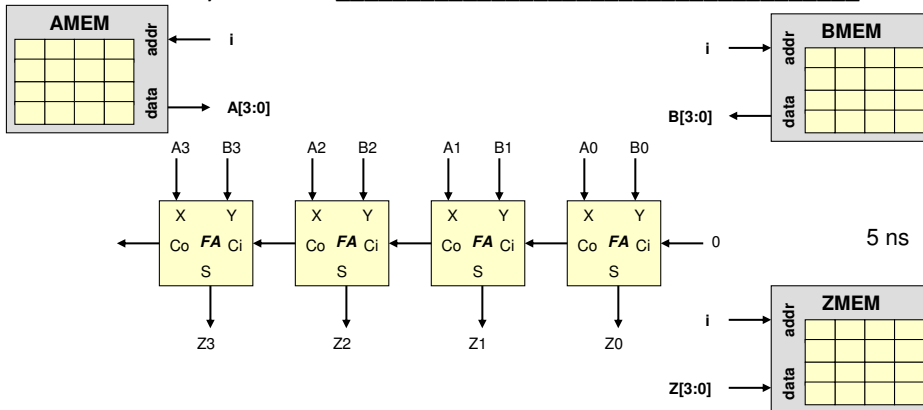

Pipelined Adder

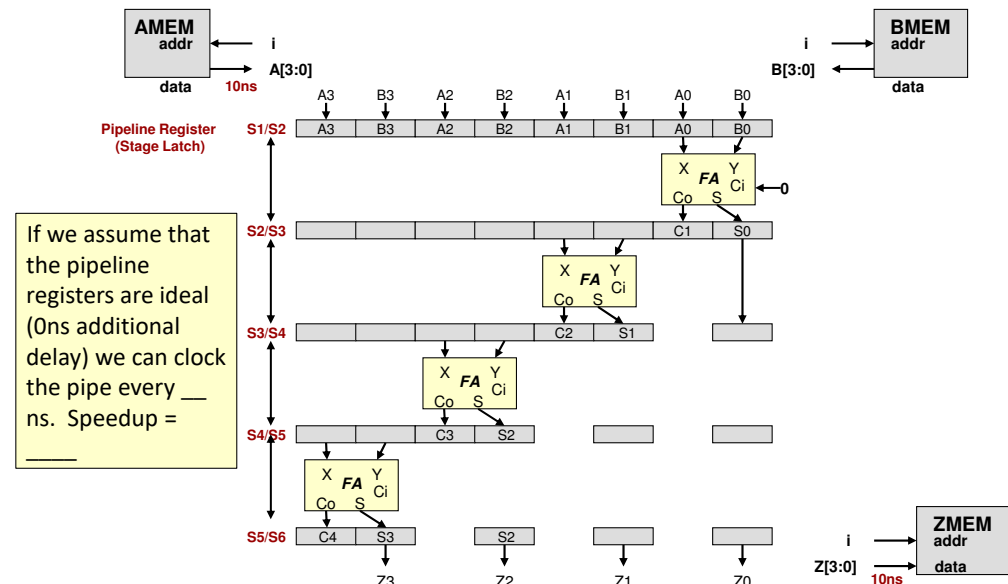

More Pipelining Examples

- Car Assembly Line
- Wash/Dry/Fold
 - Would you buy a combo washer + dryer unit that does both operations in the same tank??
- Freshman/Sophomore/Junior/Senior

Balancing Pipeline Stages

Clock period must equal the **LONGEST** delay from register to register

- Fig. 1: If total logic delay is 20ns => 50MHz
 - Throughput: 1 instruc. / 20 ns
- Fig. 2: Unbalanced stage delays limit the clock speed to the slowest stage (worst case)
 - Throughput: 1 instruc. / 10 ns => 100MHz
- Fig. 3: Better to split into more, balanced stages
 - Throughput: 1 instruc. / 5 ns => 200MHz
- Fig. 4: Are more stages better
 - Ideally: 2x stages => 2x throughput
 - Throughput: 1 instruc. / 2.5 ns => 400MHz
 - **Each register adds extra delay so at some point deeper pipelines don't pay off**

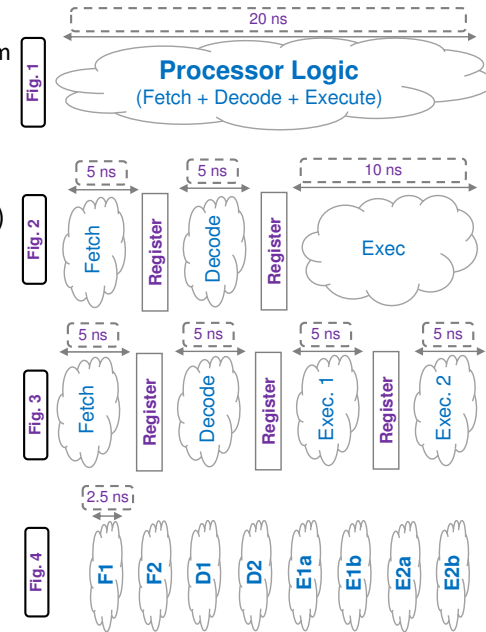

Processors & Pipelines

- Overlaps execution of multiple instructions
- Natural breakdown into stages
 - Fetch, Decode, Execute, Memory, Write-Back
- Fetch an instruction, while decoding another, while executing another

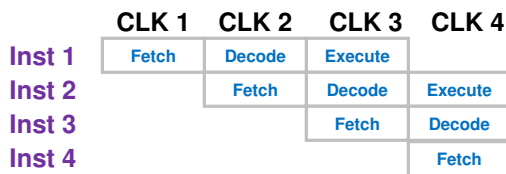

Pipelining (Instruction View)

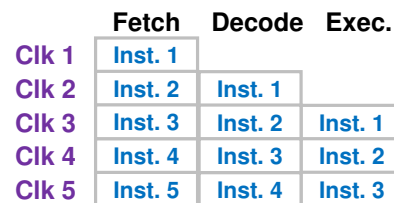

Pipelining (Stage View)

Need for Registers

- Provides separation between combinational functions
 - Without registers, fast signals could “catch-up” to data values in the next operation stage
 - With registers, inputs are “stable”

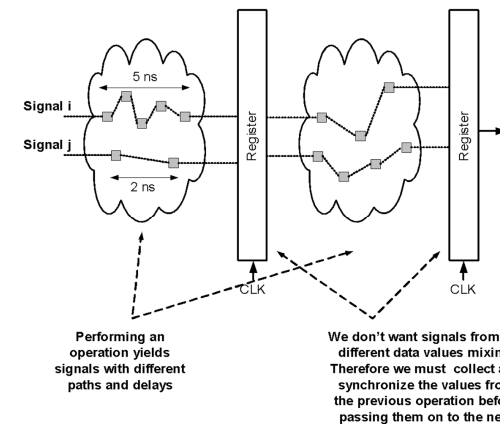

To Register or Latch?

- What should we use for pipeline stages
 - Registers [edge-sensitive] ...or...
 - Latches [level-sensitive]
- Latches may allow data to _____
- Answer: _____

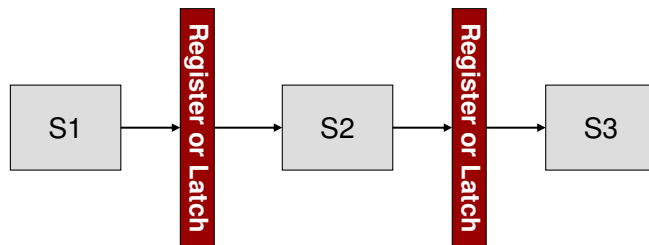

But Can We Latch?

- We can latch if we run the latches on opposite phases of the clock or have a so-called _____
 - Because each latch runs on the opposite phase data can only move one step before being stopped by a latch that is in hold (off) mode
- You may learn more about this in EE577a or EE560 (a technique known as Slack Borrowing & Time Stealing)

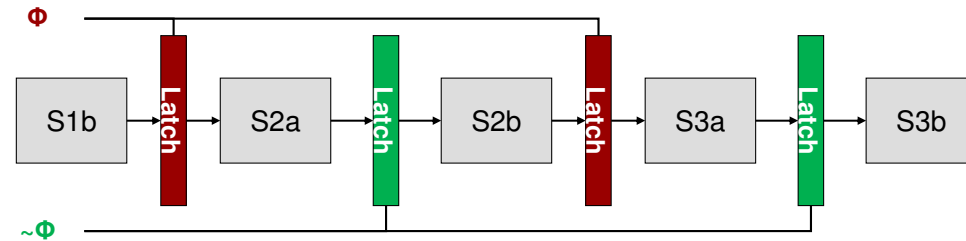

Pipelining Introduction

- Implementation technique that _____ execution of multiple instructions at once
- Improves _____ rather a single-instruction execution latency
- _____ stage determines clock cycle time [e.g. a 30 min. wash cycle but 1 hour dry time means _____ per load]
- Assuming k stages and perfectly balanced stages:
 - Speedup of pipelined vs. nonpipelined =
- A 5-stage pipelined CPU may not realize this speedup 5x b/c...
 - The stages may not be perfectly balanced
 - The overhead of filling up the pipe initially
 - The overhead (setup time and clock-to-Q) delay of the stage registers
 - Inability to keep the pipe full due to branches & data hazards

Single-Cycle CPU Datapath

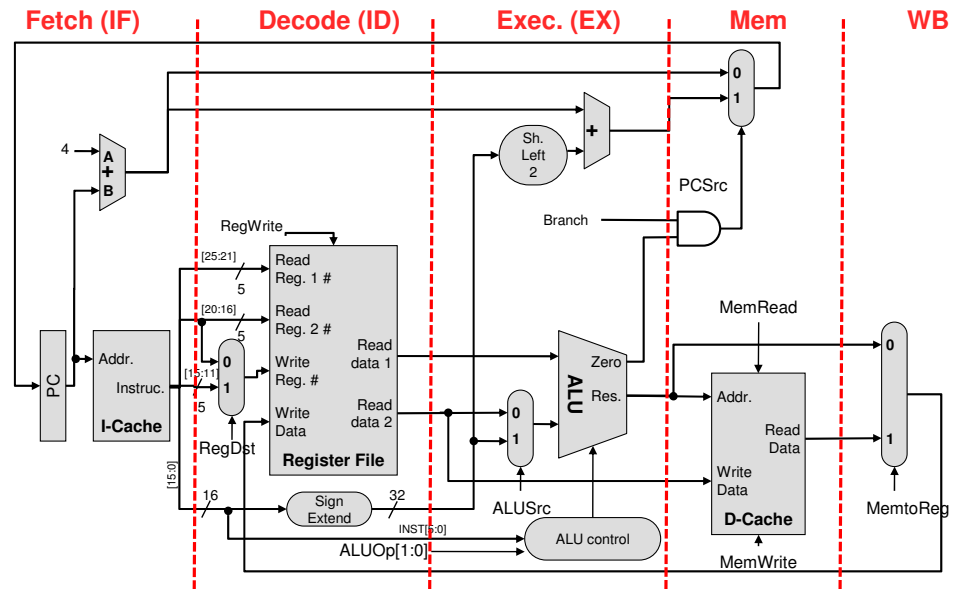

Non-Pipelined Execution

Instruction	Fetch (I-MEM)	Reg. Read	ALU Op.	Data Mem	Reg. Write	Total Time
Load	10 ns	5 ns	10 ns	10 ns	5 ns	40 ns
Store						
R-Type						
Branch						
Jump						

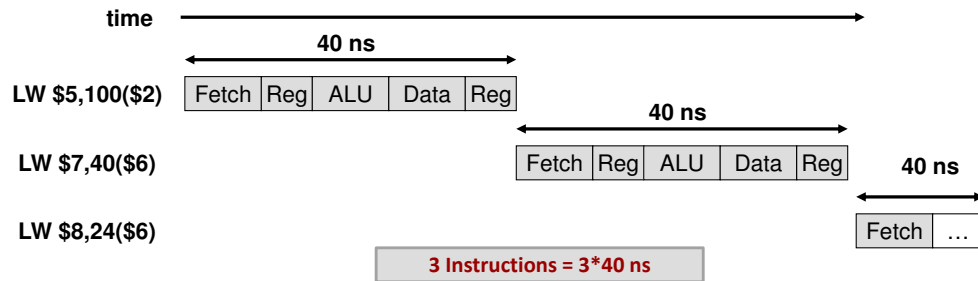

Pipelined Execution

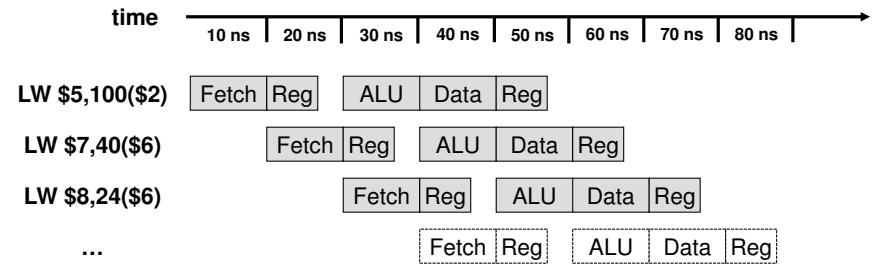

- Notice that even though the register access only takes 5 ns it is allocated a 10 ns slot in the pipeline
- Total time for these 3 pipelined instructions =
 - 70 ns = ___ ns for 1st instruc + ___ for the remaining instructions to complete
- The speedup looks like it is only 120 ns / 70 ns = 1.7x
- But consider 1003 instructions: _____
 - The overhead of filling the pipeline is _____ over steady-state execution when the pipeline is full

Pipelined Timing

- Execute n instructions using a k stage datapath
 - i.e. Multicycle CPU w/ k steps or single cycle CPU w/ clock cycle k times slower
- w/o pipelining: _____
- w/ pipelining: _____
 - ___ cycles for 1st instruc. + ___ cycles for n-1 instrucs.
 - Assumes we keep the pipeline full

	Fetch 10ns	Decode 10ns	Exec. 10ns	Mem. 10ns	WB 10ns
C1	ADD				
C2	SUB	ADD			
C3	LW	SUB	ADD		
C4	SW	LW	SUB	ADD	
C5	AND	SW	LW	SUB	ADD
C6	OR	AND	SW	LW	SUB
C7	XOR	OR	AND	SW	LW
C8		XOR	OR	AND	SW
C9			XOR	OR	AND
C10				XOR	OR
C11					XOR

Pipeline Filling
Pipeline Full
Pipeline Emptying

7 Instrucs. = 11 clocks

Designing the Pipelined Datapath

- To pipeline a datapath in five stages means five instructions will be executing (“in-flight”) during any single clock cycle
- Resources cannot be _____ between stages because there may always be an instruction wanting to use the resource
 - This is known as a _____ HAZARD
 - Each stage needs its own resources
 - The single-cycle CPU datapath also matches this concept of no shared resources
 - We can simply divide the single-cycle CPU into stages

Structural Hazard Example

- **Example structural hazard:** A single SHARED cache (_____) rather than separate instruction & data caches
 - Structural hazard any time an instruction needs to perform a data access (i.e. lw or sw) since we always want to fetch a new instruction each clock cycle

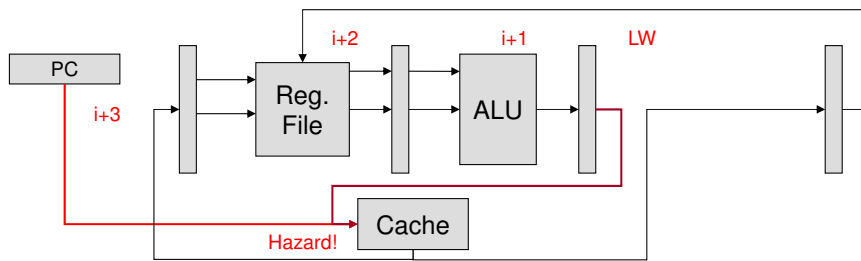

Information Flow in a Pipeline

- Data or control information should flow only in the forward direction in a linear pipeline
 - Non-linear pipelines where information is fed back into a previous stage occurs in more complex pipelines such as floating point dividers
- The CPU pipeline is like a buffet line or cafeteria where people can not try to revisit a a previous serving station without disrupting the smooth flow of the line

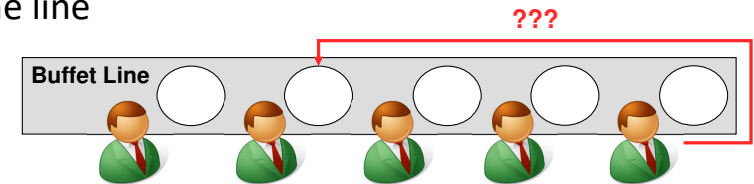

Register File

- Don't we have a non-linear flow when we write a value back to the register file?
 - An instruction in WB is re-using the register file in the ID stage
 - Actually we are utilizing different _____ of the register file
 - ID stage _____ register values
 - WB stage _____ register value
 - Like a buffet line with _____ at one station

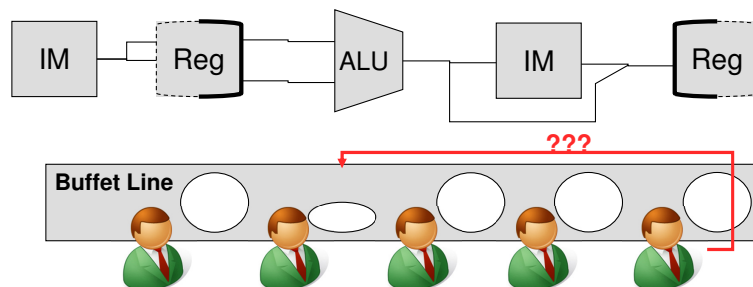

Another Structural Hazard

- **Example structural hazard:** A single SHARED cache (instruction + data) rather than separate instruction & data caches
 - Structural hazard any time an instruction needs to perform a data access (i.e. lw or sw) since we always want to fetch a new instruction each clock cycle

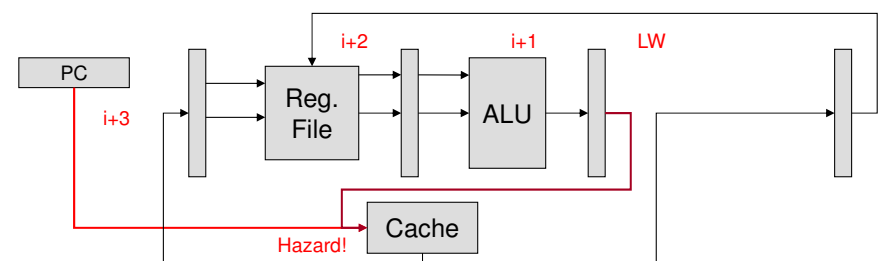

Register File

- Only an issue if WB to same register as being read
- Register file can be designed to do “internal forwarding” where the data being written is immediately _____ out as the _____

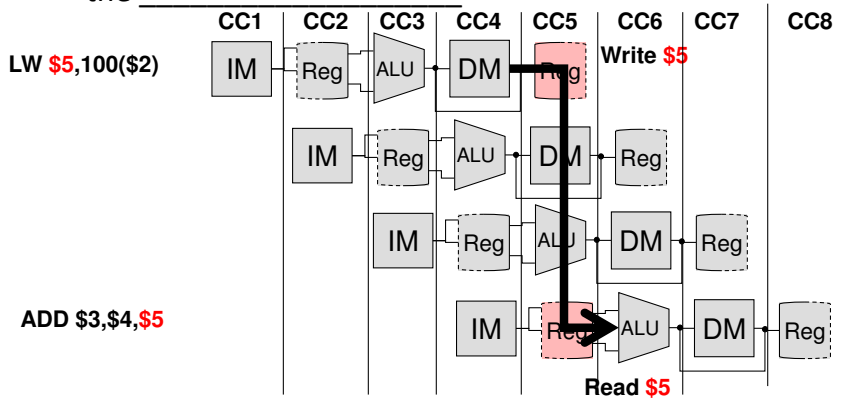

Pipelining the Fetch Phase

- Note that to keep the pipeline full we have to fetch a new instruction every clock cycle
- Thus we have to perform $PC = PC + 4$ every clock cycle
- Thus there shall be no pipelining registers in the datapath responsible for $PC = PC + 4$
- Support for branch/jump warrants a lengthy discussion which we will perform later

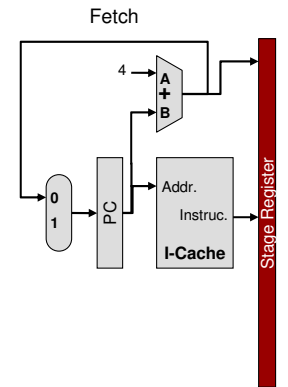

PIPELINE CONTROL

Basic 5 Stage Pipeline

- Compute the size of each pipeline register (find the max. info needed for any instruction in each stage)
- To simplify, just consider LW/SW (Ignore control signals)

LW \$10,40(\$1)	Op = 35	rs=1	rt=10	immed.=40
SW \$15,100(\$2)	Op = 43	rs=2	rt=15	immed.=100

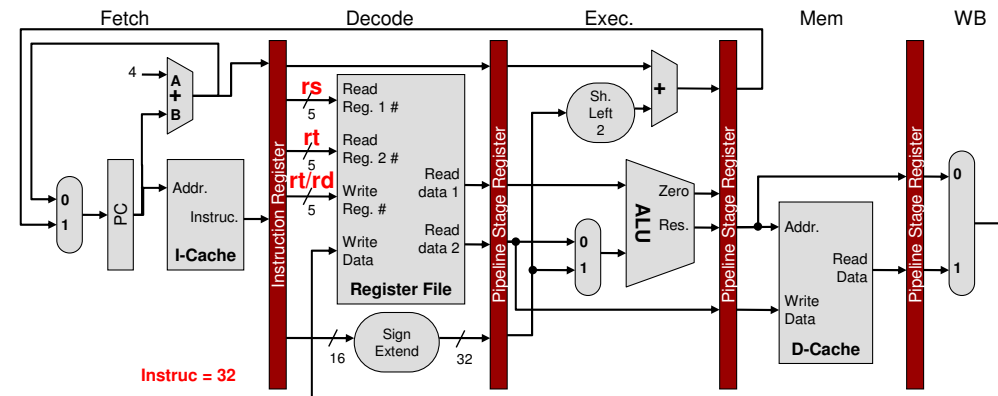

Basic 5 Stage Pipeline

- There is a bug in the load instruction implementation
- Which register is written with the data read from memory?
- We need to preserve the _____ number by carrying it through the pipeline with us
LW \$10,40(\$1)
- In general this is true for all signals needed later in the pipe
SW \$15,100(\$2)

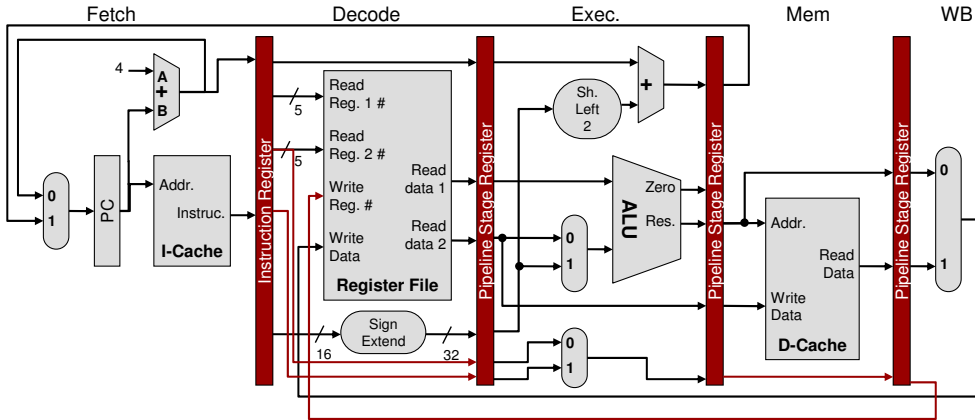

Pipeline Packing List

- Just as when you go on a trip you have to pack everything you need _____ since you cannot come back to your closet, so in pipelines you have to take all the control and data you will need with you down the pipeline until you use it



Pipeline Control Overview

- We will just consider basic (simple) pipeline control and deal with problems related to branch and data hazards later
- It is assumed that the PC and pipeline register update on each clock cycle so no separate write enable signals are needed for these registers

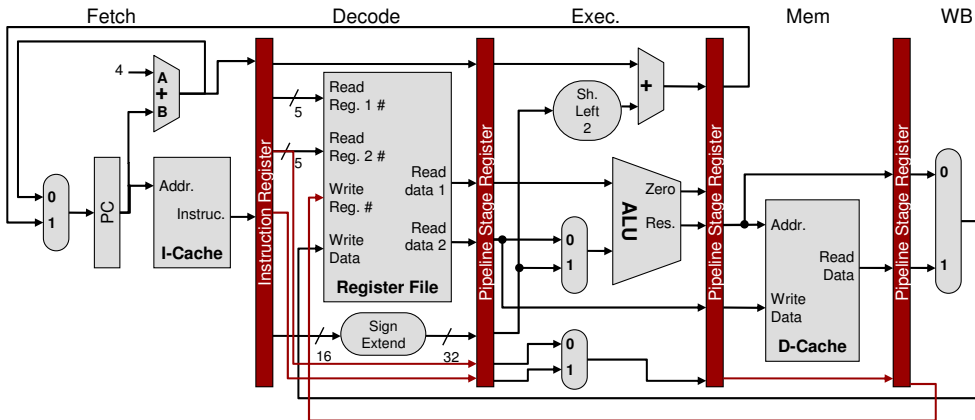

Control Signal Generation

- Recall from the Single-Cycle CPU discussion that there is no state machine control, but a simple translator (combinational logic) to translate the 6-bit opcode into these 9 control signals
- Since the datapaths of the single-cycle and pipelined CPU are essentially the same, so is the control
- The main difference is that the control signals are generated in one clock cycle and used in a subsequent cycle (later pipeline stage)
- We can produce all our signals in the _____ and use the pipeline registers to store and pass them to the _____ stage

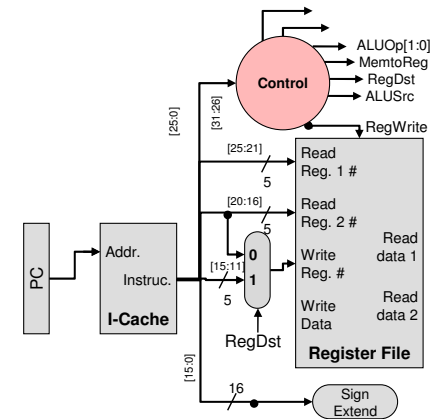

Control Signals per Stage

- How many control signals are needed in each stage

Instruction	Reg Dst	ALU Src	ALU Op[1:0]	Func[5:0]	Branch	Mem Read	Mem Write	Reg Write	Memto-Reg
R-format	1	0	10	...	0	0	0	1	0
LW	0	1	00	X	0	1	0	1	1
SW	X	1	00	X	0	0	1	0	X
Beq	X	0	01	X	0	0	0	0	X

Basic 5 Stage Pipeline

- Control is generated in the decode stage and passed along to consuming stages through stage registers

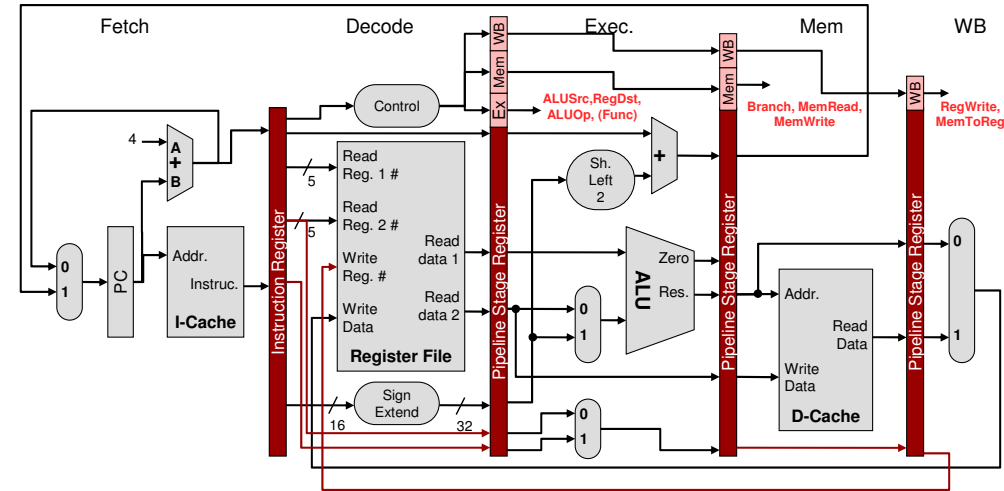

Stage Control

- Instruction Fetch:** The control signals to read instruction memory and to write the PC are always asserted, so there is nothing special to control in this pipeline stage
- ID/RF:** As in the previous stage the same thing happens at every clock cycle so there are no optional control lines to set
- Execution:** The signals to be set are RegDst, ALUOp/Func, and ALUSrc. The signals determine whether the result of the instruction written into the register specified by bits 20-16 (for a load) or 15-11 for an R-format), specify the ALU operation, and determine whether the second operand of the ALU will be a register or a sign-extended immediate
- Memory Stage:** The control lines set in this stage are Branch, MemRead, and MemWrite. These signals are set for the BEQ, LW, and SW instructions respectively
- WriteBack:** the two control lines are RegWrite, which writes the chosen register, and MemToReg, which decides between the ALU result or memory value as the write data

Exercise:

- On copies of this sheet, show this sequence executing on the pipeline:
 - LW \$10,\$0(\$1)
 - SUB \$11,\$2,\$3
 - AND \$12,\$4,\$5
 - OR \$13,\$6,\$7
 - ADD \$14,\$8,\$9

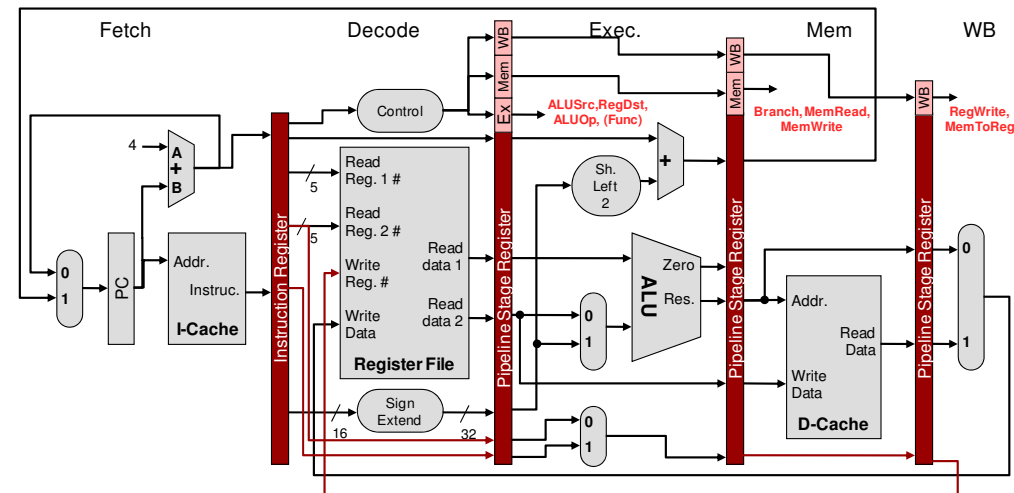

Review

- Although an instruction can begin at each clock cycle, an individual instruction still takes five clock cycles
- Note that it takes four clock cycle before the five-stage pipeline is operating at full efficiency
- Register write-back is controlled by the WB stage even though the register file is located in the ID stage; the correct write register ID is carried down the pipeline with the instruction data
- When a stage is inactive, the values of the control lines are deasserted (shown as 0's) to prevent anything harmful from occurring
- No state machine is needed; sequencing of the control signals follows simply from the pipeline itself (i.e. control signals are produced initially but delayed by the stage registers until the correct stage / clock cycle for application of that signal)

ADDITIONAL REFERENCE

LW \$t1,4(\$s0): Fetch

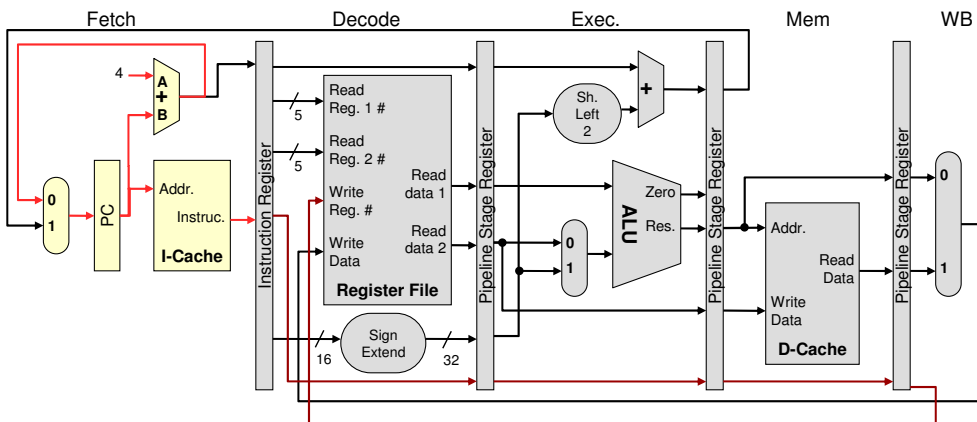

Fetch LW and increment PC

LW \$t1,4(\$s0): Decode

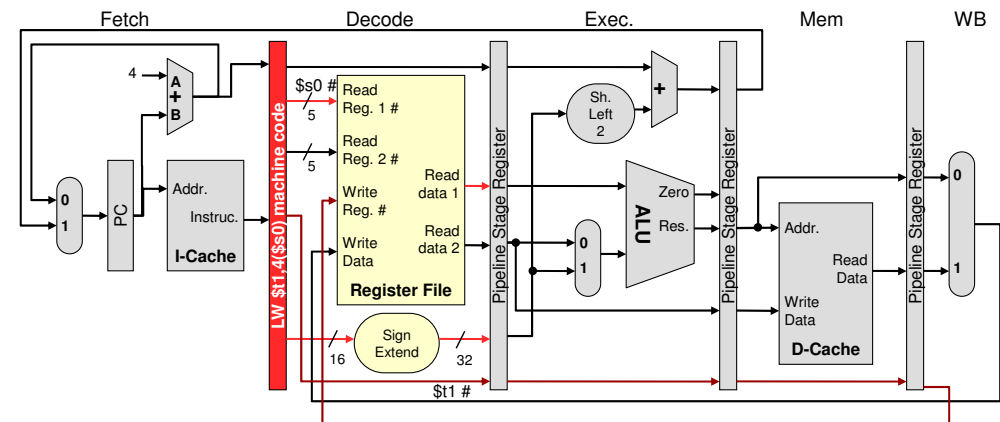

Decode instruction and fetch operands

LW \$t1,4(\$s0): Execute

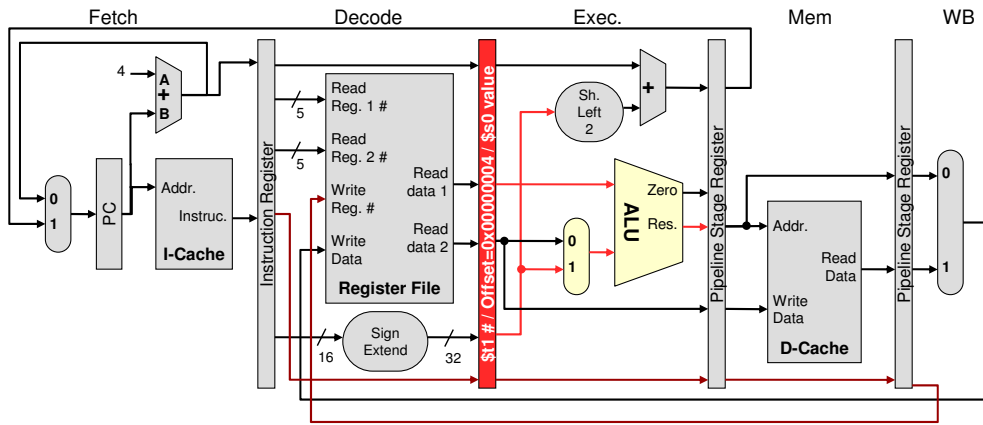

Add offset 4 to \$s0 value

LW \$t1,4(\$s0): Memory

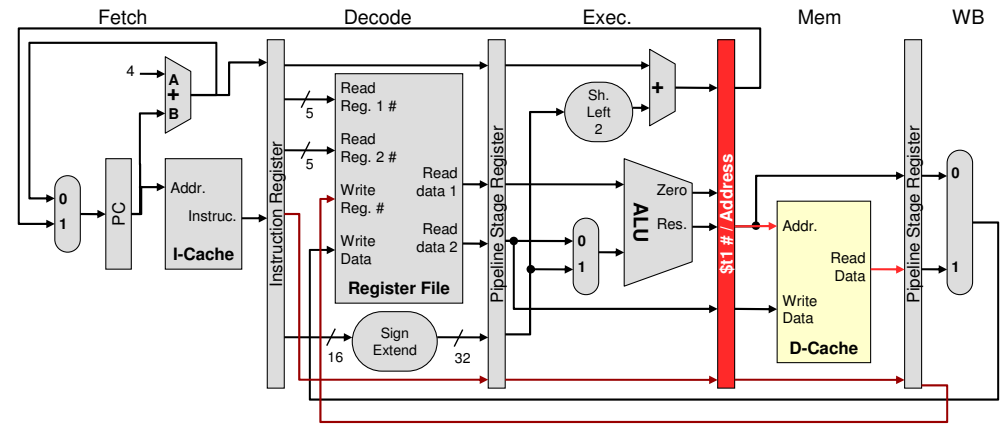

Read word from memory

LW \$t1,4(\$s0): Writeback

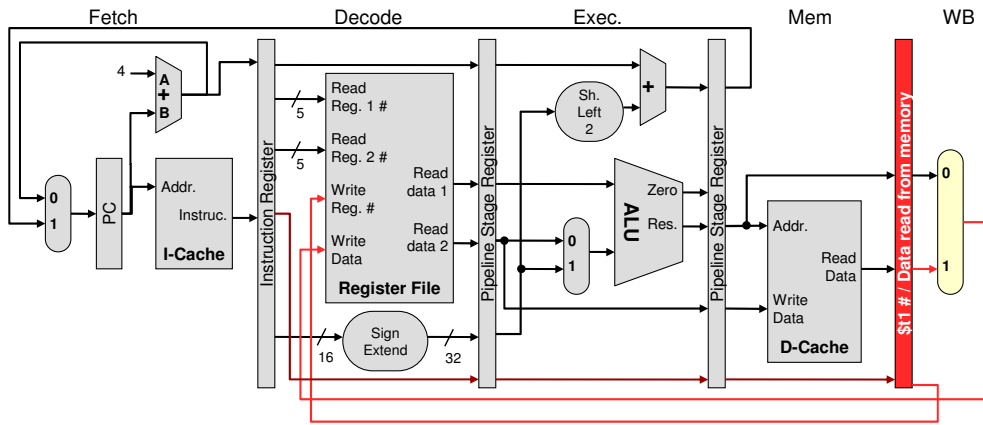

Write word to \$t1

LW \$t1,4(\$s0)

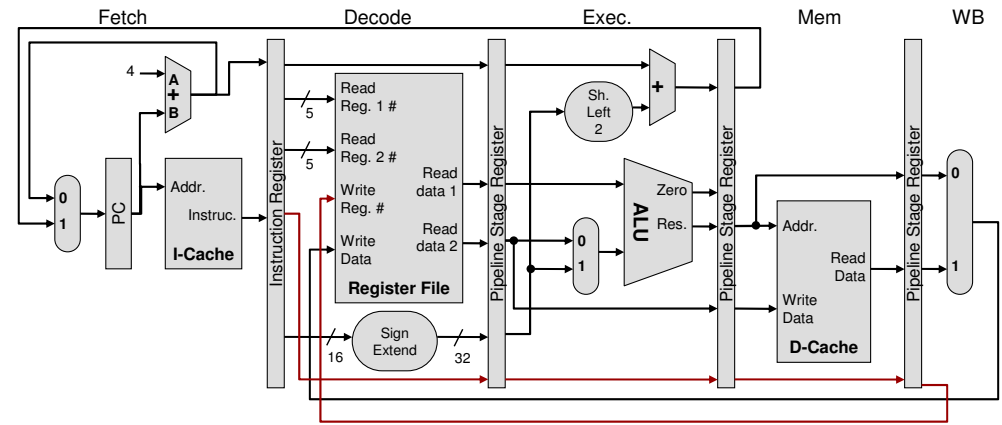

Fetch LW

Decode instruction and fetch operands

Add offset 4 to \$s0

Read word from memory

Write word to \$t1

ADD \$t4,\$t5,\$t6: Fetch

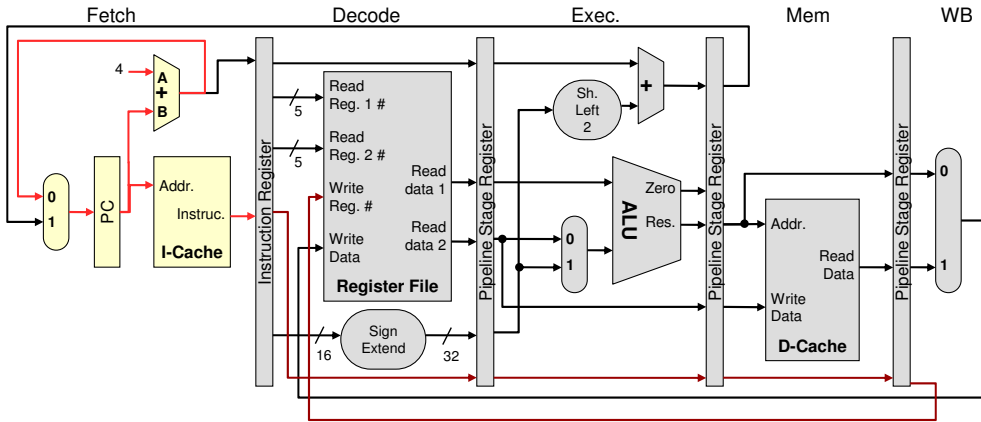

Fetch ADD and increment PC

ADD \$t4,\$t5,\$t6: Decode

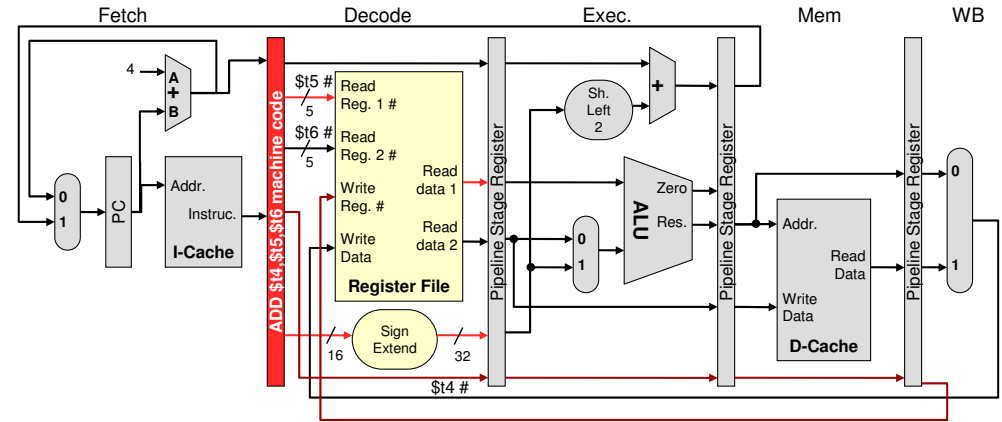

Decode instruction and fetch operands

ADD \$t4,\$t5,\$t6: Execute

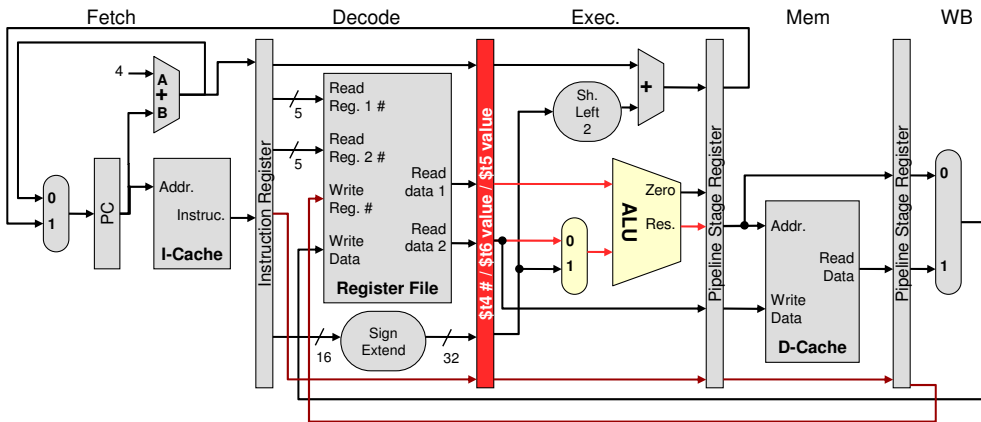

Add \$t5 + \$t6

ADD \$t4,\$t5,\$t6: Memory

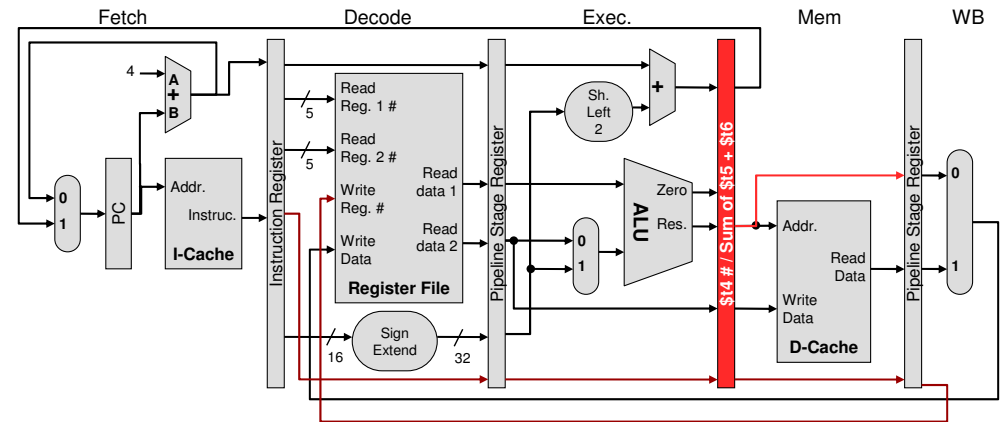

Just pass sum through

ADD \$t4,\$t5,\$t6: Writeback

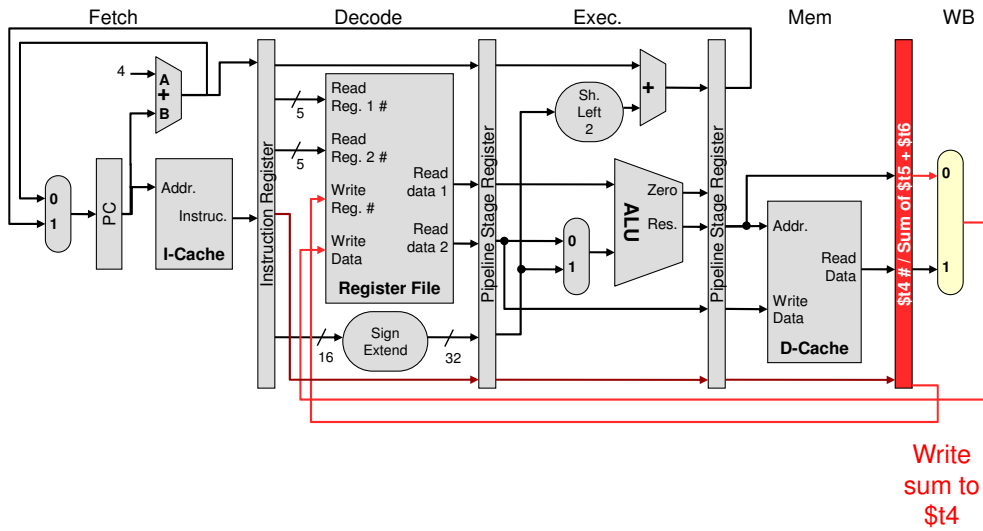

ADD \$t4,\$t5,\$t6

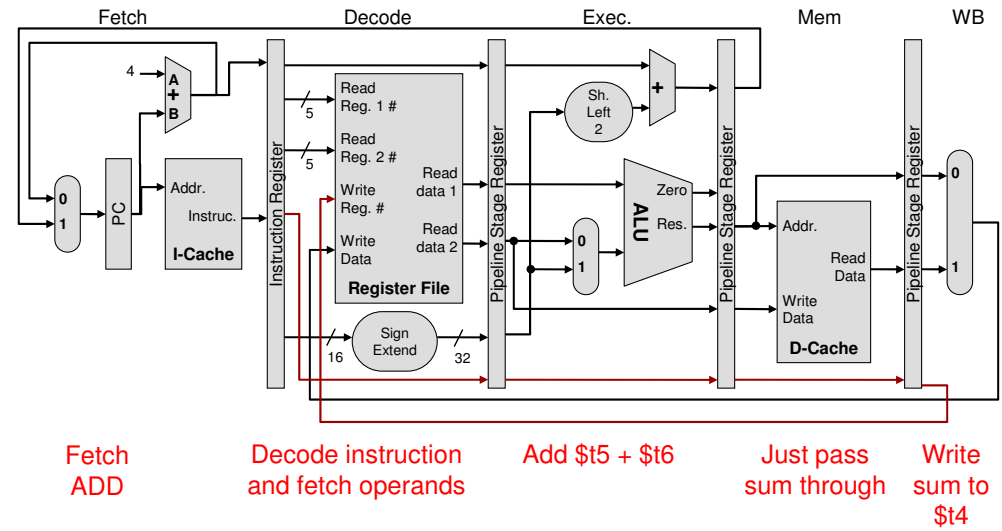

OLD PIPELINING

Basic 5 Stage Pipeline

- Control is generated in the decode stage and passed along to consuming stages through stage registers

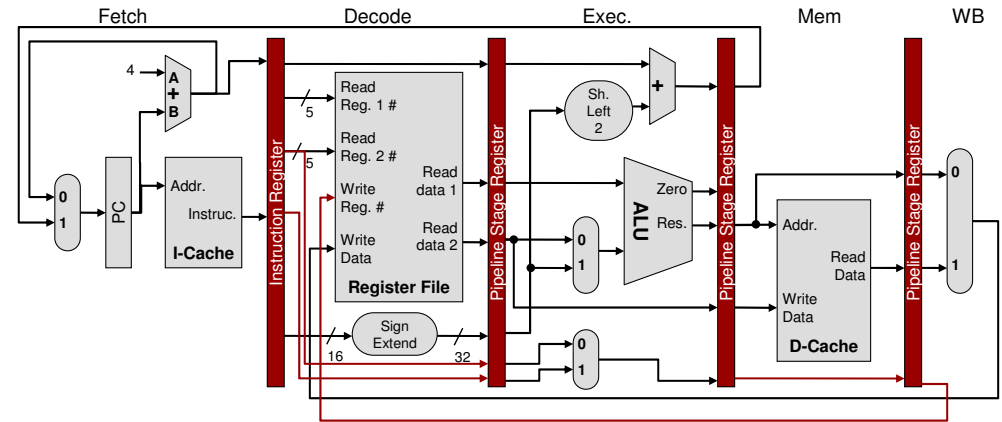

Basic 5 Stage Pipeline

- Control is generated in the decode stage and passed along to consuming stages through stage registers

